

AMP WIRE RANGE	E13288 Listed
8 AWG SOLID OR STRANDED	8 AWG STRANDED
LR7189 Certified	MILITARY P/N AND CLASS
8 AWG SOLID OR STRANDED	NOT APPLICABLE

STAMP AMP 8* APPROX AS SHOWN

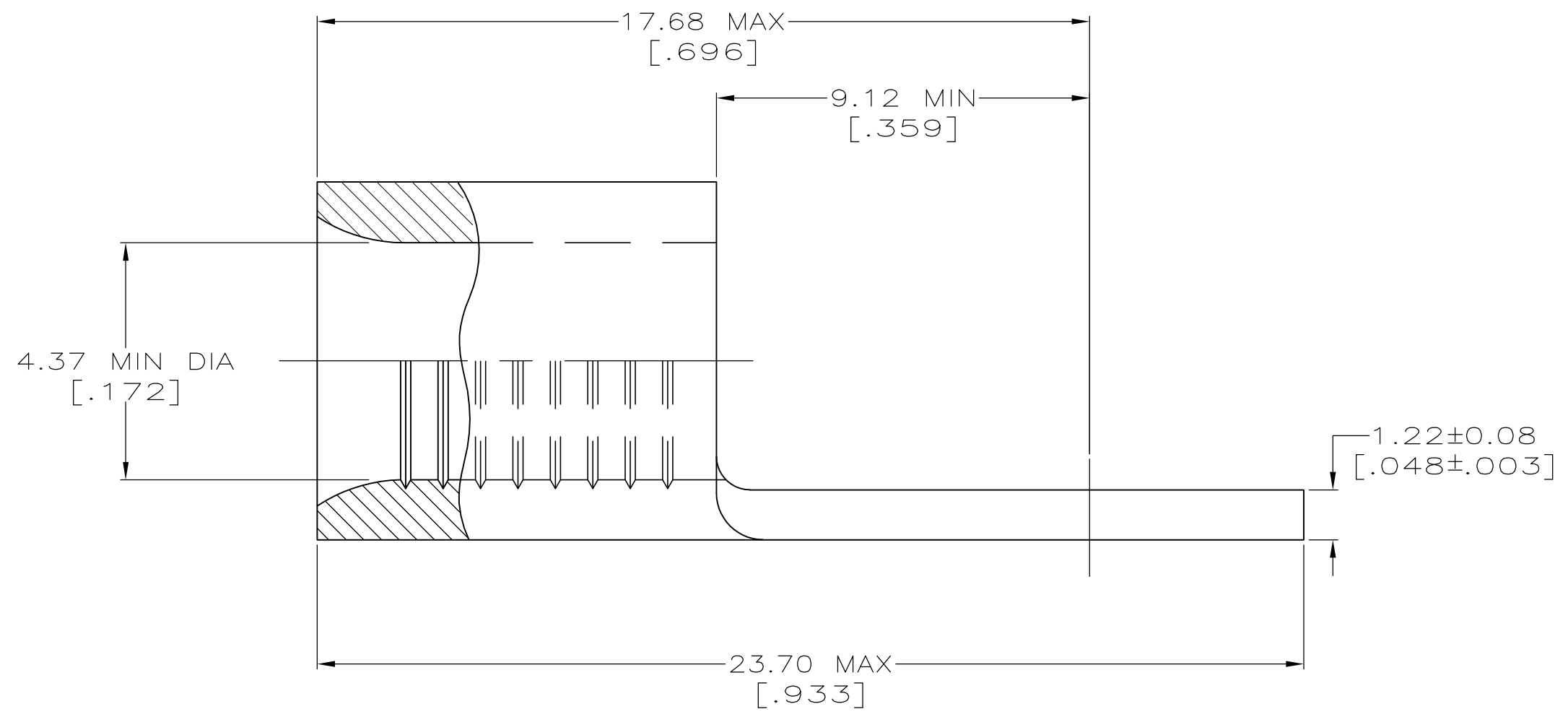

50	TIN PLATE 0.00254[.000100] MIN THK PER MIL-T-10727	LOOSE PIECE BOX 33460	8-33460-2
----	UNPLATED	LOOSE PIECE	2-33460-4
1000	TIN PLATE 0.00254[.000100] MIN THK PER MIL-T-10727	33460 TAPE MOUNTED ON 30.48[1.200] CENTERS	2-33460-3
1500	TIN PLATE 0.00254[.000100] MIN THK PER MIL-T-10727	33460 TAPE MOUNTED ON 15.24[.600] CENTERS	2-33460-2
----	TIN PLATE 0.00254[.000100] MIN THK PER MIL-T-10727	LOOSE PIECE	33460
QUANTITY	FINISH	PACKAGE TYPE	PART NO

AMP INCORPORATED CUSTOMER SERVICE SYSTEMS		MAX RECOMMENDED OPERATING TEMPERATURE: 170° C MAX
FOR ADDITIONAL PRODUCT INFORMATION OR COPIES OF DRAWINGS AND TECHNICAL DOCUMENTS	PRODUCT INFORMATION CENTER 1-800-522-6752	VOLTAGE RATING: NOT APPLICABLE
FOR APPLICATION TOOLING INFORMATION	TOOLING ASSISTANCE CENTER 1-800-722-1111	WIRE CROSS SECTIONAL AREA RANGE: 6.64-10.5mm ² [13,100-20,800] CIR MILS SOLID OR STRANDED
FOR ORDER ENTRY	1-800-526-5142	THIS DRAWING IS A CONTROLLED DOCUMENT FOR AMP INCORPORATED. IT IS SUBJECT TO CHANGE AND THE CONTROLLING ENGINEERING ORGANIZATION SHOULD BE CONTACTED FOR THE LATEST REVISION.

THIS DRAWING IS A CONTROLLED DOCUMENT.		DWN TA BRINKMAN 3-24-93	TE Connectivity	
DIMENSIONS: MM [INCHES]		CHK DA PATTERSON 3-24-93	NAME DE MILLER	
TOLERANCES UNLESS OTHERWISE SPECIFIED:		APVD DE MILLER 3-24-93	PRODUCT SPEC	
0 PLC ± -		APPLICATION SPEC		
1 PLC ± -		WEIGHT		
2 PLC ± -		A2 00779 G-33460		
3 PLC ± -		CUSTOMER DRAWING		
4 PLC ± -		SCALE 8:1 SHEET 1 OF 1 REV S1		
ANGLES ± ± -		RESTRICTED TO		
FINISH		SEE TABLE		
MATERIAL COPPER PER ASTM B-152 ANNEALED		DRAWING NO		