

# MAX3948

## 11.3Gbps, Low-Power, DC-Coupled Laser Driver

### General Description

The MAX3948 is a 3.3V, multirate, low-power laser diode driver designed for Ethernet, Fibre Channel, and SONET transmission systems at data rates up to 11.3Gbps. This device is optimized to drive a differential transmitter optical subassembly (TOSA) with a 25Ω flex circuit. The unique design of the output stage enables DC-coupling to unmatched TOSAs, thereby lowering transmitter power consumption by more than 100mW.

The MAX3948 receives differential AC-coupled signals with on-chip termination. It can deliver laser modulation currents of up to 85mA at an edge speed of 26ps (20% to 80%) into a 5Ω external differential load. The device is designed to have a high-bandwidth differential signal path with on-chip back termination resistors integrated into its outputs. An input equalization block can be activated to compensate for SFP+/QSFP+ host connector losses. The integrated DC circuit provides programmable laser DC currents up to 61mA. Both the laser DC current generator and the laser modulator can be disabled from a single pin.

The device offers one dedicated pin (VSEL) to program up to four channel addresses for multichannel applications.

The use of a 3-wire digital interface reduces the pin count while permitting adjustment of input equalization, polarity, output deemphasis, and modulation and DC currents without the need for external components. The MAX3948 is available in a 3mm x 3mm, 16-pin TQFN package, and is specified for the -40°C to +95°C extended temperature range.

### Applications

40GBASE-LR4 QSFP+ Optical Transceivers  
10GBASE-LR SFP+ Optical Transceivers  
10GBASE-LRM SFP+ Optical Transceivers  
OC192-SR SFP+ SDH/SONET Transceivers

### Benefits and Features

- ◆ **Lowest Power Consumption**
  - ◇ 168mW Typical IC Power Dissipation at 3.3V (LD<sub>MOD</sub> = 40mA, LD<sub>DC</sub> = 20mA)
  - ◇ 383mW Total Transmitter Power Dissipation at 3.3V Including LD<sub>MOD</sub> = 40mA, LD<sub>DC</sub> = 20mA
  - ◇ Enables < 1W Maximum Total SFP+ Module Power Dissipation
  - ◇ Enables < 2.5W Maximum Total QSFP+ Module Power Dissipation
- ◆ **Saves Board Space**
  - ◇ Small 3mm x 3mm Package
  - ◇ DC-Coupling to the Laser Reduces External Component Count
- ◆ **Flexibility**
  - ◇ Operate Up to Four MAX3948 ICs Over Single 3-Wire Digital Interface
  - ◇ Programmable Modulation Current Up to 85mA (5Ω Load)
  - ◇ Programmable DC Current Up to 61mA (Translates to Up to 100mA Laser Bias Current)
  - ◇ Programmable Input Equalization and Output Deemphasis
- ◆ **Safety**
  - ◇ Supports SFF-8431 SFP+ MSA and SFF-8472 Digital Diagnostic
  - ◇ Integrated Eye Safety Features with Maskable Faults
  - ◇ DC Current Monitor

[Ordering Information](#) appears at end of data sheet.

## 11.3Gbps, Low-Power, DC-Coupled Laser Driver

### ABSOLUTE MAXIMUM RATINGS

$V_{CC}, V_{CCT}$  ..... -0.3V to +4.0V  
 $|V_{CC} - V_{CCT}|$  ..... < 0.5V  
 Voltage Range at TIN+, TIN-, DISABLE, SDA, SCL, CSEL, VSEL, FAULT, and BMON.....-0.3V to  $V_{CC}$   
 Voltage Range at VOUT and TOUTC ..... 0.4V to ( $V_{CCT} - 0.4V$ )  
 Voltage Range at TOUTA.....( $V_{CCT} - 1.3V$ ) to ( $V_{CCT} + 1.3V$ )  
 Current Range into TIN+ and TIN-..... -20mA to +20mA  
 Current Range into VOUT ..... -2mA to +90mA

Current into TOUTC and TOUTA ..... +150mA  
 Continuous Power Dissipation ( $T_A = +70^\circ\text{C}$ )  
     TQFN (derate 20.8mW/ $^\circ\text{C}$  above  $+70^\circ\text{C}$ )..... 1666.7mW  
 Storage Temperature Range .....  $-55^\circ\text{C}$  to  $+150^\circ\text{C}$   
 Die Attach Temperature .....  $+400^\circ\text{C}$   
 Lead Temperature (soldering, 10s) .....  $+300^\circ\text{C}$   
 Soldering Temperature (reflow) .....  $+260^\circ\text{C}$

Stresses beyond those listed under "Absolute Maximum Ratings" may cause permanent damage to the device. These are stress ratings only, and functional operation of the device at these or any other conditions beyond those indicated in the operational sections of the specifications is not implied. Exposure to absolute maximum rating conditions for extended periods may affect device reliability.

### PACKAGE THERMAL CHARACTERISTICS (Note 1)

TQFN

Junction-to-Ambient Thermal Resistance ( $\theta_{JA}$ ) .....  $48^\circ\text{C/W}$   
 Junction-to-Case Thermal Resistance ( $\theta_{JC}$ ) .....  $10^\circ\text{C/W}$

**Note 1:** Package thermal resistances were obtained using the method described in JEDEC specification JESD51-7, using a four-layer board. For detailed information on package thermal considerations, refer to [www.maximintegrated.com/thermal-tutorial](http://www.maximintegrated.com/thermal-tutorial).

### ELECTRICAL CHARACTERISTICS

( $V_{CC} = V_{CCT} = 2.95\text{V}$  to  $3.63\text{V}$ ,  $T_A = -40^\circ\text{C}$  to  $+95^\circ\text{C}$ ; typical values are at  $V_{CC} = V_{CCT} = 3.3\text{V}$ ,  $T_A = +25^\circ\text{C}$ ,  $LD_{DC} = 20\text{mA}$ ,  $LD_{MOD} = 40\text{mA}$ , and  $14\Omega$  single-ended electrical output load, unless otherwise noted. See [Figure 1](#) for electrical setup.) (Note 2)

| PARAMETER                       | SYMBOL            | CONDITIONS  | MIN  | TYP  | MAX  | UNITS     |
|---------------------------------|-------------------|---|------|------|------|-----------|
| <b>POWER SUPPLY</b>             |                   |   |      |      |      |           |
| Power-Supply Current            | $I_{CC}$          | Excludes output current through the external pullup inductors (Note 3)  |      | 51   | 62   | mA        |
| Power-Supply Voltage            | $V_{CCT}, V_{CC}$ |   | 2.95 |      | 3.63 | V         |
| <b>POWER-ON RESET</b>           |                   |   |      |      |      |           |
| $V_{CC}$ for Enable High        |                   |   |      | 2.55 | 2.75 | V         |
| $V_{CC}$ for Enable Low         |                   |   | 2.3  | 2.45 |      | V         |
| <b>DATA INPUT SPECIFICATION</b> |                   |   |      |      |      |           |
| Input Data Rate                 |                   |   | 1    | 10.3 | 11.3 | Gbps      |
| Differential Input Voltage      | $V_{IN}$          | Launch amplitude into FR4 transmission line $\leq 12\text{in}$ ,<br>SET_TXEQ[1:0] = 01b,<br>SET_TXEQ[1:0] = 11b | 0.2  |      | 0.8  | $V_{P-P}$ |
|                                 |                   | SET_TXEQ[1:0] = 01b,<br>SET_TXEQ[1:0] = 11b,<br>outside of optimized range                                      | 0.15 |      | 1.0  |           |
|                                 |                   | SET_TXEQ[1:0] = 00b   | 0.15 |      | 1.0  |           |
| Common-Mode Input Voltage       | $V_{CM}$          |   |      | 2.15 |      | V         |
| Differential Input Resistance   | $R_{IN}$          |   | 75   | 100  | 125  | $\Omega$  |

## 11.3Gbps, Low-Power, DC-Coupled Laser Driver

### ELECTRICAL CHARACTERISTICS (continued)

( $V_{CC} = V_{CCT} = 2.95V$  to  $3.63V$ ,  $T_A = -40^{\circ}C$  to  $+95^{\circ}C$ ; typical values are at  $V_{CC} = V_{CCT} = 3.3V$ ,  $T_A = +25^{\circ}C$ ,  $I_{DC} = 20mA$ ,  $I_{MOD} = 40mA$ , and  $14\Omega$  single-ended electrical output load, unless otherwise noted. See [Figure 1](#) for electrical setup.) (Note 2)

| PARAMETER   | SYMBOL        | CONDITIONS  | MIN           | TYP             | MAX           | UNITS      |
|---|---------------|---|---------------|-----------------|---------------|------------|
| Differential Input S-Parameters<br>(Note 4)             | SCD11         | $0.1GHz \leq f \leq 11.3GHz$  |               | -40             |               | dB         |
|   | SDD11         | $f \leq 4.1GHz$   |               | -19             |               |            |
|   |               | $4.1GHz \leq f \leq 11.3GHz$  |               | -16             |               |            |
|   | SCC11         | $1GHz \leq f \leq 11.3GHz$ , $Z_{CM\_SOURCE} = 25\Omega$                    |               | -15             |               |            |
| <b>DC CURRENT GENERATOR (Note 5, Figure 3)</b>          |               |   |               |                 |               |            |
| Maximum DC DAC Current                                  | $I_{DCMAX}$   | Current into VOUT pin   | 50            | 61              |               | mA         |
| Minimum DC DAC Current                                  | $I_{DCMIN}$   | Current into VOUT pin   |               |                 | 2.5           | mA         |
| DC-Off Current  | $I_{DC-OFF}$  |   |               |                 | 0.1           | mA         |
| DC DAC LSB Size   |               |   |               | 116             |               | $\mu A$    |
| DC DAC Integral Nonlinearity                            | INL           | $2.5mA \leq I_{DC} \leq 50mA$   |               | $\pm 0.5$       |               | %FS        |
| DC DAC Differential Nonlinearity                        | DNL           | Guaranteed monotonic at 8-bit resolution, SET_IDC[8:1]                      |               | $\pm 0.5$       |               | LSB        |
| DC Current DAC Stability                                |               | $2.5mA \leq I_{DC} \leq 50mA$ , $V_{VOUT} = V_{CCT} - 1.5V$<br>(Notes 6, 7) |               | 1               | 4             | %          |
| DC Compliance Voltage at VOUT                           |               |   | $V_{CCT} - 2$ | $V_{CCT} - 1.5$ | $V_{CCT} - 1$ | V          |
| BMON Current Gain                                       | $G_{BMON}$    | $G_{BMON} = I_{BMON}/I_{DC}$ , external resistor to GND defines voltage     | 15            | 16.7            | 20            | mA/A       |
| BMON Current Gain Stability                             |               | $2.5mA \leq I_{DC} \leq 50mA$ , $V_{VOUT} = V_{CCT} - 1.5V$<br>(Notes 6, 7) |               | 1.5             | 5             | %          |
| Compliance Voltage at BMON                              |               |   | 0             |                 | 1.8           | V          |
| <b>LASER MODULATOR (Note 8)</b>                         |               |   |               |                 |               |            |
| Maximum Laser Modulation Current                        | $I_{MODMAX}$  | Current into TOUTC pin, $5\Omega$ laser load, 6.25% deemphasis              | 85            |                 |               | $mA_{P-P}$ |
| Minimum Laser Modulation Current                        | $I_{MODMIN}$  | Current into TOUTC pin, $5\Omega$ laser load, 6.25% deemphasis              |               |                 | 10            | $mA_{P-P}$ |
| Modulation-Off Laser Current                            | $I_{MOD-OFF}$ | Current into TOUTC pin  |               |                 | 0.1           | mA         |
| Modulation DAC Full-Scale Current                       | $I_{MOD-FS}$  |   | 99.7          | 130             |               | mA         |
| Modulation DAC LSB Size                                 |               |   |               | 247             |               | $\mu A$    |
| Modulation DAC Integral Nonlinearity                    | INL           |   |               | $\pm 1$         |               | %FS        |
| Modulation DAC Differential Nonlinearity                | DNL           | Guaranteed monotonic at 8-bit resolution, SET_IMOD[8:1]                     |               | $\pm 0.5$       |               | LSB        |
| TOUTA and TOUTC Instantaneous Output Compliance Voltage | $V_{TOUTA}$   | With external inductive pullup to $V_{CCT}$                                 | $V_{CCT} - 1$ | $V_{CCT} + 1$   |               | V          |
|   | $V_{TOUTC}$   | With external inductive pullup to VOUT                                      | 0.6           | $V_{CCT} - 1$   |               |            |

## 11.3Gbps, Low-Power, DC-Coupled Laser Driver

### ELECTRICAL CHARACTERISTICS (continued)

( $V_{CC} = V_{CCT} = 2.95V$  to  $3.63V$ ,  $T_A = -40^\circ C$  to  $+95^\circ C$ ; typical values are at  $V_{CC} = V_{CCT} = 3.3V$ ,  $T_A = +25^\circ C$ ,  $LD_{DC} = 20mA$ ,  $LD_{MOD} = 40mA$ , and  $14\Omega$  single-ended electrical output load, unless otherwise noted. See [Figure 1](#) for electrical setup.) (Note 2)

| PARAMETER                             | SYMBOL     | CONDITIONS  | MIN                 | TYP  | MAX                 | UNITS    |
|---------------------------------------|------------|---|---------------------|------|---------------------|----------|
| Modulation Output Termination         | $R_{OUT}$  |   | 19                  | 25   | 31                  | $\Omega$ |
| Modulation Current DAC Stability      |            | $10mA \leq LD_{MOD} \leq 85mA$ ,<br>$V_{VOUT} = V_{CCT} - 1.5V$ (Notes 6, 7)  |                     | 1.5  | 4                   | %        |
| Modulation Current Rise/Fall Time     | $t_R, t_F$ | 20% to 80%, $10mA \leq LD_{MOD} \leq 85mA$<br>(Note 6)  |                     | 26   | 36                  | ps       |
| Deterministic Jitter (Note 6)         | DJ         | $10mA \leq LD_{MOD} \leq 85mA$ , 8.5Gbps with<br>K28.5 pattern  |                     | 4    |                     | psp-p    |
|                                       |            | $10mA \leq LD_{MOD} \leq 85mA$ , 10.3125Gbps<br>(Note 9)  |                     | 6    | 12                  |          |
|                                       |            | $10mA \leq LD_{MOD} \leq 85mA$ , 11.3Gbps<br>(Note 9)   |                     | 8    | 13                  |          |
| Random Jitter                         | RJ         | $10mA \leq LD_{MOD} \leq 85mA$ (Note 6)   |                     | 0.19 | 0.55                | psRMS    |
| Differential S-Parameters<br>(Note 4) | SCC22      | $0.1GHz \leq f \leq 4.1GHz$ , $Z_{CM\_SOURCE} =$<br>$12.5\Omega$  |                     | -10  |                     | dB       |
|                                       |            | $4.1GHz < f \leq 11.3GHz$ , $Z_{CM\_SOURCE} =$<br>$12.5\Omega$  |                     | -6   |                     |          |
|                                       | SDD22      | $0.1GHz < f \leq 11.3GHz$ , $Z_{DIFF\_SOURCE} =$<br>$50\Omega$  |                     | -13  |                     |          |
| <b>SAFETY FEATURES</b>                |            |   |                     |      |                     |          |
| Threshold Voltage at VOUT             |            | Fault never occurs for $V_{VOUT} \geq V_{CCT} - 2V$ ,<br>fault always occurs for $V_{VOUT} < V_{CCT} -$<br>$2.8V$ , referenced to $V_{CCT}$     | $V_{CCT} -$<br>2.8  |      | $V_{CCT}$<br>- 2    | V        |
|                                       |            | Fault never occurs for $V_{VOUT} \geq 1.7V$ , fault<br>always occurs for $V_{VOUT} < 1.35V$ ,<br>referenced to GND,<br>$SET\_IMOD[8:6] = 111b$  | 1.35                |      | 1.7                 |          |
|                                       |            | Fault never occurs for $V_{VOUT} \geq 0.57V$ , fault<br>always occurs for $V_{VOUT} < 0.43V$ ,<br>referenced to GND,<br>$SET\_IMOD[8:6] = 000b$ | 0.43                |      | 0.57                |          |
| Threshold Voltage at TOUTC            |            | Fault never occurs for $V_{TOUTC} \geq 0.48V$ ,<br>fault always occurs for $V_{TOUTC} < 0.35V$  | 0.35                |      | 0.48                | V        |
| Threshold Voltage at TOUTA            |            | Fault never occurs for $V_{TOUTA} \geq V_{CCT} -$<br>$1.45V$ , fault always occurs for $V_{TOUTA} <$<br>$V_{CCT} - 1.88V$                       | $V_{CCT} -$<br>1.88 |      | $V_{CCT} -$<br>1.45 | V        |
| Threshold Voltage at $V_{CCT}$        |            | Fault never occurs for $V_{CCT} \geq V_{CC} - 0.15V$ ,<br>fault always occurs for $V_{CCT} < V_{CC} - 0.4V$                                     | $V_{CC} -$<br>0.4   |      | $V_{CC} -$<br>0.15  | V        |

## 11.3Gbps, Low-Power, DC-Coupled Laser Driver

### ELECTRICAL CHARACTERISTICS (continued)

( $V_{CC} = V_{CCT} = 2.95V$  to  $3.63V$ ,  $T_A = -40^{\circ}C$  to  $+95^{\circ}C$ ; typical values are at  $V_{CC} = V_{CCT} = 3.3V$ ,  $T_A = +25^{\circ}C$ ,  $LD_{DC} = 20mA$ ,  $LD_{MOD} = 40mA$ , and  $14\Omega$  single-ended electrical output load, unless otherwise noted. See [Figure 1](#) for electrical setup.) (Note 2)

| PARAMETER  | SYMBOL        | CONDITIONS   | MIN            | TYP | MAX      | UNITS     |
|--|---------------|--|----------------|-----|----------|-----------|
| <b>TIMING REQUIREMENTS (Notes 5, 6, 8)</b>                         |               |  |                |     |          |           |
| Initialization Time  | $t_{INIT}$    | $LD_{DC} = 25mA$ , $LD_{MOD} = 65mA$ , DC and modulation DAC are both H0x00, time from TX_EN = high to $LD_{DC}$ and $LD_{MOD}$ at 90% of steady state |                | 250 |          | ns        |
| DISABLE Assert Time  | $t_{OFF}$     | Time from rising edge of DISABLE input signal to $LD_{DC}$ and $LD_{MOD}$ at 10% of steady state (Note 6)  |                | 25  | 75       | ns        |
| DISABLE Negate Time  | $t_{ON}$      | Time from falling edge of DISABLE to $LD_{DC}$ and $LD_{MOD}$ at 90% of steady state (Note 6)  |                | 250 | 600      | ns        |
| FAULT Reset Time   | $t_{RECOVER}$ | Time from negation of latched fault using DISABLE to $LD_{DC}$ and $LD_{MOD}$ at 90% of steady state   |                | 250 | 600      | ns        |
| FAULT Assert Time  | $t_{FAULT}$   | Time from fault to FAULT = high, $C_{FAULT} \leq 20pF$ , $R_{FAULT} = 4.7k\Omega$  |                | 0.7 | 3        | $\mu s$   |
| DISABLE to Reset Time  |               | Time DISABLE must be held high to reset fault  | 4              |     |          | $\mu s$   |
| <b>DIGITAL I/O SPECIFICATIONS (SDA, SCL, CSEL, FAULT, DISABLE)</b> |               |  |                |     |          |           |
| Input High Voltage   | $V_{IH}$      |  | 1.8            |     | $V_{CC}$ | V         |
| Input Low Voltage  | $V_{IL}$      |  | 0              |     | 0.8      | V         |
| Input Hysteresis   | $V_{HYST}$    |  |                | 80  |          | mV        |
| Input Capacitance  | $C_{IN}$      |  |                |     | 5        | pF        |
| DISABLE Input Resistance   | $R_{PULL}$    | Internal pullup resistor   | 4.7            | 7.5 | 10       | $k\Omega$ |
| Input Leakage Current (DISABLE)                                    | $I_{IH}$      | Input connected to $V_{CC}$  |                |     | 10       | $\mu A$   |
|  | $I_{IL}$      | Input connected to GND   |                | 440 | 775      |           |
| Input Leakage Current (SDA)  | $I_{IH}$      | Input connected to $V_{CC}$  | -2             |     | +2       | $\mu A$   |
|  | $I_{IL}$      | Input connected to GND; internal pullup is $75k\Omega$ typical   | 35             |     | 75       |           |
| Input Leakage Current (SCL, CSEL)                                  | $I_{IH}$      | Input connected to $V_{CC}$ ; internal pulldown is $75k\Omega$ typical   | 35             |     | 75       | $\mu A$   |
|  | $I_{IL}$      | Input connected to GND   | -2             |     | +2       |           |
| Output High Voltage (SDA, FAULT)                                   | $V_{OH}$      | External pullup is ( $4.7k\Omega$ to $10k\Omega$ ) to $V_{CC}$   | $V_{CC} - 0.1$ |     |          | V         |
| Output Low Voltage (SDA, FAULT)                                    | $V_{OL}$      | External pullup is ( $4.7k\Omega$ to $10k\Omega$ ) to $V_{CC}$   |                |     | 0.4      | V         |

## 11.3Gbps, Low-Power, DC-Coupled Laser Driver

### ELECTRICAL CHARACTERISTICS (continued)

( $V_{CC} = V_{CCT} = 2.95V$  to  $3.63V$ ,  $T_A = -40^{\circ}C$  to  $+95^{\circ}C$ ; typical values are at  $V_{CC} = V_{CCT} = 3.3V$ ,  $T_A = +25^{\circ}C$ ,  $LD_{DC} = 20mA$ ,  $LD_{MOD} = 40mA$ , and  $14\Omega$  single-ended electrical output load, unless otherwise noted. See [Figure 1](#) for electrical setup.) (Note 2)

| PARAMETER   | SYMBOL    | CONDITIONS   | MIN               | TYP                 | MAX               | UNITS |
|---|-----------|--|-------------------|---------------------|-------------------|-------|
| <b>3-WIRE DIGITAL INTERFACE TIMING CHARACTERISTICS (Figure 5)</b> |           |  |                   |                     |                   |       |
| SCL Clock Frequency   | $f_{SCL}$ |  |                   | 400                 | 1000              | kHz   |
| SCL Pulse-Width High  | $t_{CH}$  |  | 500               |                     |                   | ns    |
| SCL Pulse-Width Low   | $t_{CL}$  |  | 500               |                     |                   | ns    |
| SDA Setup Time  | $t_{DS}$  |  |                   | 100                 |                   | ns    |
| SDA Hold Time   | $t_{DH}$  |  |                   | 100                 |                   | ns    |
| SCL Rise to SDA Propagation Time                                  | $t_D$     |  |                   | 5                   |                   | ns    |
| CSEL Pulse-Width Low  | $t_{CSW}$ |  | 500               |                     |                   | ns    |
| CSEL Leading Time Before the First SCL Edge                       | $t_L$     |  |                   | 500                 |                   | ns    |
| CSEL Trailing Time After the Last SCL Edge                        | $t_T$     |  |                   | 500                 |                   | ns    |
| SDA, SCL Load   | $C_B$     | Total bus capacitance on one line with $4.7k\Omega$ pullup to $V_{CC}$ |                   |                     | 20                | pF    |
| <b>VSEL FOUR-LEVEL DIGITAL INPUT (Note 10, Table 2)</b>           |           |  |                   |                     |                   |       |
| Input Voltage High  |           | 3-wire address, ADDR[6:5] = 11b  | $5/6V_{CC} + 0.2$ |                     | $V_{CC}$          | V     |
| Input Voltage Mid-High  |           | 3-wire address, ADDR[6:5] = 10b  | $3/6V_{CC} + 0.2$ | $2/3 \times V_{CC}$ | $5/6V_{CC} - 0.2$ | V     |
| Input Voltage Mid-Low   |           | 3-wire address, ADDR[6:5] = 01b  | $1/6V_{CC} + 0.2$ | $1/3 \times V_{CC}$ | $3/6V_{CC} - 0.2$ | V     |
| Input Voltage Low   |           | 3-wire address, ADDR[6:5] = 00b  | 0                 |                     | $1/6V_{CC} - 0.2$ | V     |

**Note 2:** Specifications at  $T_A = -40^{\circ}C$  and  $+95^{\circ}C$  are guaranteed by design and characterization.

**Note 3:**  $V_{OUT}$  is connected to 1.9V.  $T_{OUTA}$  is connected to  $V_{CCT}$  through pullup inductors, and  $T_{OUTC}$  is connected to  $V_{OUT}$  through pullup inductors.

**Note 4:** Measured with Agilent 8720ES + ATN-U112A and series RC ( $39\Omega$  and  $0.3pF$ ) between  $T_{OUTC}$  and  $T_{OUTA}$  ([Figure 1](#)).

**Note 5:**  $LD_{DC} = I_{DC} + I_{MOD} \times (DE + R \times (1 - DE)/(50 + R)/2)$ , where  $LD_{DC}$  is the effective laser DC current,  $I_{DC}$  is the DC DAC current,  $I_{MOD}$  is the modulation DAC current,  $DE$  is the deemphasis percentage, and  $R$  is the differential laser load resistance. Example: For  $R = 5\Omega$  and  $DE = 6.25\%$ ,  $LD_{DC} = I_{DC} + 0.105 \times I_{MOD}$ .

**Note 6:** Guaranteed by design and characterization.

**Note 7:** Stability is defined as  $[(I_{MEASURED}) - (I_{REFERENCE})]/(I_{REFERENCE})$  over the listed current/temperature range and  $V_{CCT} = V_{CC} = V_{CCREF} \pm 5\%$ ,  $V_{CCREF} = 3.3V$ . Reference current measured at  $V_{CCREF}$  and  $T_{REF} = +25^{\circ}C$ .

**Note 8:**  $LD_{MOD} = I_{MOD} \times (1 - DE) \times 50/(50 + R)$ , where  $LD_{MOD}$  is the effective laser modulation current,  $I_{MOD}$  is the modulation DAC current,  $DE$  is the deemphasis percentage, and  $R$  is the differential laser load resistance. Example: For  $R = 5\Omega$  and  $DE = 6.25\%$ ,  $LD_{MOD} = 0.852 \times I_{MOD}$ .

**Note 9:** Equivalent  $2^{23} - 1$  PRBS pattern =  $2^7 - 1$  PRBS + 72 zeros +  $2^7 - 1$  PRBS + 72 ones.

**Note 10:** These limits are based on simulated values.

# MAX3948

## 11.3Gbps, Low-Power, DC-Coupled Laser Driver

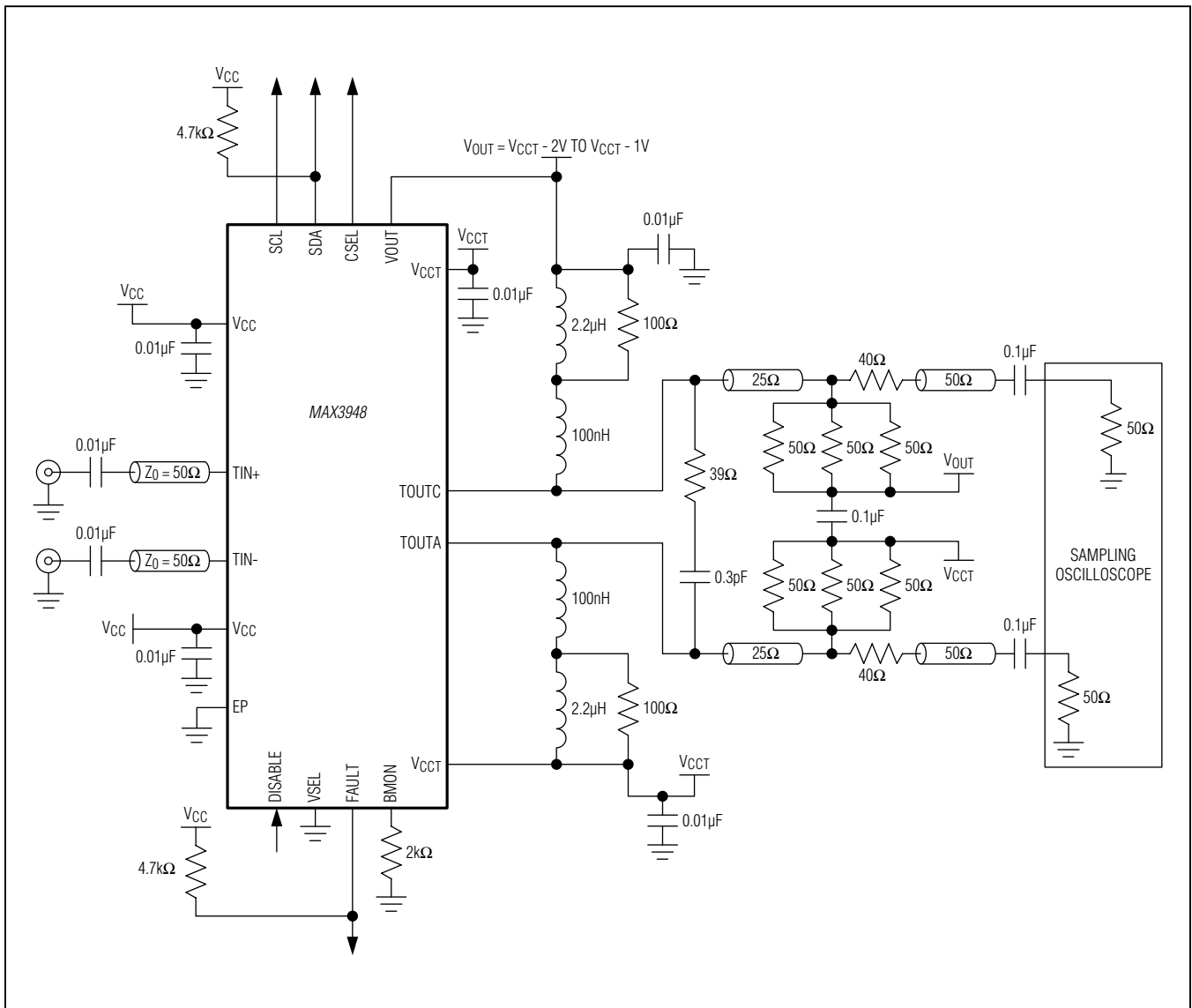

Figure 1. AC Test Setup

## 11.3Gbps, Low-Power, DC-Coupled Laser Driver

### Typical Operating Characteristics

(Typical values are at  $V_{CC} = V_{CC1} = 3.3V$ ,  $T_A = +25^\circ C$ , data pattern =  $2^7 - 1$  PRBS + 72 zeros +  $2^7 - 1$  PRBS (inverted) + 72 ones, unless otherwise noted.)

**10.3Gbps OPTICAL EYE DIAGRAM**

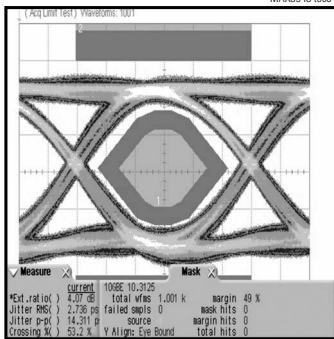

**10.3Gbps ELECTRICAL EYE DIAGRAM**

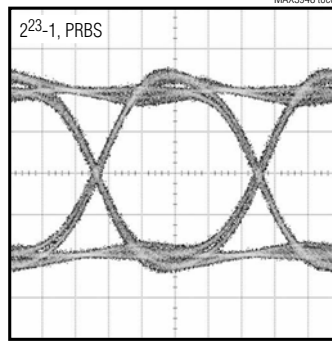

**INPUT DIFFERENTIAL RETURN LOSS vs. FREQUENCY**

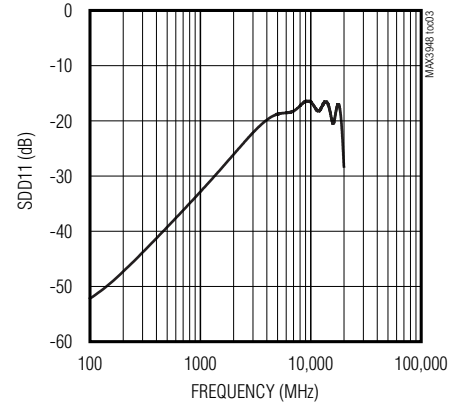

**INPUT COMMON-MODE RETURN LOSS vs. FREQUENCY**

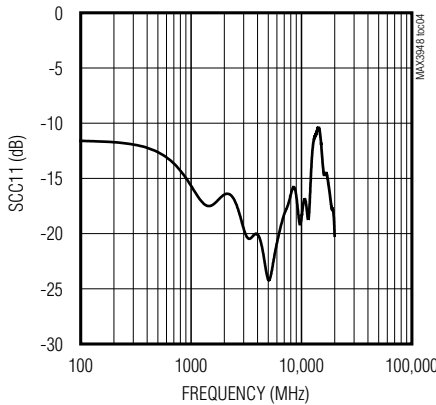

**INPUT DIFFERENTIAL TO COMMON-MODE RETURN LOSS vs. FREQUENCY**

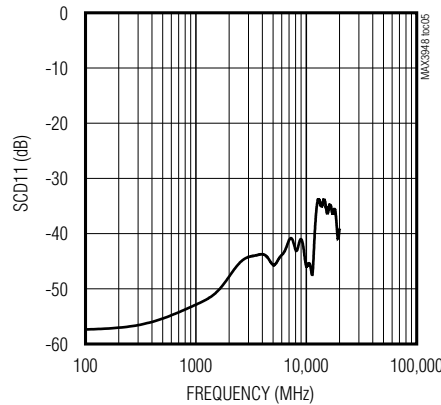

**OUTPUT DIFFERENTIAL RETURN LOSS vs. FREQUENCY**

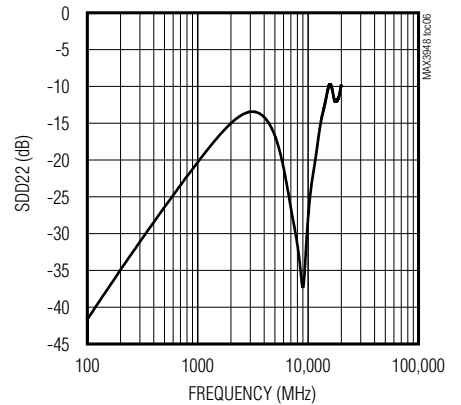

**OUTPUT COMMON-MODE RETURN LOSS vs. FREQUENCY**

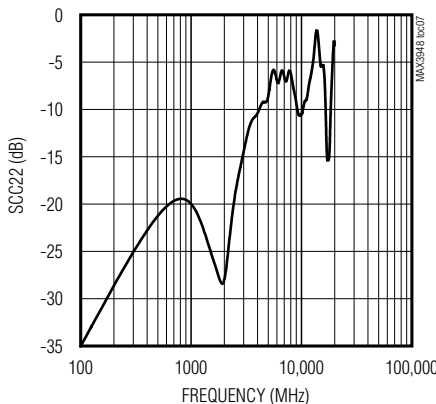

**RANDOM JITTER vs. MODULATION CURRENT (AT LOAD)**

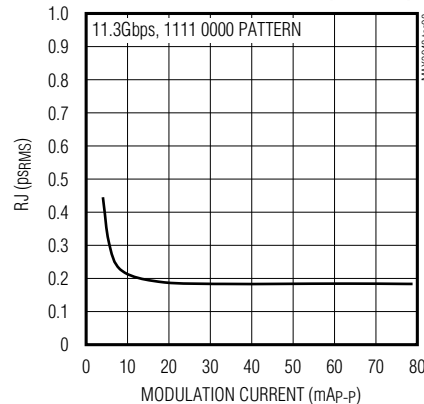

**SUPPLY CURRENT vs. TEMPERATURE (LD<sub>MOD</sub> = 40mA<sub>P-P</sub>, LD<sub>DC</sub> = 20mA)**

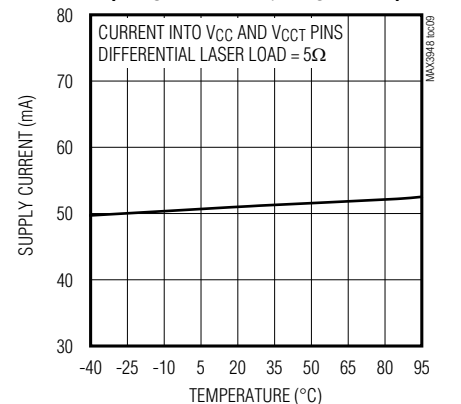



## 11.3Gbps, Low-Power, DC-Coupled Laser Driver

### Typical Operating Characteristics (continued)

(Typical values are at  $V_{CC} = V_{CC1} = 3.3V$ ,  $T_A = +25^\circ C$ , data pattern =  $2^7 - 1$  PRBS + 72 zeros +  $2^7 - 1$  PRBS (inverted) + 72 ones, unless otherwise noted.)

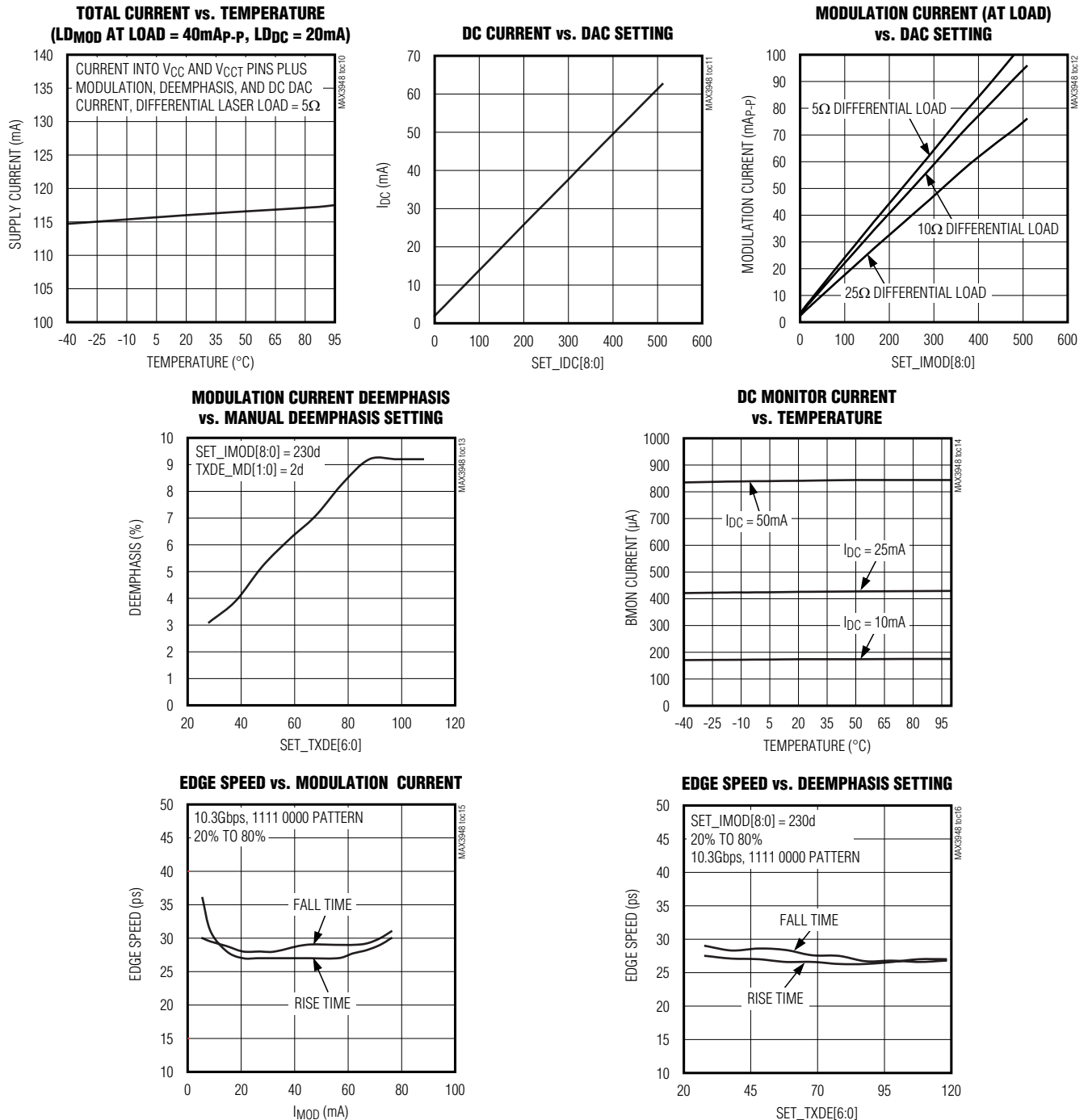

## 11.3Gbps, Low-Power, DC-Coupled Laser Driver

### Typical Operating Characteristics (continued)

(Typical values are at  $V_{CC} = V_{CCT} = 3.3V$ ,  $T_A = +25^\circ C$ , data pattern =  $2^7 - 1$  PRBS + 72 zeros +  $2^7 - 1$  PRBS (inverted) + 72 ones, unless otherwise noted.)

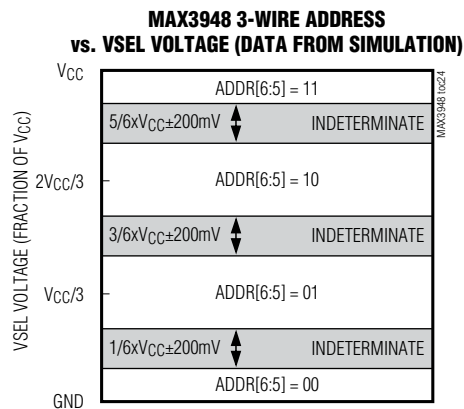
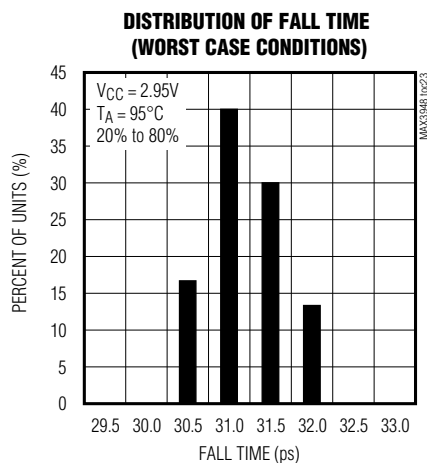
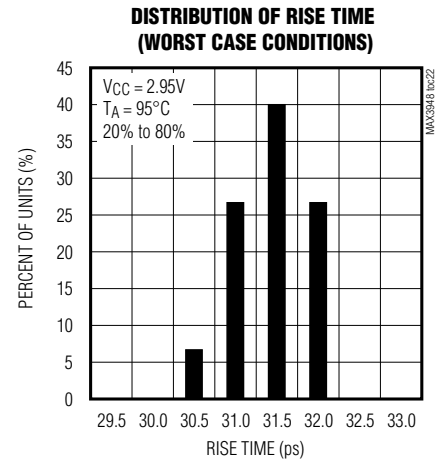
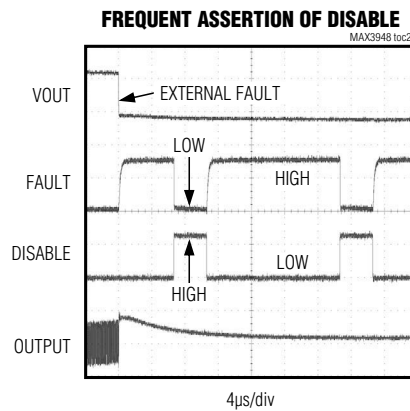
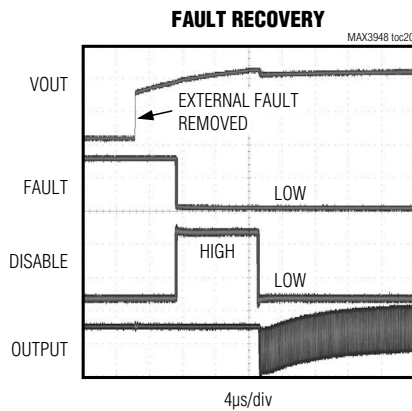
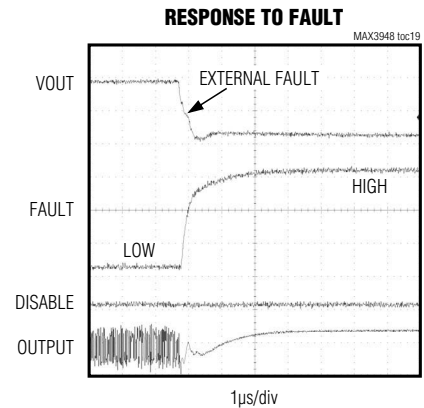
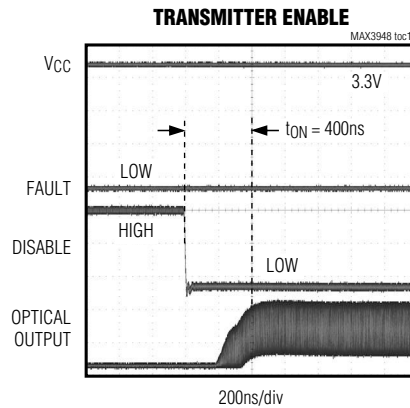
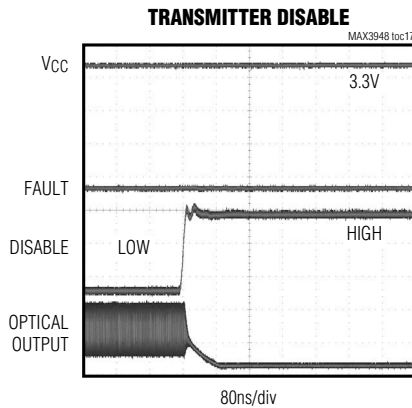

# MAX3948

## 11.3Gbps, Low-Power, DC-Coupled Laser Driver

### Pin Configuration

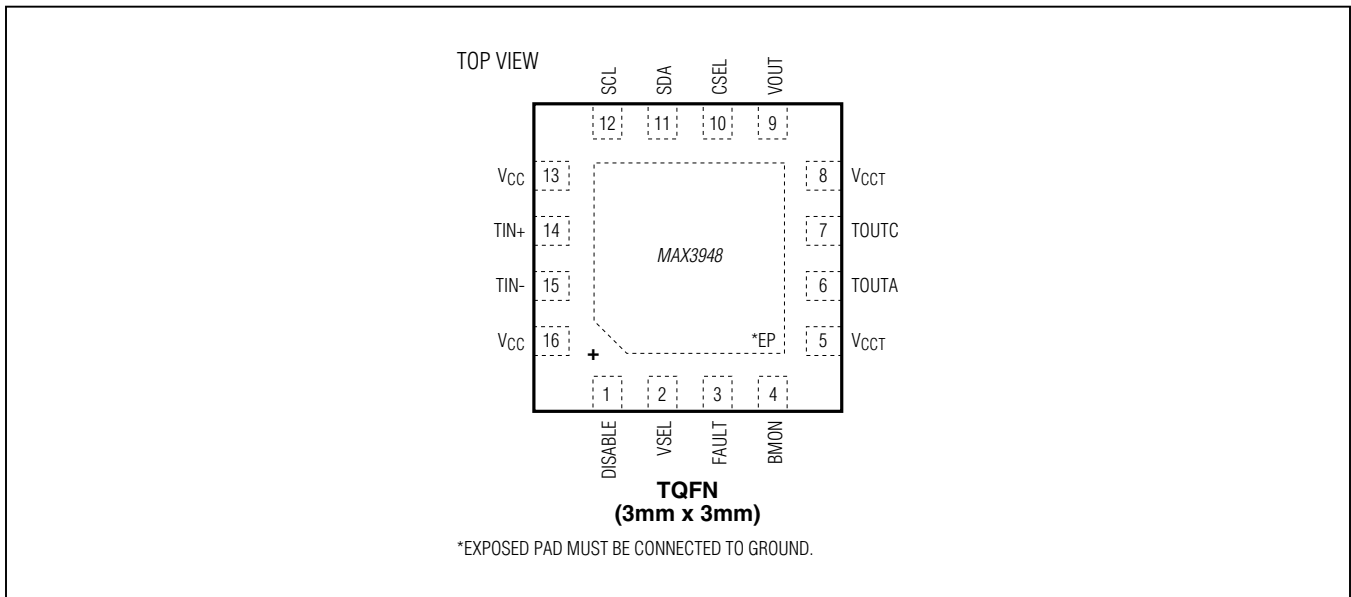

### Pin Description

| PIN | NAME    | FUNCTION   | EQUIVALENT CIRCUIT |
|-----|---------|--|--------------------|
| 1   | DISABLE | Disable Input, CMOS. Set to logic-low for normal operation. Logic-high or open disables both the modulation current and the DC current. Internally pulled up by a 7.5kΩ resistor to V <sub>CC</sub> .  |                    |
| 2   | VSEL    | 4-Level Input for SPI Device Address Detection. Connecting to V <sub>CC</sub> sets ADDR[6:5] to 11b, connecting to V <sub>CC</sub> x 2/3 sets ADDR[6:5] to 10b, connecting to V <sub>CC</sub> /3 sets ADDR[6:5] to 01b, and connecting to GND sets ADDR[6:5] to 00b. |                    |

## 11.3Gbps, Low-Power, DC-Coupled Laser Driver

### Pin Description (continued)

| PIN | NAME      | FUNCTION   | EQUIVALENT CIRCUIT |
|-----|-----------|--|--------------------|
| 3   | FAULT     | Fault Output, Open Drain. Logic-high indicates a fault condition has been detected. It remains high even after the fault condition has been removed. A logic-low occurs when the fault condition has been removed and the fault latch has been cleared by toggling DISABLE. FAULT should be pulled up to $V_{CC}$ by a $4.7k\Omega$ to $10k\Omega$ resistor. |                    |
| 4   | BMON      | Analog Laser DC Current Monitor Output. Current out of this pin develops a ground-referenced voltage across an external resistor that is proportional to the VOUT pin current. The current sourced by this pin is typically 1/60 the VOUT pin current.   |                    |
| 5,8 | $V_{CCT}$ | Power Supply. Provides supply voltage to the output block.   | —                  |
| 6   | TOUTA     | Inverting Laser Diode Modulation Current Output. Connect this pin to the anode of the laser diode.   |                    |
| 7   | TOUTC     | Noninverting Laser Diode Modulation Current Output. Connect this pin to the cathode of the laser diode.  |                    |

## 11.3Gbps, Low-Power, DC-Coupled Laser Driver

### Pin Description (continued)

| PIN | NAME | FUNCTION   | EQUIVALENT CIRCUIT   |
|-----|------|--|--|
| 9   | VOUT | Combined Current Return Path and Laser DC Current Output   | <p>The diagram shows a current source connected to the base of a transistor. The emitter of the transistor is connected to ground. The collector is connected to a diode, which is in series with another diode connected to V<sub>CCT</sub>. The output terminal VOUT is connected to the node between the two diodes.</p>                                    |
| 10  | CSEL | Chip-Select CMOS Input. Setting CSEL to logic-high starts a 3-wire command cycle. Setting CSEL to logic-low ends the cycle and resets the control state machine. Internally pulled down to GND by a 75kΩ resistor. | <p>The diagram shows the CSEL pin connected to two diodes for ESD protection, with the cathodes to ground and anodes to V<sub>CC</sub>. A 75kΩ resistor is connected between the pin and ground. The pin is also connected to the gates of two CMOS transistors (PMOS and NMOS) whose sources are connected to ground and drains to V<sub>CC</sub>.</p>        |
| 11  | SDA  | Serial Data Bidirectional CMOS Input. Also an open-drain output. This pin has a 75kΩ internal pullup, but requires an external 4.7kΩ to 10kΩ pullup resistor to V <sub>CC</sub> for proper operation.              | <p>The diagram shows the SDA pin connected to two diodes for ESD protection, with the cathodes to ground and anodes to V<sub>CC</sub>. A 75kΩ resistor is connected between the pin and V<sub>CC</sub>. The pin is also connected to the gates of two CMOS transistors (PMOS and NMOS) whose sources are connected to ground and drains to V<sub>CC</sub>.</p> |
| 12  | SCL  | Serial-Clock CMOS Input. This pin has an internal 75kΩ pulldown resistor to GND.   | <p>The diagram shows the SCL pin connected to two diodes for ESD protection, with the cathodes to ground and anodes to V<sub>CC</sub>. A 75kΩ resistor is connected between the pin and ground. The pin is also connected to the gates of two CMOS transistors (PMOS and NMOS) whose sources are connected to ground and drains to V<sub>CC</sub>.</p>         |

## 11.3Gbps, Low-Power, DC-Coupled Laser Driver

### Pin Description (continued)

| PIN    | NAME            | FUNCTION   | EQUIVALENT CIRCUIT |
|--------|-----------------|--|--------------------|
| 13, 16 | V <sub>CC</sub> | Power Supply. Provides supply voltage to core analog and digital circuitry.  | —                  |
| 14     | TIN+            | Noninverting Data Input. Input with internal 50Ω termination.  |                    |
| 15     | TIN-            | Inverting Data Input. Input with internal 50Ω termination.   |                    |
| —      | EP              | Exposed Pad (Ground). This is the only electrical connection to ground on the MAX3948 and must be soldered to the circuit board ground for proper thermal and electrical performance (see the <i>Exposed-Pad Package</i> section). | —                  |

# MAX3948

## 11.3Gbps, Low-Power, DC-Coupled Laser Driver

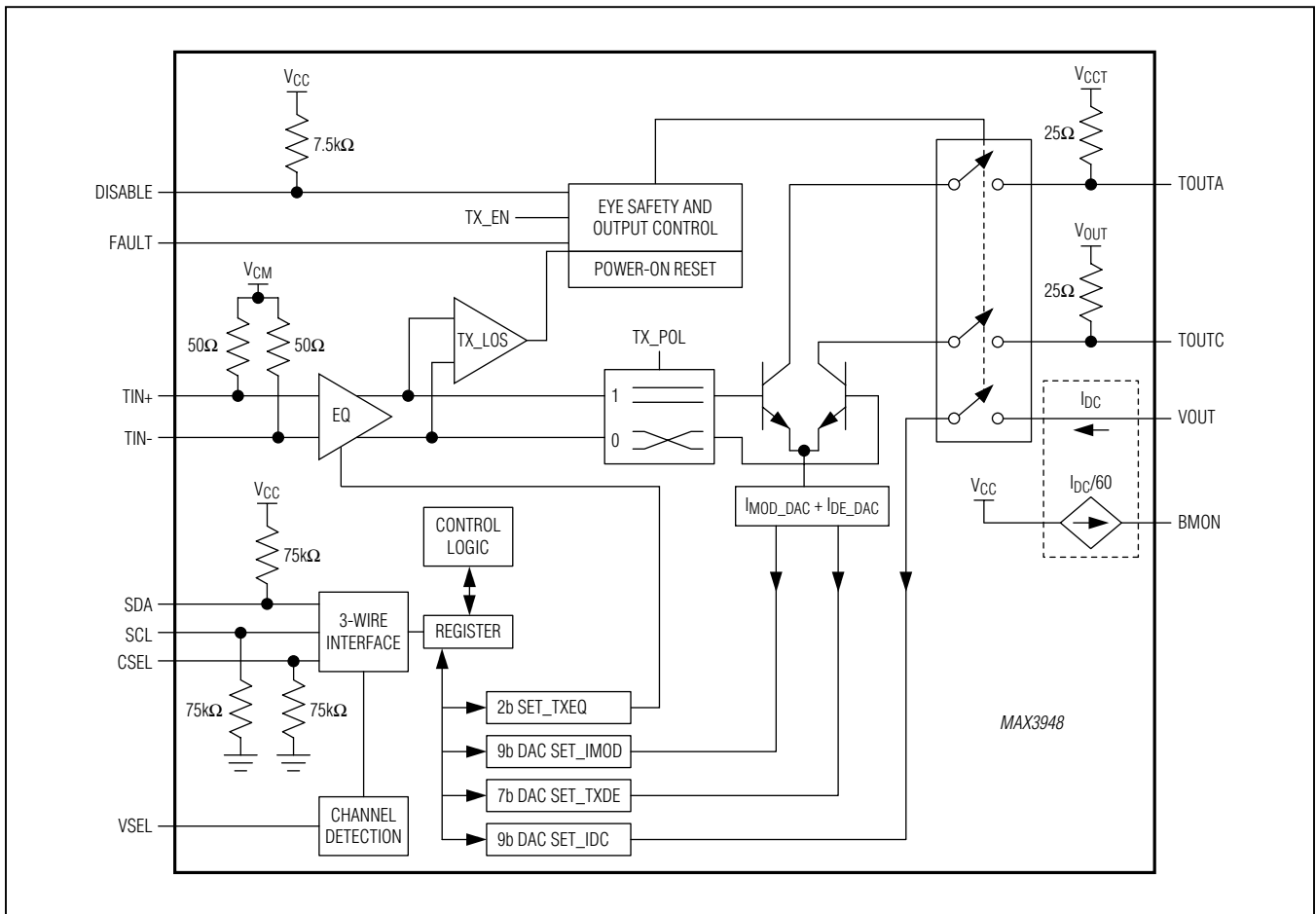

Figure 2. Functional Diagram

## 11.3Gbps, Low-Power, DC-Coupled Laser Driver

### Detailed Description

The MAX3948 SFP+/QSFP+ laser driver is designed to drive 5Ω to 10Ω TOSAs from 1Gbps to 11.3Gbps. It contains an input buffer with programmable equalization, DC and modulation current DACs, an output driver with adjustable deemphasis, power-on-reset circuitry, DC current monitor, programmable 3-wire address, and eye safety circuitry with maskable fault monitors. A 3-wire digital interface is used to control these functions.

#### Input Buffer with Programmable Equalization

The input is internally biased and terminated with 50Ω to a common-mode voltage. The first amplifier stage features a programmable equalizer for high-frequency losses including a SFP+/QSFP+ host connector. Equalization is controlled by the [SET\\_TXEQ](#) register ([Table 1](#)). The TX\_POL bit in the [TXCTRL](#) register controls the polarity of TOUTA and TOUTC vs. TIN+ and TIN-. A status indicator bit ([TXSTAT1](#) bit 5) monitors the presence of an AC input signal.

**Table 1. Input Equalization Control Register Settings**

| SET_TXEQ[1:0] |   | BOOST AT 5.16GHz (dB) |
|---------------|---|-----------------------|
| 0             | 0 | 1                     |
| 0             | 1 | 3                     |
| 1             | 1 | 5.5                   |

#### DC Current DAC

The DC current from the device is optimized to provide up to 61mA of DC current into a laser diode with 116μA resolution ([Figure 3](#)). The DC DAC current is controlled through the 3-wire digital interface using the [SET\\_IDC](#)[8:0], [IDCMAX](#)[7:0], and [DCINC](#)[4:0] bits.

For laser operation, the laser DC current can be set using the 9-bit [SET\\_IDC](#) DAC register. The upper 8 bits are set by the [SET\\_IDC](#)[8:1] register, commonly used during the initialization procedure after power-on reset (POR). The LSB (bit 0) of [SET\\_IDC](#) ([DCINC](#)[7]) is initialized to zero after POR and can be updated using the [DCINC](#) register.

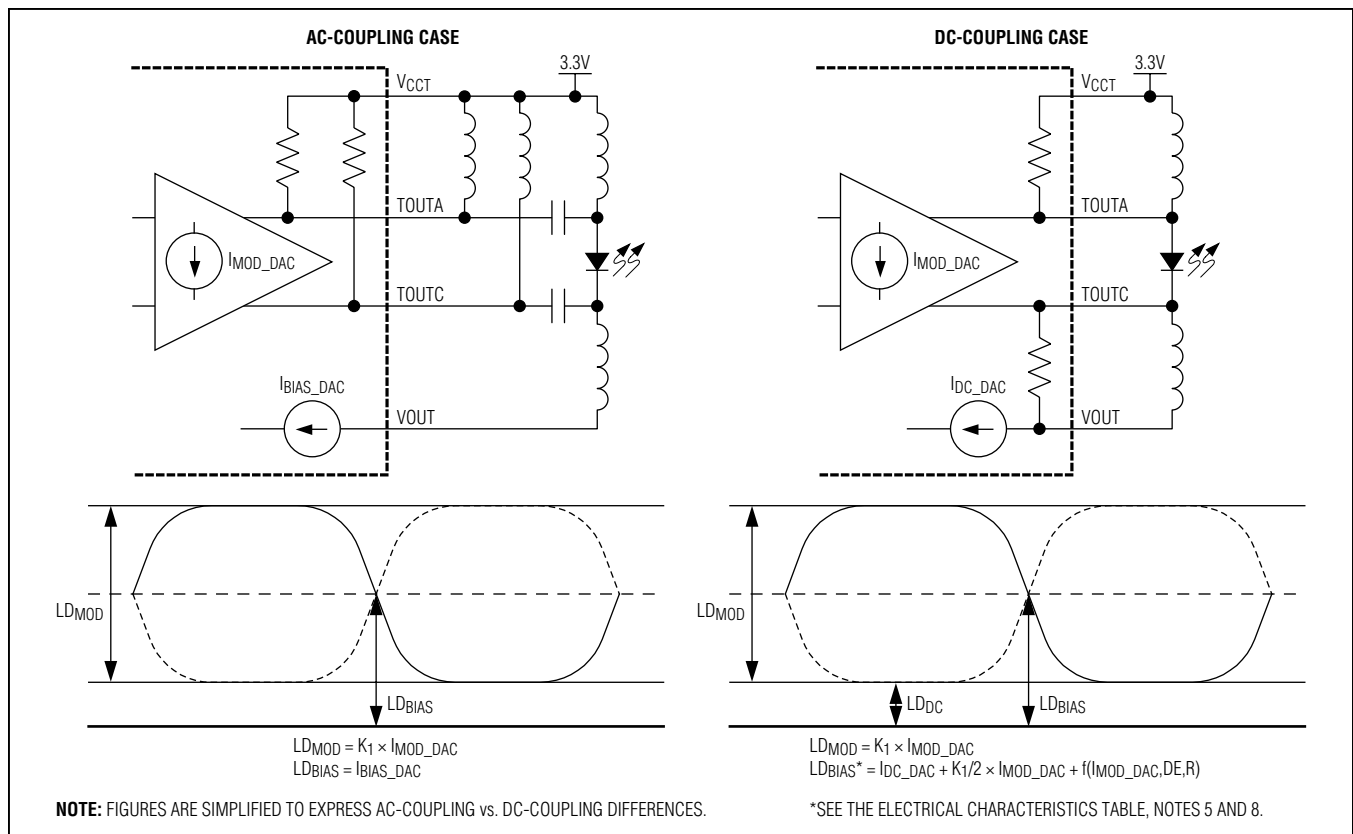

Figure 3. AC-/DC-Coupling Cases



## 11.3Gbps, Low-Power, DC-Coupled Laser Driver

The [IDCMAX](#) register limits the maximum [SET\\_IDC](#)[8:1] DAC code.

After initialization the value of the [SET\\_IDC](#) DAC register should be updated using the [DCINC](#) register to optimize cycle time and enhance laser safety. The [DCINC](#) register is an 8-bit register. The first 5 bits of [DCINC](#) contain the increment information in two's complement format. Increment values range from -16 to +15 LSBs. If the updated value of [SET\\_IDC](#)[8:1] exceeds [IDCMAX](#)[7:0], the IDCERR warning flag is set and [SET\\_IDC](#)[8:1] is set to [IDCMAX](#)[7:0].

### Modulation Current DAC

The modulation current from the MAX3948 is optimized to provide up to 85mA of modulation current into a 5Ω laser load with 210μA resolution. The modulation current is controlled through the 3-wire digital interface using the [SET\\_IMOD](#)[8:1], [IMODMAX](#)[7:0], [MODINC](#)[7:0], and [SET\\_TXDE](#) registers.

For laser operation, the laser modulation current can be set using the 9-bit [SET\\_IMOD](#) DAC. The upper 8 bits are programmed through the [SET\\_IMOD](#)[8:1] register, commonly used during the initialization procedure after POR. The LSB (bit 0) of [SET\\_IMOD](#) ([MODINC](#)[7]) is initialized to zero after POR and can be updated using the [MODINC](#) register. The [IMODMAX](#) register limits the maximum [SET\\_IMOD](#)[8:1] DAC code.

After initialization the value of the [SET\\_IMOD](#) DAC register should be updated using the [MODINC](#)[4:0] bits to optimize cycle time and enhance laser safety. The [MODINC](#) register is an 8-bit register. The first 5 bits of [MODINC](#) contain the increment information in two's complement format. Increment values range from -16 to +15 LSBs. If the updated value of [SET\\_IMOD](#)[8:1] exceeds [IMODMAX](#)[7:0], the IMODERR warning flag is set and [SET\\_IMOD](#)[8:1] is set to [IMODMAX](#)[7:0].

Effective modulation current seen by the laser is actually the combination of the DAC current generated by the [SET\\_IMOD](#)[8:0] register ( $I_{MOD}$ ), deemphasis setting (DE), and differential laser load (R). It is calculated by the following formula:

$$LD_{MOD} = I_{MOD} \times 50 \times (1 - DE) / (50 + R)$$

### Output Driver

This device is optimized to drive a differential TOSA with a 25Ω flex circuit. The unique design of the output stage

enables DC-coupling to unmatched TOSAs with laser diode impedances ranging from 5Ω to 10Ω. The output stage also features programmable deemphasis that can be set as a percentage of the modulation current. The deemphasis function is controlled by the [TXCTRL](#)[4:3] and the [SET\\_TXDE](#) registers.

### Power-On Reset (POR)

Power-on reset ensures that the laser is off until the supply voltage has reached a specified threshold (2.75V). After power-on reset, TX\_EN is 0 and DC current and modulation current DACs default to small codes. In the case of a POR, all registers are reset to their default values.

### BMON Function

The current out of the BMON pin is typically 1/60th the value of the current into the VOUT pin. The total resistance to ground at BMON sets the voltage.

### VSEL Function

The VSEL pin is an analog input that sets the 3-wire address for the MAX3948. The pin can be set to either  $V_{CC}$ ,  $V_{CC} \times 2/3$ ,  $V_{CC}/3$ , or to GND ([Table 2](#)). This allows up to four MAX3948s to be operated on a single 3-wire bus, each with their own address.

**Table 2. 3-Wire Address Selection**

| VSEL                | ADDR[6:5] |
|---------------------|-----------|
| $V_{CC}$            | 11b       |
| $V_{CC} \times 2/3$ | 10b       |
| $V_{CC}/3$          | 01b       |
| GND                 | 00b       |

### Eye Safety and Output Control Circuitry

The safety and output control circuitry includes the disable pin (DISABLE) and enable bit (TX\_EN), along with a FAULT indicator and fault detectors ([Figure 4](#)). A fault condition triggers the FAULT pin to go high and a corresponding bit is set in the [TXSTAT1](#) register. The MAX3948 has two types of faults: hard faults and soft faults. Hard faults are maskable, trigger the FAULT pin (transitions high), disable the outputs and are stored in the [TXSTAT1](#) register. Soft faults serve as warnings, do not disable the outputs, and are stored in the [TXSTAT2](#) register.

## 11.3Gbps, Low-Power, DC-Coupled Laser Driver

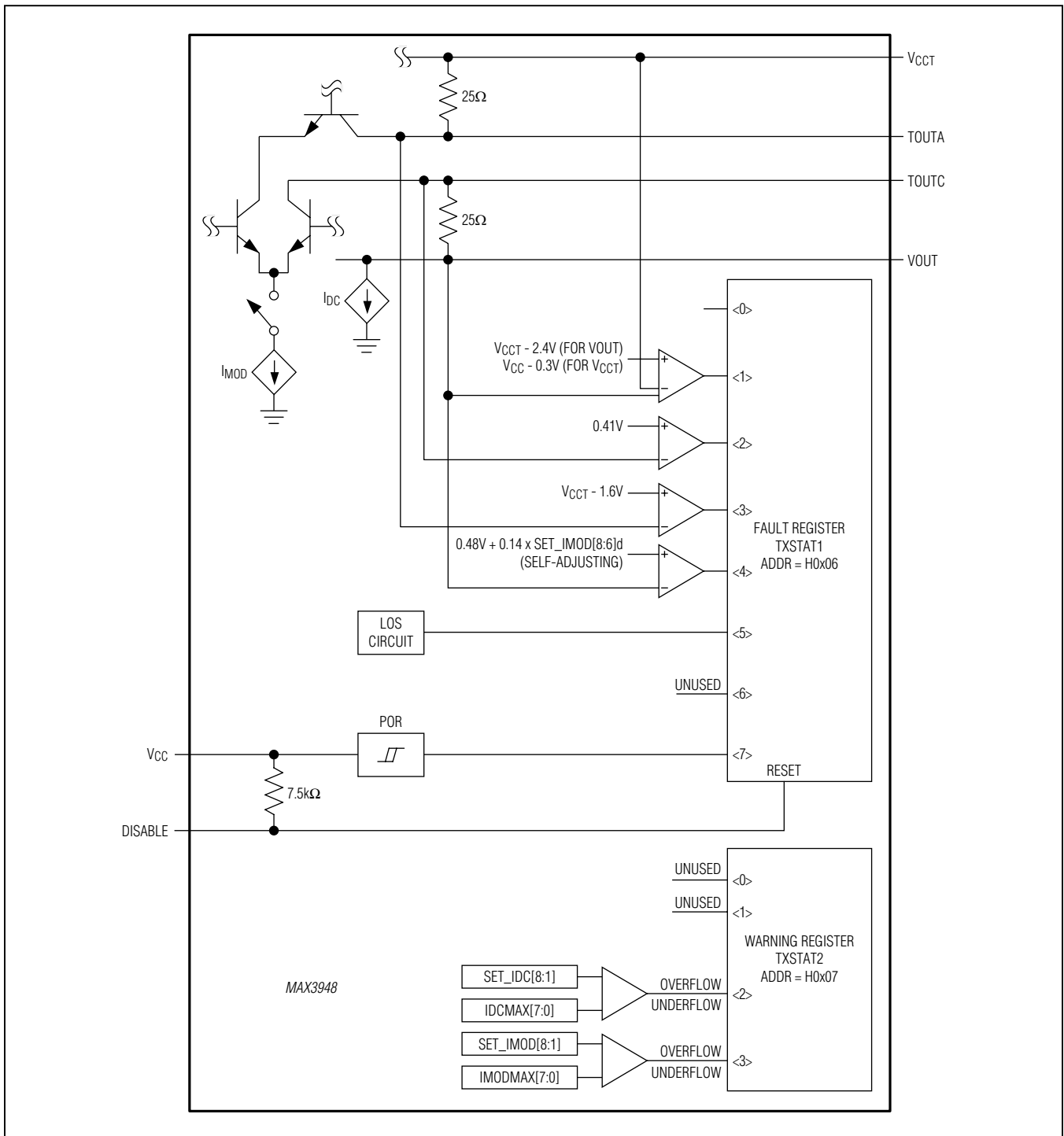

Figure 4. Eye Safety Circuitry

## 11.3Gbps, Low-Power, DC-Coupled Laser Driver

The FAULT pin is a latched output that can be cleared by toggling the DISABLE pin. Toggling the DISABLE pin also clears the [TXSTAT1](#) and [TXSTAT2](#) registers. A single-point

failure can be a short to  $V_{CC}$  or GND. [Table 3](#) shows the circuit response to various single-point failures.

**Table 3. Circuit Response to Single-Point Failure**

| PIN    | NAME      | SHORT TO $V_{CC}$                                   | SHORT TO GND   | OPEN   |
|--------|-----------|---|--|--|
| 1      | DISABLE   | Disabled  | Normal (Note 1). Can only be disabled by other means.  | Disabled   |
| 2      | VSEL      | Normal (Note 2)                                     | Normal (Note 2)  | Normal (Note 2)  |
| 3      | FAULT     | Normal (Note 2)                                     | Normal (Note 1)  | Normal (Note 2)  |
| 4      | BMON      | Normal (Note 2)                                     | Normal (Note 2)  | Normal (Note 2)  |
| 5, 8   | $V_{CCT}$ | Normal  | Disabled—Fault (external supply shorted) (Note 3)      | Redundant path (Note 4)                                      |
| 6      | TOUTA     | Laser modulation current is reduced                 | Disabled (hard fault)                                  | Laser modulation current is reduced or disabled (hard fault) |
| 7      | TOUTC     | Laser modulation current is reduced or off          | Disabled (hard fault)                                  | Laser modulation current is reduced or disabled (hard fault) |
| 9      | VOUT      | IDC is on, but not delivered to the laser; no fault | Disabled (hard fault)                                  | Disabled (hard fault)  |
| 10     | CSEL      | Normal (Note 2)                                     | Normal (Note 2)  | Normal (Note 2)  |
| 11     | SDA       | Normal (Note 2)                                     | Normal (Note 2)  | Normal (Note 2)  |
| 12     | SCL       | Normal (Note 2)                                     | Normal (Note 2)  | Normal (Note 2)  |
| 13, 16 | $V_{CC}$  | Normal  | Disabled—Hard fault (external supply shorted) (Note 3) | Redundant path (Note 4)                                      |
| 14     | TIN+      | Disabled (hard fault)                               | Disabled (hard fault)                                  | Normal (Note 2) or disabled (hard fault)                     |
| 15     | TIN-      | Disabled (hard fault)                               | Disabled (hard fault)                                  | Normal (Note 2) or disabled (hard fault)                     |

**Note 1:** Normal operation—Does not affect the laser power.

**Note 2:** Pin functionality might be affected, which could affect laser power/performance.

**Note 3:** Supply-short current is assumed to be primarily on the circuit board (outside this device) and the main supply is collapsed by the short.

**Note 4:** Normal in functionality, but performance could be affected.

**Warning:** Shorted to  $V_{CC}$  or shorted to ground on some pins can violate the [Absolute Maximum Ratings](#).

## 11.3Gbps, Low-Power, DC-Coupled Laser Driver

### 3-Wire Interface

The MAX3948 implements a proprietary 3-wire digital interface. An external controller generates the clock. The 3-wire interface consists of an SDA bidirectional data line, a SCL clock signal input, and a CSEL chip-select input (active high). The external master initiates a data transfer by asserting the CSEL pin. The master starts to generate a clock signal after the CSEL pin has been set to a logic-high. All data transfers are most significant bit (MSB) first.

### Protocol

Each operation consists of 16-bit transfers (15-bit address/data, 1-bit RWN). The bus master generates 16 clock cycles to SCL. All operations transfer 8 bits to the MAX3948. The RWN bit determines if the cycle is read or write ([Table 5](#)).

### Register Addresses

The MAX3948 contains 13 registers available for programming. [Table 6](#) shows the registers and addresses.

### Write Mode (RWN = 0)

The master generates 16 clock cycles at SCL in total. The master outputs a total of 16 bits (MSB first) to the SDA line at the falling edge of the clock. The master closes

the transmission by setting CSEL to 0. [Figure 5](#) shows the interface timing.

### Read Mode (RWN = 1)

The master generates 16 clock cycles at SCL in total. The master outputs a total of 8 bits (MSB first) to the SDA line at the falling edge of the clock. The SDA line is released after the RWN bit has been transmitted. The slave outputs 8 bits of data (MSB first) at the rising edge of the clock. The master closes the transmission by setting CSEL to 0. [Figure 5](#) shows the interface timing.

### Mode Control

Normal mode allows read-only instruction for all registers. Only the [MODINC](#) and [DCINC](#) registers can be updated during normal mode. Doing so speeds up the laser control update through the 3-wire interface by a factor of two. The normal mode is the default mode.

Setup mode allows the master to write unrestricted data into any register except the status ([TXSTAT1](#), [TXSTAT2](#)) registers. To enter the setup mode, the [MODECTRL](#) register (address = H0x0F) must be set to 12h. After the [MODECTRL](#) register has been set to 12h, the next operation is unrestricted. The setup mode is automatically exited after the operation is finished. This sequence must be repeated if further unrestricted settings are necessary.

Broadcast mode allows for faster configuration of multiple MAX3948 ICs by causing the address selection bits (ADDR[6:5]) to be ignored so all MAX3948s on the bus can be written to simultaneously.

A block write in broadcast mode can start at any of the addresses in [Table 4](#). The block write is achieved by holding the CSEL pin high to lengthen the SPI cycle. The register address increments automatically through the sequence listed in [Table 4](#) and wraps from [TXCTRL](#) to [FMSK](#). The block write ends once the CSEL pin is asserted low.

**Table 4. Broadcast Mode Register Initialization Sequence**

| ADDRESS | NAME     |
|---------|----------|
| H0x0F   | FMSK     |
| H0x10   | SET_TXDE |
| H0x11   | SET_TXEQ |
| H0x0A   | IMODMAX  |
| H0x0B   | IDCMAX   |
| H0x08   | SET_IDC  |
| H0x09   | SET_IMOD |
| H0x05   | TXCTRL   |

**Table 5. Digital Communication Word Structure**

| BIT       |    |    |    |    |    |   |     |           |   |   |   |   |   |   |   |
|-----------|----|----|----|----|----|---|-----|-----------|---|---|---|---|---|---|---|
| 15        | 14 | 13 | 12 | 11 | 10 | 9 | 8   | 7         | 6 | 5 | 4 | 3 | 2 | 1 | 0 |
| ADDR[6:0] |    |    |    |    |    |   | RWN | DATA[7:0] |   |   |   |   |   |   |   |

## 11.3Gbps, Low-Power, DC-Coupled Laser Driver

**Table 6. Register Descriptions and Addresses**

| ADDRESS | NAME     | FUNCTION                                      |
|---------|----------|---|
| H0x05   | TXCTRL   | Transmitter Control Register                  |
| H0x06   | TXSTAT1  | Transmitter Status Register 1                 |
| H0x07   | TXSTAT2  | Transmitter Status Register 2                 |
| H0x08   | SET_IDC  | DC Current Setting Register                   |
| H0x09   | SET_IMOD | Modulation Current Setting Register           |
| H0x0A   | IMODMAX  | Maximum Modulation Current Setting Register   |
| H0x0B   | IDCMAX   | Maximum DC Current Setting Register           |
| H0x0C   | MODINC   | Modulation Current Increment Setting Register |
| H0x0D   | DCINC    | DC Current Increment Setting Register         |
| H0x0E   | MODECTRL | Mode Control Register                         |
| H0x0F   | FMSK     | Fault Mask Register                           |
| H0x10   | SET_TXDE | Transmitter Deemphasis Control Register       |
| H0x11   | SET_TXEQ | Transmitter Equalization Control Register     |

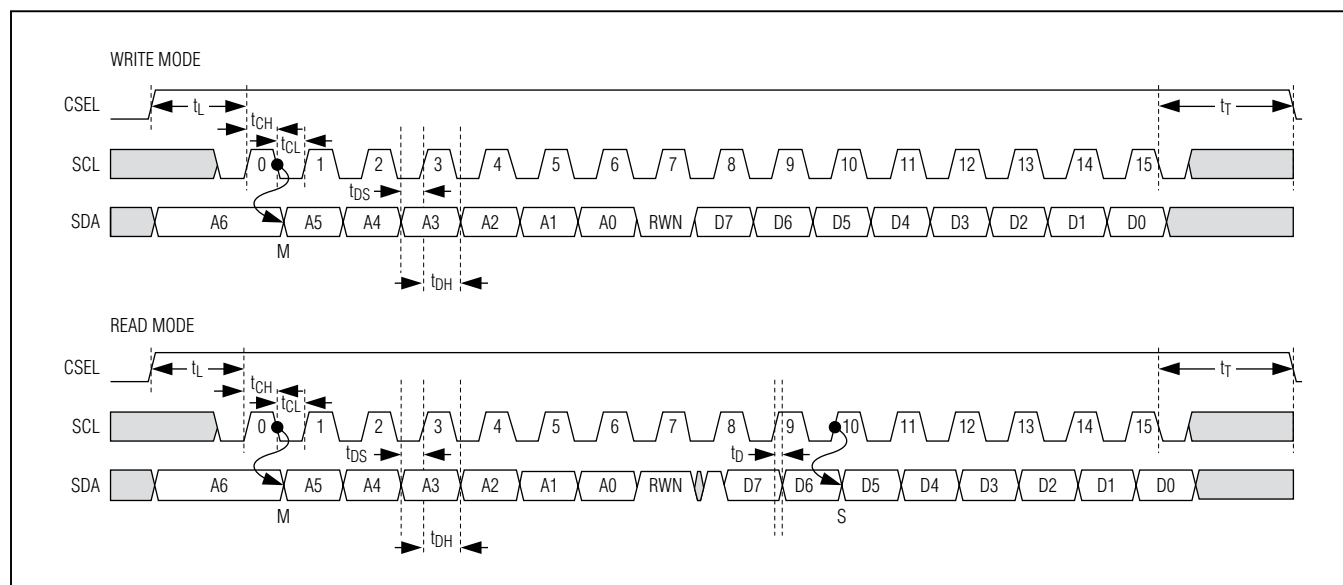

Figure 5. Timing for 3-Wire Digital Interface

## 11.3Gbps, Low-Power, DC-Coupled Laser Driver

### Register Descriptions

#### Transmitter Control Register (TXCTRL), Address: H0x05

| Bit        | D7       | D6       | D5       | D4         | D3         | D2      | D1     | D0    |
|------------|----------|----------|----------|------------|------------|---------|--------|-------|
| Bit Name   | RESERVED | RESERVED | RESERVED | TXDE_MD[1] | TXDE_MD[0] | SOFTRES | TX_POL | TX_EN |
| Read/Write | R/W      | R/W      | R/W      | R/W        | R/W        | R/W     | R/W    | R/W   |
| POR State  | 0        | 0        | 0        | 0          | 0          | 0       | 1      | 0     |

The TXCTRL register sets the device's operation.

| BIT    | NAME     | DESCRIPTION   |
|--------|----------|---|
| D[7:5] | RESERVED | Reserved Bits. <b>The default state for these bits is 0 and they must be kept 0 when the register is accessed for a write operation.</b>  |
| D[4:3] | TXDE_MD  | Controls the mode of the transmit output deemphasis circuitry.<br>00 = Deemphasis is fixed at 6% of the modulation amplitude<br>01 = Deemphasis is fixed at 3% of the modulation amplitude<br>10 = Deemphasis is programmed by SET_TXDE register setting (3% to 9%)<br>11 = Deemphasis is at its maximum of ~9% |
| D2     | SOFTRES  | Resets all registers to their default values (TXCTRL[1:0] must be = 10b during the write to SOFTRES for the registers to be set to their default values).<br>0 = Normal operation<br>1 = Reset  |
| D1     | TX_POL   | Controls the polarity of the transmit signal path.<br>0 = Inverse<br>1 = Normal operation   |
| D0     | TX_EN    | Enables or disables the transmit circuitry.<br>0 = Disabled<br>1 = Enabled  |

## 11.3Gbps, Low-Power, DC-Coupled Laser Driver

**Transmitter Status Register 1 (TXSTAT1), Address: H0x06**

| Bit             | D7<br>(STICKY) | D6<br>(STICKY) | D5<br>(STICKY) | D4<br>(STICKY) | D3<br>(STICKY) | D2<br>(STICKY) | D1<br>(STICKY) | D0<br>(STICKY) |
|-----------------|----------------|----------------|----------------|----------------|----------------|----------------|----------------|----------------|
| Bit Name        | FST[7]         | FST[6]         | FST[5]         | FST[4]         | FST[3]         | FST[2]         | FST[1]         | FST[0]         |
| Read/Write      | R              | R              | R              | R              | R              | R              | R              | R              |
| POR State       | 1              | X              | X              | X              | X              | X              | X              | X              |
| Reset Upon Read | Yes            | Yes            | Yes            | Yes            | Yes            | Yes            | Yes            | Yes            |

The TXSTAT1 register is a device status register.

| BIT | NAME   | DESCRIPTION   |
|-----|--------|---|
| D7  | FST[7] | When the $V_{CC}$ supply voltage is below 2.3V, the POR circuitry reports a FAULT and <b>communication to the SPI cannot be performed</b> . Once the $V_{CC}$ supply voltage is above 2.75V, the POR resets all registers to their default values and the FAULT latch is cleared.   |
| D6  | FST[6] | Reserved.   |
| D5  | FST[5] | Indicates low or no AC signal at the inputs, a hard fault is reported unless masked.  |
| D4  | FST[4] | Indicates VOUT too low condition. Intended to be used as a warning/soft fault rather than a hard fault. In normal operation, FMSK[4] should be kept at logic 1 to convert this to a soft fault behavior. Self-adjustable threshold = $0.48V + 0.14V \times SET\_IMOD[8:6]$ (decimal value 0 to 7). A logic 1 can indicate marginal power-supply headroom. |
| D3  | FST[3] | Indicates TOUTA open or shorted to GND condition, threshold = $V_{CCT} - 1.6V$ , a hard fault is reported unless masked.  |
| D2  | FST[2] | Indicates TOUTC open or shorted to GND condition, threshold = 0.41V, a hard fault is reported unless masked.  |
| D1  | FST[1] | Indicates VOUT or $V_{CCT}$ open or shorted to GND conditions, threshold ( $V_{CCT}$ ) = $V_{CC} - 0.3V$ , threshold (VOUT) = $V_{CCT} - 2.4V$ , a hard fault is reported unless masked.  |
| D0  | FST[0] | Copy of a FAULT signal.   |

**Transmitter Status Register 2 (TXSTAT2), Address: H0x07**

| Bit             | D7 | D6 | D5 | D4 | D3<br>(STICKY) | D2<br>(STICKY) | D1 | D0 |
|-----------------|----|----|----|----|----------------|----------------|----|----|
| Bit Name        | X  | X  | X  | X  | IMODERR        | IDCERR         | X  | X  |
| Read/Write      | X  | X  | X  | X  | R              | R              | X  | X  |
| POR State       | X  | X  | X  | X  | 0              | 0              | X  | X  |
| Reset Upon Read | X  | X  | X  | X  | Yes            | Yes            | X  | X  |

The TXSTAT2 register is a device status register.

| BIT | NAME    | DESCRIPTION  |
|-----|---------|--|
| D3  | IMODERR | Modulation current overflow (on increment) or underflow (on decrement) error. Overflow occurs if result > IMODMAX. In overflow condition, SET_IMOD[8:1] = IMODMAX[7:0]. Underflow occurs if result < 0. In underflow condition, SET_IMOD[8:0] = 0. |
| D2  | IDCERR  | DC current overflow (on increment) or underflow (on decrement) error. Overflow occurs if result > IDCMAX. In overflow condition, SET_IDC[8:1] = IDCMAX[7:0]. Underflow occurs if result < 0. In underflow condition, SET_IDC[8:0] = 0.             |

## 11.3Gbps, Low-Power, DC-Coupled Laser Driver

**DC Current Setting Register (SET\_IDC), Address: H0x08**

| Bit        | D7           | D6           | D5           | D4           | D3           | D2           | D1           | D0           |
|------------|--------------|--------------|--------------|--------------|--------------|--------------|--------------|--------------|
| Bit Name   | SET_IBIAS[8] | SET_IBIAS[7] | SET_IBIAS[6] | SET_IBIAS[5] | SET_IBIAS[4] | SET_IBIAS[3] | SET_IBIAS[2] | SET_IBIAS[1] |
| Read/Write | R/W          | R/W          | R/W          | R/W          | R/W          | R/W          | R/W          | R/W          |
| POR State  | 0            | 0            | 0            | 0            | 0            | 0            | 0            | 1            |

The SET\_BIAS register sets the laser bias current DAC.

| BIT    | NAME           | DESCRIPTION   |
|--------|----------------|---|
| D[7:0] | SET_IBIAS[8:1] | The bias current DAC is controlled by a total of 9 bits. The SET_IBIAS[8:1] bits are used to set the bias current with even denominations from 0 to 510 bits. The LSB (SET_IBIAS[0]) bit is controlled by the BIASINC register and is used to set the odd denominations in the SET_IBIAS[8:0]. Any direct write to SET_IBIAS[8:1] resets the LSB. |

**Modulation Current Setting Register (SET\_IMOD), Address: H0x09**

| Bit        | D7          | D6          | D5          | D4          | D3          | D2          | D1          | D0          |
|------------|-------------|-------------|-------------|-------------|-------------|-------------|-------------|-------------|
| Bit Name   | SET_IMOD[8] | SET_IMOD[7] | SET_IMOD[6] | SET_IMOD[5] | SET_IMOD[4] | SET_IMOD[3] | SET_IMOD[2] | SET_IMOD[1] |
| Read/Write | R/W         | R/W         | R/W         | R/W         | R/W         | R/W         | R/W         | R/W         |
| POR State  | 0           | 0           | 0           | 0           | 0           | 1           | 0           | 0           |

The SET\_IMOD register sets the laser modulation current DAC.

| BIT    | NAME          | DESCRIPTION   |
|--------|---------------|---|
| D[7:0] | SET_IMOD[8:1] | The mod current DAC is controlled by a total of 9 bits. The SET_IMOD[8:1] bits are used to set the modulation current with even denominations from 0 to 510 bits. The LSB (SET_IMOD[0]) bit is controlled by the MODINC register and is used to set the odd denominations in the SET_IMOD[8:0]. Any direct write to SET_IMOD[8:1] resets the LSB. |



## 11.3Gbps, Low-Power, DC-Coupled Laser Driver

### Maximum Modulation Current Setting Register (IMODMAX), Address: H0x0A

| Bit        | D7         | D6         | D5         | D4         | D3         | D2         | D1         | D0         |
|------------|------------|------------|------------|------------|------------|------------|------------|------------|
| Bit Name   | IMODMAX[7] | IMODMAX[6] | IMODMAX[5] | IMODMAX[4] | IMODMAX[3] | IMODMAX[2] | IMODMAX[1] | IMODMAX[0] |
| Read/Write | R/W        | R/W        | R/W        | R/W        | R/W        | R/W        | R/W        | R/W        |
| POR State  | 0          | 0          | 1          | 0          | 0          | 0          | 0          | 0          |

The IMODMAX register sets the upper limit of modulation current.

| BIT    | NAME         | DESCRIPTION   |
|--------|--------------|---|
| D[7:0] | IMODMAX[7:0] | The IMODMAX register is an 8-bit register that can be used to limit the maximum modulation current. IMODMAX[7:0] is continuously compared to SET_IMOD[8:1]. |

### Maximum DC Current Setting Register (IDCMAX), Address: H0x0B

| Bit        | D7          | D6          | D5          | D4          | D3          | D2          | D1          | D0          |
|------------|-------------|-------------|-------------|-------------|-------------|-------------|-------------|-------------|
| Bit Name   | IBIASMAX[7] | IBIASMAX[6] | IBIASMAX[5] | IBIASMAX[4] | IBIASMAX[3] | IBIASMAX[2] | IBIASMAX[1] | IBIASMAX[0] |
| Read/Write | R/W         | R/W         | R/W         | R/W         | R/W         | R/W         | R/W         | R/W         |
| POR State  | 0           | 0           | 1           | 0           | 0           | 0           | 0           | 0           |

The IBIASMAX register sets the upper limit of bias current.

| BIT    | NAME          | DESCRIPTION  |
|--------|---------------|--|
| D[7:0] | IBIASMAX[7:0] | The IBIASMAX register is an 8-bit register that can be used to limit the maximum bias current. IBIASMAX[7:0] is continuously compared to SET_IBIAS[8:1]. |

### Modulation Current Increment Setting Register (MODINC), Address: H0x0C

| Bit        | D7          | D6 | D5 | D4        | D3        | D2        | D1        | D0        |
|------------|-------------|----|----|-----------|-----------|-----------|-----------|-----------|
| Bit Name   | SET_IMOD[0] | X  | X  | MODINC[4] | MODINC[3] | MODINC[2] | MODINC[1] | MODINC[0] |
| Read/Write | R           | X  | X  | R/W       | R/W       | R/W       | R/W       | R/W       |
| POR State  | 0           | X  | X  | 0         | 0         | 0         | 0         | 0         |

The MODINC register increments/decrements the SET\_IMOD register.

| BIT    | NAME        | DESCRIPTION   |
|--------|-------------|---|
| D7     | SET_IMOD[0] | LSB of SET_IMOD register  |
| D[4:0] | MODINC      | This string of bits is used to increment or decrement the modulation current. When written to, the SET_IMOD[8:0] bits are updated. MODINC[4:0] are a two's complement string. |

## 11.3Gbps, Low-Power, DC-Coupled Laser Driver

**DC Current Increment Setting Register (DCINC), Address: H0x0D**

| Bit        | D7           | D6 | D5 | D4         | D3         | D2         | D1         | D0         |
|------------|--------------|----|----|------------|------------|------------|------------|------------|
| Bit Name   | SET_IBIAS[0] | X  | X  | BIASINC[4] | BIASINC[3] | BIASINC[2] | BIASINC[1] | BIASINC[0] |
| Read/Write | R            | X  | X  | R/W        | R/W        | R/W        | R/W        | R/W        |
| POR State  | 0            | X  | X  | 0          | 0          | 0          | 0          | 0          |

The BIASINC register increments/decrements the SET\_IBIAS register.

| BIT    | NAME         | DESCRIPTION   |
|--------|--------------|---|
| D7     | SET_IBIAS[0] | LSB of SET_IBIAS register.  |
| D[4:0] | BIASINC      | This string of bits is used to increment or decrement the modulation current. When written to, the SET_IBIAS[8:0] bits are updated. BIASINC[4:0] are a two's complement string. |

**Mode Control Register (MODECTRL), Address: H0x0E**

| Bit             | D7          | D6          | D5          | D4          | D3          | D2          | D1          | D0          |
|-----------------|-------------|-------------|-------------|-------------|-------------|-------------|-------------|-------------|
| Bit Name        | MODECTRL[7] | MODECTRL[6] | MODECTRL[5] | MODECTRL[4] | MODECTRL[3] | MODECTRL[2] | MODECTRL[1] | MODECTRL[0] |
| Read/Write      | R/W         | R/W         | R/W         | R/W         | R/W         | R/W         | R/W         | R/W         |
| POR State       | 0           | 0           | 0           | 0           | 0           | 0           | 0           | 0           |
| Reset Upon Read | Yes*        | Yes*        | Yes*        | Yes*        | Yes*        | Yes*        | Yes*        | Yes*        |

\*All three modes reset back to 0h on the next 3-wire access.

The MODECTRL register set the operational mode of the 3-wire control for the MAX3948.

| BIT    | NAME          | DESCRIPTION  |
|--------|---------------|--|
| D[7:0] | MODECTRL[7:0] | The MODECTRL register enables the user to switch between normal and setup modes. The setup mode is achieved by setting this register to 12h. MODECTRL must be updated before each write operation. Exceptions are MODINC and DCINC, which can be updated in normal mode.<br>00h: normal mode<br>12h: setup mode<br>C9h: broadcast mode |

## 11.3Gbps, Low-Power, DC-Coupled Laser Driver

**Fault Mask Register (FMSK), Address: H0x0F**

| Bit             | D7 | D6       | D5      | D4      | D3      | D2      | D1      | D0      |
|-----------------|----|----------|---------|---------|---------|---------|---------|---------|
| Bit Name        | X  | RESERVED | FMSK[5] | FMSK[4] | FMSK[3] | FMSK[2] | FMSK[1] | FMSK[0] |
| Read/Write      | X  | R/W      | R/W     | R/W     | R/W     | R/W     | R/W     | R/W     |
| POR State       | X  | 1        | 1       | 0       | 0       | 0       | 0       | 0       |
| Reset Upon Read | X  | No       | No      | No      | No      | No      | No      | No      |

The FMSK register sets masking for the fault circuitry.

| BIT | NAME     | DESCRIPTION   |
|-----|----------|---|
| D6  | RESERVED | Reserved. <b>This bit must be kept at logic 1 for all operations.</b>   |
| D5  | FMSK[5]  | Input LOS FAULT condition mask.<br>0 = No mask<br>1 = Mask  |
| D4  | FMSK[4]  | VOUT too low FAULT condition mask. This condition is intended to behave like a warning/soft fault in normal operation. In normal operation, FMSK[4] should be kept at logic 1.<br>0 = No mask<br>1 = Mask   |
| D3  | FMSK[3]  | TOUTA open or shorted to GND FAULT condition mask.<br>0 = No mask<br>1 = Mask   |
| D2  | FMSK[2]  | TOUTC open or shorted to GND FAULT condition mask.<br>0 = No mask<br>1 = Mask   |
| D1  | FMSK[1]  | VOUT or V <sub>CC</sub> T open or shorted to GND FAULT conditions mask.<br>0 = No mask<br>1 = Mask  |
| D0  | FMSK[0]  | Masks the FAULT latch signal, which controls the output stage on/off behavior.<br>0 = No mask<br>1 = Mask<br>When FMSK[0] = 1, output stage behavior becomes independent of FAULT conditions and is only controlled by DISABLE pin and TX_EN bit. Masking this bit has no impact on normal reporting of fault status bits and assertion of the FAULT pin. |

**11.3Gbps, Low-Power, DC-Coupled Laser Driver****Transmitter Deemphasis Control Register (SET\_TXDE), Address: H0x10**

| Bit        | D7 | D6          | D5          | D4          | D3          | D2          | D1          | D0          |
|------------|----|-------------|-------------|-------------|-------------|-------------|-------------|-------------|
| Bit Name   | X  | SET_TXDE[6] | SET_TXDE[5] | SET_TXDE[4] | SET_TXDE[3] | SET_TXDE[2] | SET_TXDE[1] | SET_TXDE[0] |
| Read/Write | X  | R/W         | R/W         | R/W         | R/W         | R/W         | R/W         | R/W         |
| POR State  | X  | 0           | 0           | 0           | 0           | 0           | 1           | 0           |

The SET\_TXDE register sets the deemphasis amount for the transmitter when TXDE\_MD[1:0] is 10b.

| BIT    | NAME          | DESCRIPTION   |
|--------|---------------|---|
| D[6:0] | SET_TXDE[6:0] | This is a 7-bit register used to control the amount of deemphasis on the transmitter output. When calculating the total modulation current, the amount of deemphasis must be taken into account. Deemphasis is set as a percentage of modulation current. |

**Transmitter Equalization Control Register (SET\_TXEQ), Address: H0x11**

| Bit        | D7 | D6 | D5 | D4 | D3 | D2 | D1          | D0          |
|------------|----|----|----|----|----|----|-------------|-------------|
| Bit Name   | X  | X  | X  | X  | X  | X  | SET_TXEQ[1] | SET_TXEQ[0] |
| Read/Write | X  | X  | X  | X  | X  | X  | R/W         | R/W         |
| POR State  | X  | X  | X  | X  | X  | X  | 0           | 0           |

The SET\_TXEQ register sets the equalization amount for the transmitter input.

| BIT    | NAME     | DESCRIPTION   |
|--------|----------|---|
| D[1:0] | SET_TXEQ | This is a 2-bit register used to control the amount of equalization on the transmitter input. See Table 1 for more information. |

## 11.3Gbps, Low-Power, DC-Coupled Laser Driver

### Design Procedure

#### Programming Modulation Current

- 1)  $IMODMAX[7:0]$  = Maximum\_Modulation\_Current\_Value
- 2)  $SET\_IMOD_n[8:0]$  = Present\_Modulation\_Current\_Value

**Note:**  $SET\_IMOD[8:1]$  are the bits that can be manually written.  $SET\_IMOD[0]$  can only be updated using the  $MODINC$  register.

When implementing modulation current temperature compensation, it is recommended to use the  $MODINC$  register, which guarantees the fastest modulation current update.

- 3)  $MODINC_n[4:0]$  = New\_Increment\_Value

The device performs the following operation when  $MODINC_n[4:0]$  is written to:

If  $(SET\_IMOD_n[8:1] \leq IMODMAX[7:0])$ , then  
 $(SET\_IMOD_n[8:0] = SET\_IMOD_{n-1}[8:0] + MODINC_n[4:0])$   
 else  $(SET\_IMOD_n[8:1] = IMODMAX[7:0])$

The modulation DAC current can be calculated using the following equation:

$$IMOD \text{ DAC Current} = I_{MOD} = (16 + SET\_IMOD[8:0]) \times 247\mu A$$

The net modulation current (P-P) seen at the laser when driven differentially is calculated using the following equation:

$$LD_{MOD} = I_{MOD} \times (1 - DE) \times 50 / (50 + R)$$

where R is the differential load impedance of the laser plus any added series resistance, and DE is the deemphasis factor controlled by the  $TX\_DEMD[1:0]$  bits.

- 4)  $TXCTRL[4:3] = 00$ ,  $DE = 0.0625$  (~ 6% deemphasis case). In this mode, the device calculates and sets  $SET\_TXDE[6:0] = SET\_IMOD[8:2]$ .  $SET\_TXDE$  is not accessible for external write.
- 5)  $TXCTRL[4:3] = 01$ ,  $DE = 0.03125$  (~ 3% deemphasis case). In this mode, the device calculates and sets  $SET\_TXDE[6:0] = SET\_IMOD[8:3]$ .  $SET\_TXDE$  is not accessible for external write.

- 6)  $TXCTRL[4:3] = 10$ ,  $SET\_TXDE$  can be externally set to any value  $\geq SET\_IMOD[8:3]$ :

$$I_{DE} = (2 + SET\_TXDE[6:0]) \times 61.8\mu A$$

In this case  $DE = I_{DE} / I_{MOD}$ . The value of the DE factor starts close to 0.03 and can go up to 0.09 as the value of  $SET\_TXDE[6:0]$  is increased. Once the DE ratio is close to 0.09, the  $I_{DE}$  saturates and a further increase in  $SET\_TXDE[6:0]$  value does not change  $I_{DE}$  much.

- 7)  $TXCTRL[4:3] = 11$ ,  $DE = 0.09$  (~ 9% deemphasis case). In this mode, the device calculates and sets the  $SET\_TXDE[6:0] = 127$ .  $SET\_TXDE$  is not accessible for external write.

#### Programming DC Current

- 1)  $IDCMAX[7:0]$  = Maximum\_DC\_Current\_Value
- 2)  $SET\_IDC_n[8:0]$  = Present\_DC\_Current\_Value

**Note:**  $SET\_IDC[8:1]$  are the bits that can be manually written.  $SET\_IDC[0]$  can only be updated using the  $DCINC$  register.

When implementing laser bias current temperature compensation, it is recommended to use the  $DCINC$  register, which guarantees the fastest modulation current update.

- 3)  $DCINC_n[4:0]$  = New\_Increment\_Value

The device performs the following operation when  $DCINC_n[4:0]$  is written to:

If  $(SET\_IDC_n[8:1] \leq IDCMAX[7:0])$ , then  
 $(SET\_IDC_n[8:0] = SET\_IDC_{n-1}[8:0] + DCINC_n[4:0])$   
 else  $(SET\_IDC_n[8:1] = IDCMAX[7:0])$

The DC DAC current can be calculated using the following equation:

$$DC \text{ DAC Current} = I_{DC} = (16 + SET\_IDC[8:0]) \times 116\mu A$$

The net DC current seen at the laser when driven differentially is calculated using the following equation:

$$LD_{DC} = I_{DC} + I_{MOD} \times (DE + R \times (1 - DE)) / (50 + R) / 2$$

where R is the differential load impedance of the laser plus any added series resistance, DE is the deemphasis factor controlled by the  $TX\_DEMD[1:0]$  bits, and  $I_{MOD}$  is the modulation DAC current.

## 11.3Gbps, Low-Power, DC-Coupled Laser Driver

### Applications Information

#### Laser Safety and IEC 825

Using the MAX3948 laser driver alone does not ensure that a transmitter design is compliant with IEC 825. The entire transmitter circuit and component selections must be considered. Each user must determine the level of

fault tolerance required by the application, recognizing that Maxim products are neither designed nor authorized for use as components in systems intended for surgical implant into the body, for applications intended to support or sustain life, or for any other application in which the failure of a Maxim product could create a situation where personal injury or death could occur.

**Table 7. Register Summary**

| REGISTER FUNCTION/ ADDRESS                       | REGISTER NAME | NORMAL MODE | SETUP MODE | BIT NUMBER/ TYPE | BIT NAME   | DEFAULT VALUE | NOTES   |
|--|---------------|-------------|------------|------------------|------------|---------------|---|
| Transmitter Control Register<br>Address = H0x05  | TXCTRL        | R           | R/W        | 7                | Reserved   | 0             | Must be kept at 0                             |
|  |               | R           | R/W        | 6                | Reserved   | 0             | Must be kept at 0                             |
|  |               | R           | R/W        | 5                | Reserved   | 0             | Must be kept at 0                             |
|  |               | R           | R/W        | 4                | TXDE_MD[1] | 0             | Tx deemphasis control                         |
|  |               | R           | R/W        | 3                | TXDE_MD[0] | 0             | Tx deemphasis control                         |
|  |               | R           | R/W        | 2                | SOFTRES    | 0             | Global digital reset                          |
|  |               | R           | R/W        | 1                | TX_POL     | 1             | Tx polarity<br>0: inverse, 1: normal          |
| Transmitter Status Register 1<br>Address = H0x06 | TXSTAT1       | R           | R          | 7 (sticky)       | FST[7]     | 1             | POR→V <sub>CC</sub> low-limit violation       |
|  |               | R           | R          | 6 (sticky)       | FST[6]     | X             | Reserved                                      |
|  |               | R           | R          | 5 (sticky)       | FST[5]     | X             | Low or no AC signal at input                  |
|  |               | R           | R          | 4 (sticky)       | FST[4]     | X             | VOUT too low                                  |
|  |               | R           | R          | 3 (sticky)       | FST[3]     | X             | TOUTA open or shorted to GND                  |
|  |               | R           | R          | 2 (sticky)       | FST[2]     | X             | TOUTC open or shorted to GND                  |
|  |               | R           | R          | 1 (sticky)       | FST[1]     | X             | VOUT/V <sub>CC</sub> T open or shorted to GND |
|  |               | R           | R          | 0 (sticky)       | FST[0]     | X             | Copy of FAULT signal                          |

## 11.3Gbps, Low-Power, DC-Coupled Laser Driver

**Table 7. Register Summary (continued)**

| REGISTER FUNCTION/ ADDRESS                                     | REGISTER NAME | NORMAL MODE | SETUP MODE | BIT NUMBER/ TYPE | BIT NAME             | DEFAULT VALUE | NOTES  |
|--|---------------|-------------|------------|------------------|----------------------|---------------|--|
| Transmitter Status Register 2<br>Address = H0x07               | TXSTAT2       | R           | R          | 3 (sticky)       | IMODERR              | 0             | Modulation current overflow (on increment) or underflow (on decrement) error. Overflow occurs if result > IMODMAX. Underflow occurs if result < 0. |
|  |               | R           | R          | 2 (sticky)       | IDCERR               | 0             | DC current overflow (on increment) or underflow (on decrement) error. Overflow occurs if result > IDCMAX. Underflow occurs if result < 0.          |
| DC Current Setting Register<br>Address = H0x08                 | SET_IDC       | R           | R/W        | 7                | SET_IDC[8]           | 0             | MSB DC DAC   |
|  |               | R           | R/W        | 6                | SET_IDC[7]           | 0             |  |
|  |               | R           | R/W        | 5                | SET_IDC[6]           | 0             |  |
|  |               | R           | R/W        | 4                | SET_IDC[5]           | 0             |  |
|  |               | R           | R/W        | 3                | SET_IDC[4]           | 0             |  |
|  |               | R           | R/W        | 2                | SET_IDC[3]           | 0             |  |
|  |               | R           | R/W        | 1                | SET_IDC[2]           | 0             |  |
| Modulation Current Setting Register<br>Address = H0x09         | SET_IMOD      | R           | R/W        | 7                | SET_IMOD[8]          | 0             | MSB modulation DAC   |
|  |               | R           | R/W        | 6                | SET_IMOD[7]          | 0             |  |
|  |               | R           | R/W        | 5                | SET_IMOD[6]          | 0             |  |
|  |               | R           | R/W        | 4                | SET_IMOD[5]          | 0             |  |
|  |               | R           | R/W        | 3                | SET_IMOD[4]          | 0             |  |
|  |               | R           | R/W        | 2                | SET_IMOD[3]          | 1             |  |
|  |               | R           | R/W        | 1                | SET_IMOD[2]          | 0             |  |
| Maximum Modulation Current Setting Register<br>Address = H0x0A | IMODMAX       | R           | R/W        | 7                | IMODMAX[7]           | 0             | MSB modulation limit   |
|  |               | R           | R/W        | 6                | IMODMAX[6]           | 0             |  |
|  |               | R           | R/W        | 5                | IMODMAX[5]           | 1             |  |
|  |               | R           | R/W        | 4                | IMODMAX[4]           | 0             |  |
|  |               | R           | R/W        | 3                | IMODMAX[3]           | 0             |  |
|  |               | R           | R/W        | 2                | IMODMAX[2]           | 0             |  |
|  |               | R           | R/W        | 1                | IMODMAX[1]           | 0             |  |
| R  | R/W           | 0           | IMODMAX[0] | 0                | LSB modulation limit |               |  |

## 11.3Gbps, Low-Power, DC-Coupled Laser Driver

**Table 7. Register Summary (continued)**

| REGISTER FUNCTION/ ADDRESS  | REGISTER NAME | NORMAL MODE | SETUP MODE  | BIT NUMBER/ TYPE | BIT NAME         | DEFAULT VALUE | NOTES   |
|---|---------------|-------------|-------------|------------------|------------------|---------------|---|
| Maximum DC DAC Current Setting Register<br><b>Address = H0x0B</b>       | IDCMAX        | R           | R/W         | 7                | IDCMAX[7]        | 0             | MSB DC DAC limit                                |
|   |               | R           | R/W         | 6                | IDCMAX[6]        | 0             |   |
|   |               | R           | R/W         | 5                | IDCMAX[5]        | 1             |   |
|   |               | R           | R/W         | 4                | IDCMAX[4]        | 0             |   |
|   |               | R           | R/W         | 3                | IDCMAX[3]        | 0             |   |
|   |               | R           | R/W         | 2                | IDCMAX[2]        | 0             |   |
|   |               | R           | R/W         | 1                | IDCMAX[1]        | 0             |   |
| Modulation Current Increment Setting Register<br><b>Address = H0x0C</b> | MODINC        | R           | R           | 7                | SET_IMOD[0]      | 0             | LSB of SET_IMOD DAC register address = H0x09    |
|   |               | R/W         | R/W         | 4                | MODINC[4]        | 0             | MSB MOD DAC two's complement                    |
|   |               | R/W         | R/W         | 3                | MODINC[3]        | 0             |   |
|   |               | R/W         | R/W         | 2                | MODINC[2]        | 0             |   |
|   |               | R/W         | R/W         | 1                | MODINC[1]        | 0             |   |
| DC Current Increment Setting Register<br><b>Address = H0x0D</b>         | DCINC         | R           | R           | 7                | SET_IDC[0]       | 0             | LSB of SET_IDC DAC register address = H0x08     |
|   |               | R/W         | R/W         | 4                | DCINC[4]         | 0             | MSB DC DAC two's complement increment/decrement |
|   |               | R/W         | R/W         | 3                | DCINC[3]         | 0             |   |
|   |               | R/W         | R/W         | 2                | DCINC[2]         | 0             |   |
|   |               | R/W         | R/W         | 1                | DCINC[1]         | 0             |   |
| Mode Control Register<br><b>Address = H0x0E</b>                         | MODECTRL      | R/W         | R/W         | 7                | MODECTRL[7]      | 0             | MSB mode control                                |
|   |               | R/W         | R/W         | 6                | MODECTRL[6]      | 0             |   |
|   |               | R/W         | R/W         | 5                | MODECTRL[5]      | 0             |   |
|   |               | R/W         | R/W         | 4                | MODECTRL[4]      | 0             |   |
|   |               | R/W         | R/W         | 3                | MODECTRL[3]      | 0             |   |
|   |               | R/W         | R/W         | 2                | MODECTRL[2]      | 0             |   |
|   |               | R/W         | R/W         | 1                | MODECTRL[1]      | 0             |   |
| R/W   | R/W           | 0           | MODECTRL[0] | 0                | LSB mode control |               |   |



## 11.3Gbps, Low-Power, DC-Coupled Laser Driver

**Table 7. Register Summary (continued)**

| REGISTER FUNCTION/ ADDRESS  | REGISTER NAME | NORMAL MODE | SETUP MODE | BIT NUMBER/ TYPE | BIT NAME    | DEFAULT VALUE | NOTES                   |
|---|---------------|-------------|------------|------------------|-------------|---------------|-------------------------|
| Fault Mask Register<br><b>Address = H0x0F</b>                       | FMSK          | R           | R/W        | 6                | RESERVED    | 1             | Must be kept at logic 1 |
|   |               | R           | R/W        | 5                | FMSK[5]     | 1             | MSB Tx fault mask       |
|   |               | R           | R/W        | 4                | FMSK[4]     | 0             |                         |
|   |               | R           | R/W        | 3                | FMSK[3]     | 0             |                         |
|   |               | R           | R/W        | 2                | FMSK[2]     | 0             |                         |
|   |               | R           | R/W        | 0                | FMSK[0]     | 0             | LSB Tx fault mask       |
| Transmitter Deemphasis Control Register<br><b>Address = H0x10</b>   | SET_TXDE      | R           | R/W        | 6                | SET_TXDE[6] | 0             | MSB Tx deemphasis       |
|   |               | R           | R/W        | 5                | SET_TXDE[5] | 0             |                         |
|   |               | R           | R/W        | 4                | SET_TXDE[4] | 0             |                         |
|   |               | R           | R/W        | 3                | SET_TXDE[3] | 0             |                         |
|   |               | R           | R/W        | 2                | SET_TXDE[2] | 0             |                         |
|   |               | R           | R/W        | 0                | SET_TXDE[0] | 0             | LSB Tx deemphasis       |
| Transmitter Equalization Control Register<br><b>Address = H0x11</b> | SET_TXEQ      | R           | R/W        | 1                | SET_TXEQ[1] | 0             | Tx equalization control |
|   |               | R           | R/W        | 0                | SET_TXEQ[0] | 0             | Tx equalization control |

### Layout Considerations

The data inputs and outputs are the most critical paths for the MAX3948 and great care should be taken to minimize discontinuities on these transmission lines. The following are some suggestions for maximizing the performance of the IC:

- Use good high-frequency layout techniques and multilayer boards with an uninterrupted ground plane to minimize EMI and crosstalk.
- The data inputs should be wired directly between the module connector and IC without stubs.
- Maintain 100Ω differential transmission line impedance into the IC.
- The data transmission lines to the laser should be kept as short as possible, and must be designed for 50Ω differential or 25Ω single-ended characteristic impedance.

- An uninterrupted ground plane should be positioned beneath the high-speed I/Os.
- Ground path vias should be placed close to the IC and the input/output interfaces to allow a return current path to the IC and the laser.

Refer to the schematic and board layers of MAX3948 Evaluation Kit for more information.

### Exposed-Pad Package and Thermal Considerations

The exposed pad on the 16-pin TQFN package provides a very low-thermal resistance path for heat removal from the IC. The pad is the only electrical ground on the MAX3948 and must be soldered to the circuit board ground for proper thermal and electrical performance. Refer to [Application Note 862: HFAN-08.1: Thermal Considerations for QFN and Other Exposed-Paddle Packages](#) for additional information.

# MAX3948

## 11.3Gbps, Low-Power, DC-Coupled Laser Driver

### Typical Application Circuits

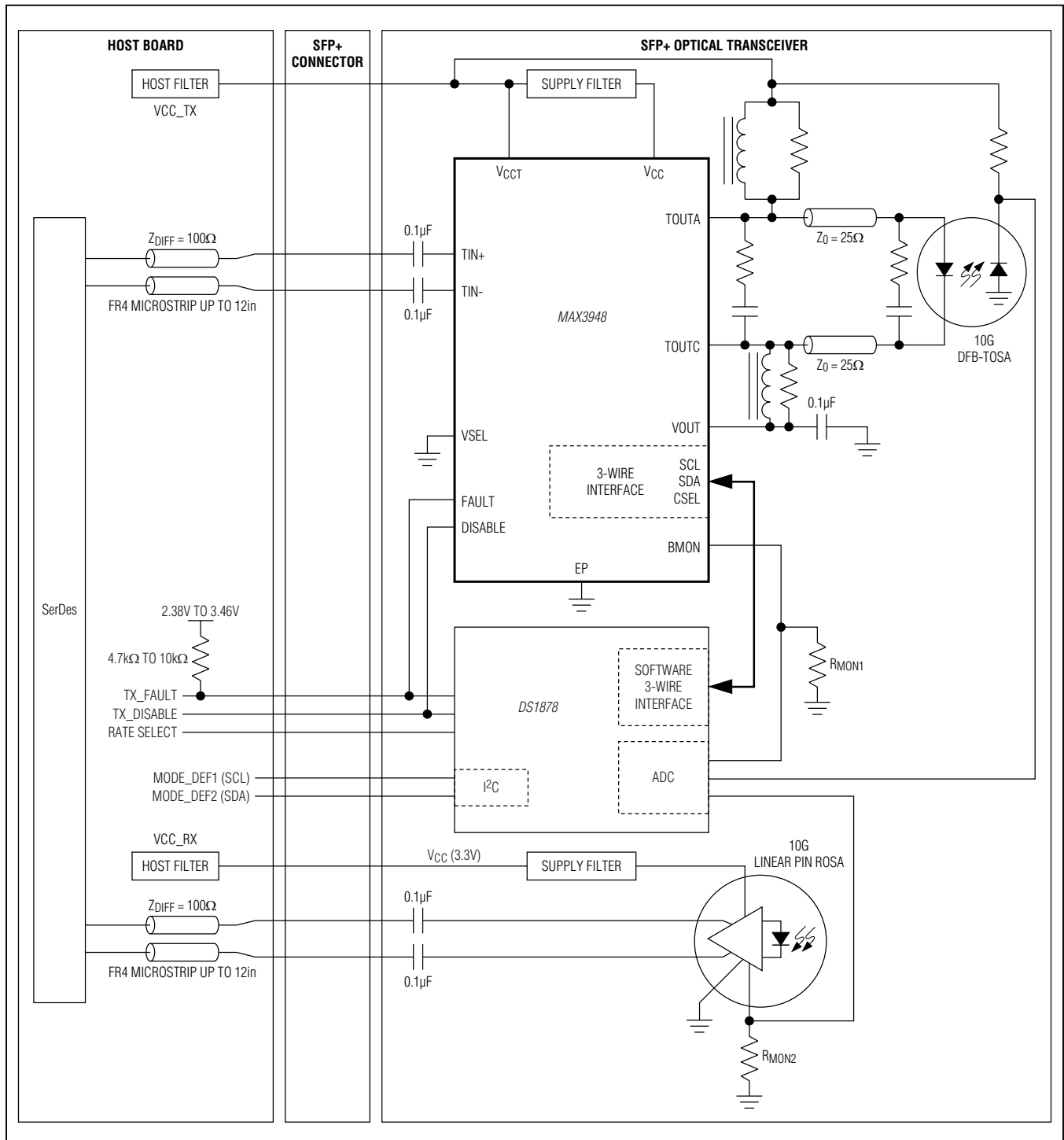

# MAX3948

## 11.3Gbps, Low-Power, DC-Coupled Laser Driver

### Typical Application Circuits (continued)

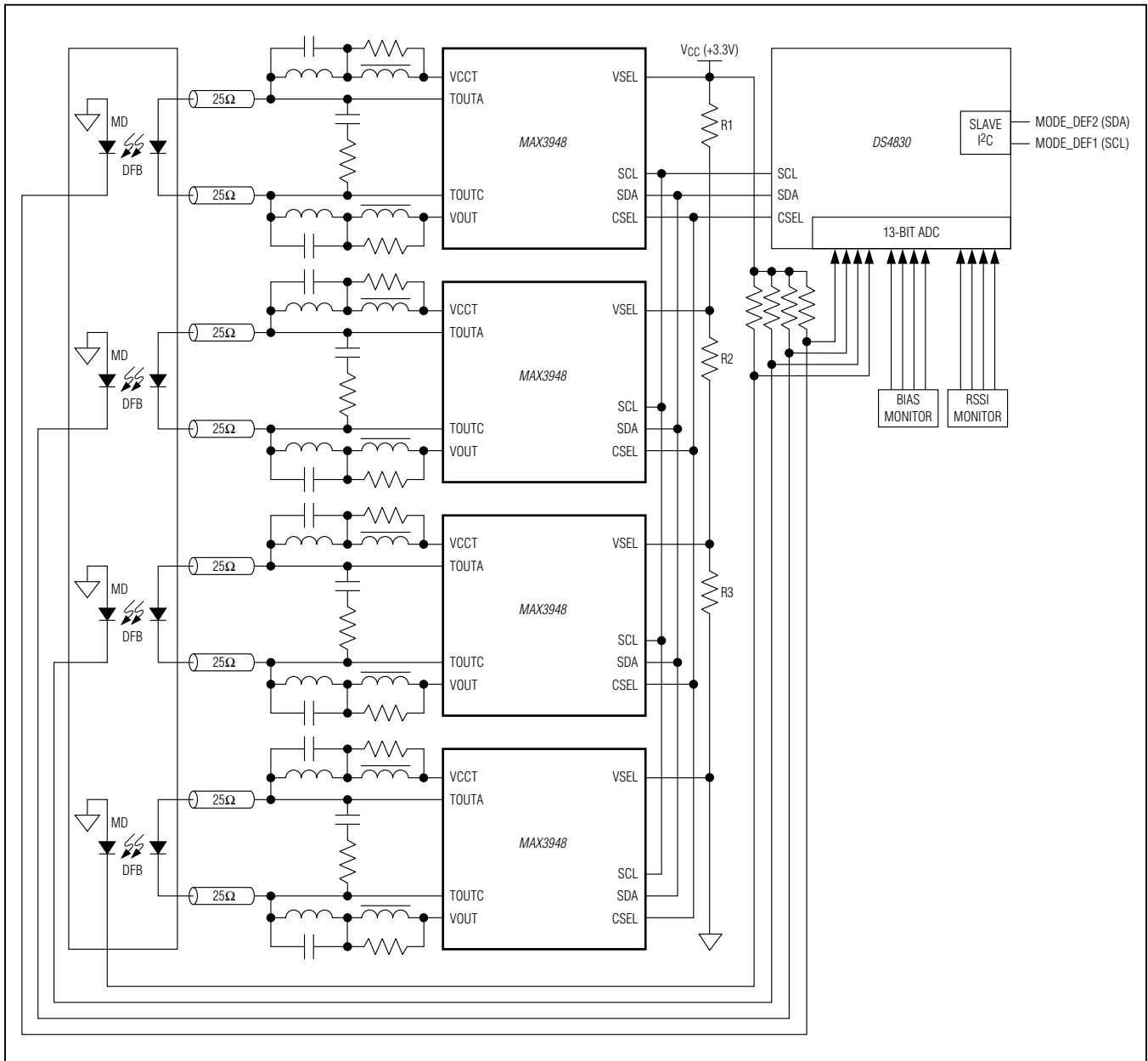

## 11.3Gbps, Low-Power, DC-Coupled Laser Driver

### Ordering Information

| PART        | TEMP RANGE     | PIN-PACKAGE |
|-------------|----------------|-------------|
| MAX3948ETE+ | -40°C to +85°C | 16 TQFN-EP* |

**Note:** Parts are guaranteed by design and characterization to operate over the -40°C to +95°C ambient temperature range ( $T_A$ ) and are tested up to +85°C.

+Denotes a lead(Pb)-free/RoHS-compliant package.

\*Exposed pad.

### Chip Information

PROCESS: SiGe BiPOLAR

### Package Information

For the latest package outline information and land patterns (footprints), go to [www.maximintegrated.com/packages](http://www.maximintegrated.com/packages). Note that a "+", "#", or "-" in the package code indicates RoHS status only. Package drawings may show a different suffix character, but the drawing pertains to the package regardless of RoHS status.

| PACKAGE TYPE | PACKAGE CODE | OUTLINE NO.             | LAND PATTERN NO.        |
|--------------|--------------|-------------------------|-------------------------|
| 16 TQFN-EP   | T1633+5      | <a href="#">21-0136</a> | <a href="#">90-0032</a> |

# MAX3948

## 11.3Gbps, Low-Power, DC-Coupled Laser Driver

### Revision History

| REVISION NUMBER | REVISION DATE | DESCRIPTION   | PAGES CHANGED |
|-----------------|---------------|---|---------------|
| 0               | 6/11          | Initial release   | —             |
| 1               | 6/12          | Updated step 5 in the <i>Programming Modulation Current</i> section; updated <i>Typical Application Circuit</i> | 29, 34        |



Maxim Integrated cannot assume responsibility for use of any circuitry other than circuitry entirely embodied in a Maxim Integrated product. No circuit patent licenses are implied. Maxim Integrated reserves the right to change the circuitry and specifications without notice at any time. The parametric values (min and max limits) shown in the Electrical Characteristics table are guaranteed. Other parametric values quoted in this data sheet are provided for guidance.

**Maxim Integrated 160 Rio Robles, San Jose, CA 95134 USA 1-408-601-1000**

37