

1. THIS RECEPTACLE WILL MATE WITH ANY 26 POSN, SIZE 2 PLUG IN AMPLIMITE SERIES.
  2. BE-CU RETENTION CLIPS ARE INCLUDED IN INSERT AND INSTALLED WITH TINES POINTING TOWARDS MATING FACE.
  3. CONNECTOR SUPPLIED WITHOUT CONTACTS, SHOWN FOR ILLUSTRATION ONLY. SEE NOTE 6.
  4. OVERALL DIMENSIONS DO NOT INCLUDE RAISED CAVITY IDENTIFICATION.
- △ MARKING FAR SIDE REFERS TO WIDE SIDE OF KEYSTONE. NEAR SIDE REFERS TO NARROW SIDE OF KEYSTONE
- △ SOCKET CONTACT (QTY=26) INCLUDED IN KIT. (-7 ONLY)
- △ 100% INSPECTION REQUIRED PER BOEING 1B01:  
 A. VISUAL  
 B. DWV  
 C. IR
- △ CUSTOMER REQUIRES SINGLE LOT DATE CODE.
- △ SPECIAL REQUIREMENTS:  
 A. TEST TWO CONNECTORS PER LOT FOR COMPLIANCE TO GROMMET PEEL STRENGTH REQUIREMENTS.  
 B. TEST ALL CIRCUIT CAVITIES FOR MISALIGNMENT OR EXCESSIVE ADHESIVE.

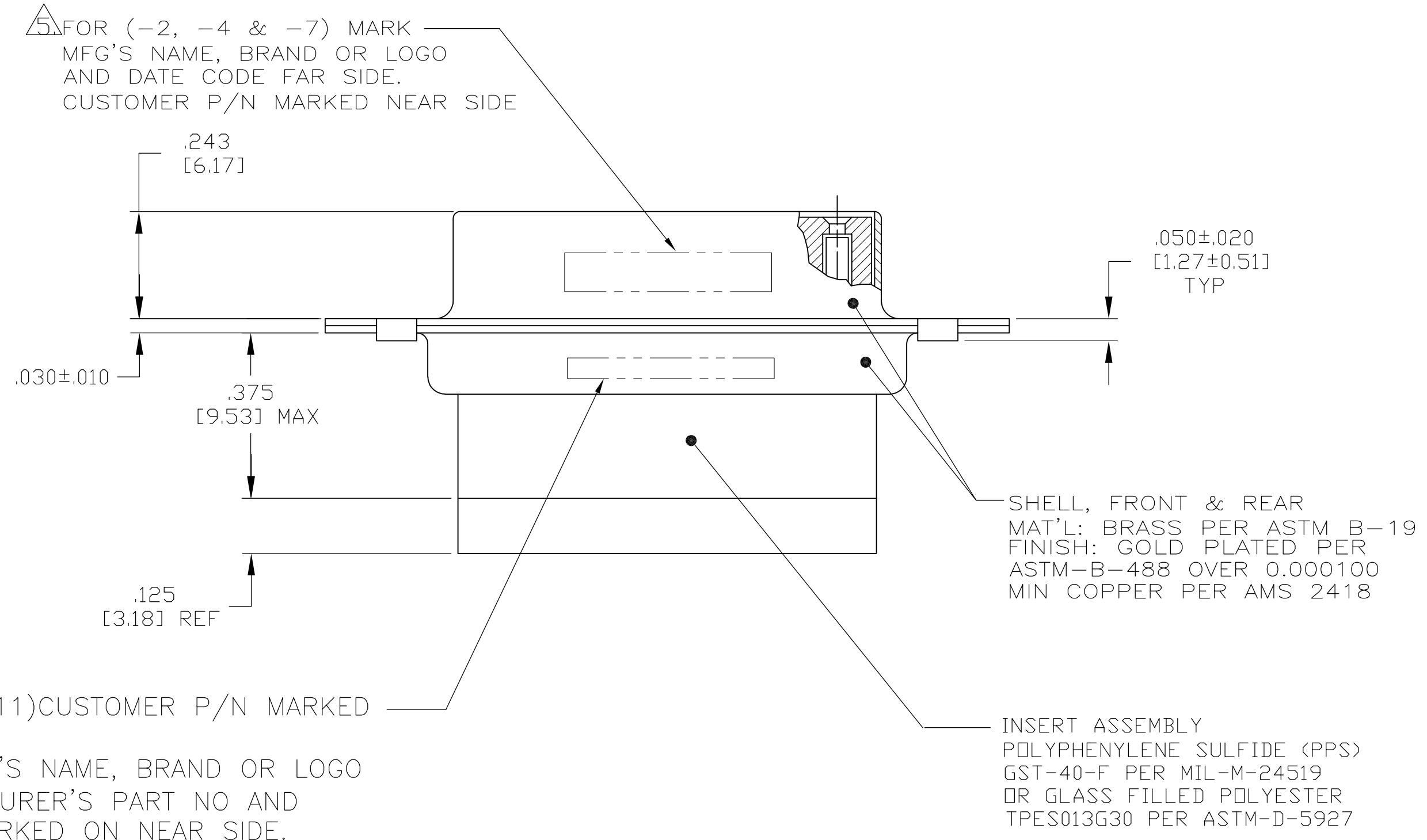

△ FOR (-1 & -11) CUSTOMER P/N MARKED ON FAR SIDE.  
 MANUFACTURER'S NAME, BRAND OR LOGO AND MANUFACTURER'S PART NO AND DATE CODE MARKED ON NEAR SIDE.  
 FOR (-2, -4 & -7) MARK MFG'S P/N FAR SIDE.

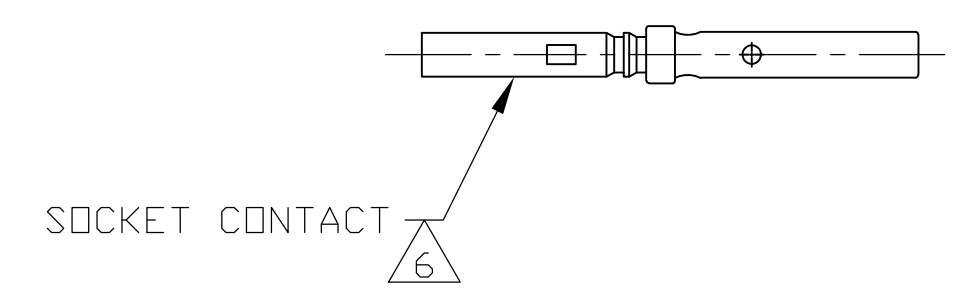
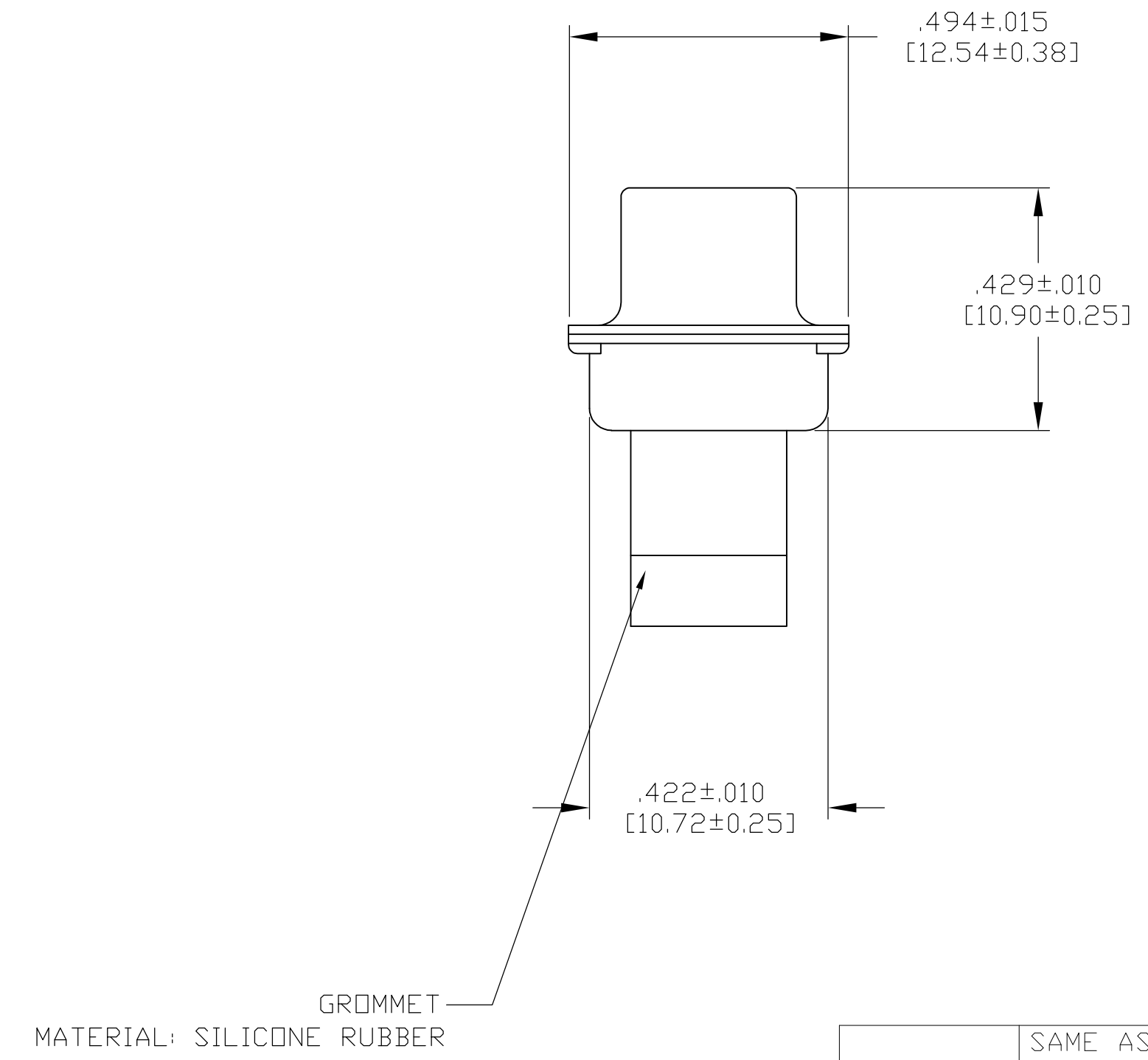

REMARKS	DESCRIPTION	PART NO
-	SAME AS -1 EXCEPT CUSTOMER PART NO. 1B01-026RHW MARKED	1-211668-1
△	SAME AS -1 EXCEPT FORD PART NO. B010648-0004 MARKED	211668-7
-	SAME AS -1 EXCEPT NO CUSTOMER PART NO MARKED	211668-4
-	SAME AS -1 EXCEPT WITH TRW PART NUMBER 2A065-020V-001 MARKED AS SHOWN-WITH HUGHES PART NO 1B01-026 MARKED	211668-2
-		211668-1

THIS DRAWING IS A CONTROLLED DOCUMENT.

DWY	P. YEAGER	26JUN06	Tyco Electronics Corporation Harrisburg, PA 17105-3608
CHK	D. MILLER	30JUN06	
APP'D	D. MILLER	30JUN06	NAME RECEPTACLE ASSEMBLY, AMPLIMITE 26 POSITION, SIZE 2, SERIES 90, NON-MAGNETIC, SPECIAL WITH GROMMET
PRODUCT SPEC			
APPLICATION SPEC			SIZE A1
MATERIAL SEE CALLOUTS	FINISH SEE CALLOUTS	WEIGHT -	CAGE CODE 00779
CUSTOMER DRAWING		SCALE 4:1	SHEET 1 OF 1

RESTRICTED TO REV K