

THIS DRAWING IS UNPUBLISHED. RELEASED FOR PUBLICATION JUL, 1996.
 © COPYRIGHT 1996 BY TYCO ELECTRONICS CORPORATION. ALL INTERNATIONAL RIGHTS RESERVED.

LOC	DIST	REVISIONS 変更					
J	/	P	LTR	DESCRIPTION	DATE	DWN	APVD
		B		REDRAWN AND REVISED ECR-10-023816	26NOV2010	T.T	T.M

表1 TABLE 1

トレードマーク TRADE MARK	生産場所 MANUFACTURING LOCATION
AMP	シンガポール SINGAPORE
TE	中国 CHINA

-1, -2; AS SHOWN

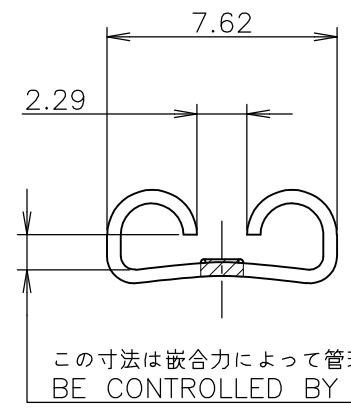
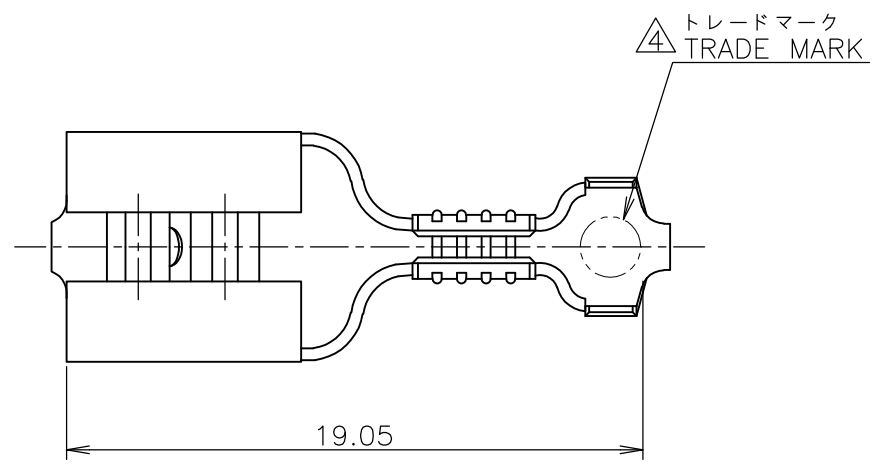

VIEW A-A
矢視

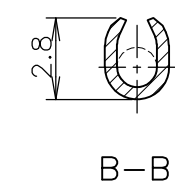
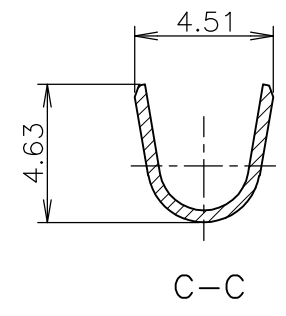
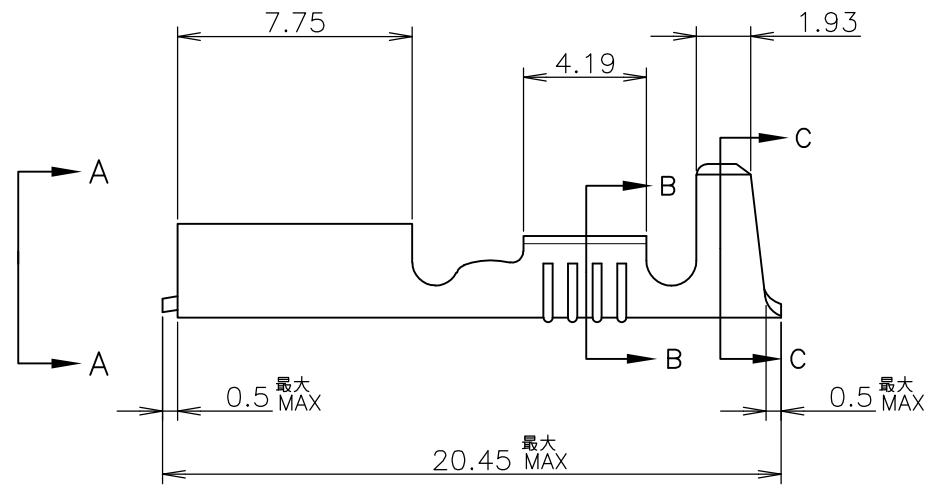

- 1 嵌合するファストンタブの詳細については#CP63-048Jの図面を参照の事
- 2 170187は170183のワイヤバレルをプリフォミングしたもののルーズピースである。
- 3 ストレス除去処理
処理法により外観が変わります。
不活性ガス加熱方式・・・無光沢
大気加熱方式・・・・・・・・光沢
- 4 表1参照

108-5178	TIN PLT 錫めっき	170183-2	BRASS 0.41 THK 黄銅 板厚 0.41	170187-2
108-5006	—H— ③	170183-1	BRASS 0.41 THK 黄銅 板厚 0.41	170187-1
PRODUCT SPEC 製品規格	FINISH 仕上	ST NO. ST型番	MATERIAL 材質	P/N 型番

WIRE RANGE
抱合電線断面積 AWG #22-#18
0.30~0.89 mm²

INSULATION DIA
被覆外径 (.090-.130IN)
2.29~33 mm ϕ

- 1 SEE DWG CP63-048J FOR THE DETAIL OF MATING TAB
- 2 170187 IS LOOSE PIECE OF PREFORMED WIRE BARREL 170183
- 3 STRESS RELIEVING
FINISH IS SUBJECT TO CHANGE BY THE TYPE OF
STRESS RELIEVING PROCESS
INERT GAS FURNACE-----MATTE
ATMOSPHERIC FURNACE FOLLOWED BY ACID PICKLE---BRIGHT
- 4 SEE TABLE 1

THIS DRAWING IS A CONTROLLED DOCUMENT.		DWN T.TSUZAKI 24NOV2010	Tyco Electronics Corporation Tyco Electronics Kawasaki, Japan	
DIMENSIONS: 単位: 耗 mm		CHK T.MASUDA 26NOV2010	NAME 名称 250 SERIES FASTON RECEPTACLE LOOSE PIECE 250 シリーズ ファストン リセプタクル L.P.	
TOLERANCES UNLESS OTHERWISE SPECIFIED: 一般公差		APVD T.MASUDA 26NOV2010	PRODUCT SPEC 製品規格 表参照 SEE TABLE	
0-PLC ± 1-PLC ± 2-PLC ± 3-PLC ± 4-PLC ± ANGLES ±1°		APPLICATION SPEC 取付適用規格 114-5084	RESTRICTED TO —	
MATERIAL 材料 表参照 SEE TABLE	FINISH 仕上 表参照 SEE TABLE	WEIGHT	SIZE A3	CAGE CODE 00779
CUSTOMER DRAWING			DRAWING NO 番号 G-170187	SCALE 尺度 4:1
			SHEET 1 OF 1	REV B