

IC1206B153R-10

UNCONTROLLED DOCUMENT

PHYSICAL DIMENSIONS:

A	3.20 [.126]	+ 0.20[.008]
B	1.60 [.063]	+ 0.20[.008]
C	1.10 [.043]	+ 0.30[.012]
D	0.50 [.020]	+ 0.30[.012]

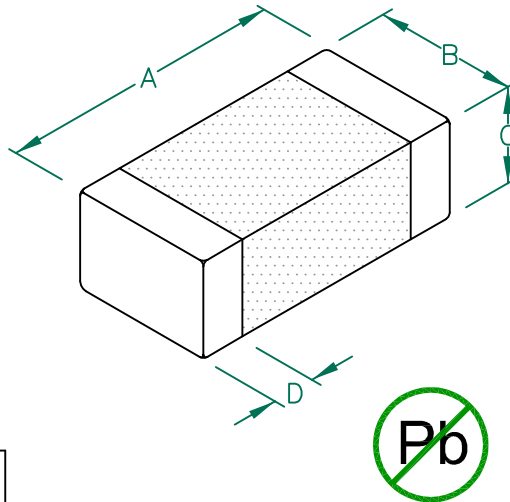

- NOTES: UNLESS OTHERWISE SPECIFIED
1. TAPED AND REELED per CURRENT EIA SPECIFICATIONS 7" REELS, 3000 PCS/REEL, EMBOSSED PLASTIC TAPE.
 2. TERMINATION FINISH IS 100% MATTE Sn OVER Ni.
 3. COMPONENTS SHOULD BE ADEQUATELY PREHEATED BEFORE SOLDERING.
 4. I (MAX.) IS BASED ON THE MAXIMUM SUSTAINED CURRENT APPLIED WHILE MAINTAINING A MAXIMUM TEMPERATURE RISE OF 40°C OVER AMBIENT.
 5. I (OPERATING) IS BASED ON THE MAXIMUM SUSTAINED CURRENT APPLIED WHILE MAINTAINING A MINIMUM INDUCTANCE (L).
 6. OPERATING TEMP. RANGE: -40°C~+125°C. (INCLUDING SELF-HEATING)

ELECTRICAL CHARACTERISTICS:

L (nH) ± 10%	16,500	Max
	15,000	Nom
	13,500	Min@5mA
Q (Min)	35	
Freq. (MHz)	1	
Self-Resonant Freq (MHz)	19	
DCR(Max) Ω	0.70	
I (Max)	200mA	
I (Operating)	5mA	

LAND PATTERNS FOR REFLOW SOLDERING

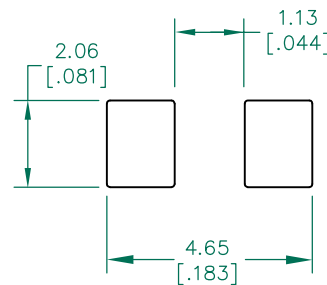

(For wave soldering, add 0.762 (0.030) to this dimension)

RECOMMENDED SOLDERING CONDITIONS

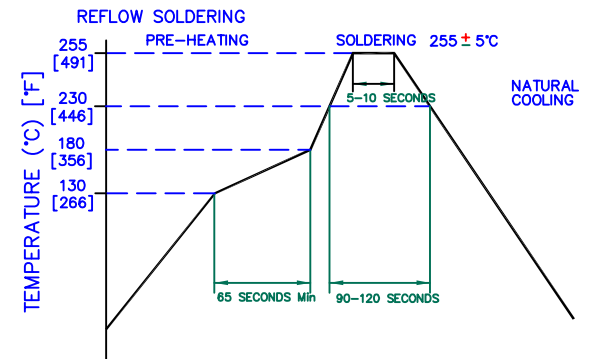

DIMENSIONS ARE IN mm [INCHES].				This print is the property of Laird Tech. and is loaned in confidence subject to return upon request and with the understanding that no copies shall be made without the written consent of Laird Tech. All rights to design or invention are reserved.			
E	ADD OPERATING TEMPERATURE UPDATE LAIRD LOGO AND REFLOW CURVE	08/05/13	QU				
D	UPDATE COMPANY LOGO	06/26/08	JRK				
C	MODIFY NOTES, CHANGE TOLS ON C DIMS CHG ELECT VALUES CHG D DIMS & TOLS	01/18/07	JRK				
B	CHG P/N ADD 5mA TO ELECT BOX REV LANDPATTERN DIMS ADD NOTES	11/23/05	JRK				
A	ORIGINAL DRAFT	6/04/04	JRK				
REV	DESCRIPTION	DATE	INT	PROJECT/PART NUMBER: IC1206B153R-10	REV: E	PART TYPE: CO-FIRE	DRAWN BY: JRK
DATE: 06/04/04				SCALE: NTS	SHEET: 2 of 2		
CAD # IC1206B153R-10-E				TOOL # -			