



PRODUCT SPECIFICATION

0.4mm PITCH, TYPE D, MICRO HDMI CONNECTOR

1.0 SCOPE

This Product Specification covers the 0.40 mm (.016 inch) centerline (pitch) printed circuit board (PCB) connector series with selective gold and tin plating.

2.0 PRODUCT DESCRIPTION

2.1 PRODUCT NAME AND SERIES NUMBER(S)

Receptacle Assembly: Top Mount / Bottom Mount : 46765
Receptacle Assembly: Mid Mount / Offset Mid Mount Thru Hole: 46875 / 78580 / 78592 / 78587 & 78618.

Plug Assembly : 46770

DIMENSIONS, MATERIALS, PLATINGS AND MARKINGS

See the appropriate sales drawings for information on dimensions, materials, plating and markings.

2.2 SAFETY AGENCY APPROVALS

UL File Number..... TBA
CSA File Number..... TBA

3.0 APPLICABLE DOCUMENTS AND SPECIFICATIONS

EIA 364-1000
IEC 801

4.0 RATINGS

4.1 VOLTAGE

30 V

4.2 CURRENT

0.8 Amps @ 25°C

4.3 TEMPERATURE

Operating: - 30°C to + 85°C
Storage: - 40°C to + 85°C

REVISION: 9	ECR/ECN INFORMATION: EC No: S2011-0455 DATE: 2010/11/19	TITLE: PRODUCT SPECIFICATION FOR 0.4mm PITCH, TYPE D MICRO HDMI CONNECTOR	SHEET No. 1 of 9
DOCUMENT NUMBER: PS-46765-003	CREATED / REVISED BY: SHANTH 2010/11/18	CHECKED BY: JESSIE 2010/11/18	APPROVED BY: NAGESH 2010/11/18



PRODUCT SPECIFICATION

5.0 PERFORMANCE REQUIREMENTS

5.1 ELECTRICAL REQUIREMENTS

ITEM	DESCRIPTION	TEST CONDITION	REQUIREMENT
1a	Contact Resistance (Contacts)	Mated connectors Contact: Measure by dry circuit and apply a maximum voltage of 20 mV and a current of 10 mA . (Tested per EIA-364-06B)	Contact: 10 milliohms MAXIMUM [initial] (After Subtracting Bulk resistances of Plug, Receptacle and their PCB traces).
1b	Contact Resistance (Shield)	Mated Connectors Shell: Measure by open circuit and apply a maximum voltage of 5 V and a current of 100 mA . (Tested per EIA-364-06B)	Shell: 10 milliohms MAXIMUM [initial]
2	Insulation Resistance	Unmated connectors Apply a voltage of 500 VDC between adjacent terminals or ground.	100 Megohms MINIMUM (unmated)
		Mated connectors Apply a voltage of 150 VDC between adjacent terminals or ground. Tested per EIA-364-21C	10 Megohms MINIMUM (mated)
3	Dielectric Withstanding Voltage	Unmated connectors Apply a voltage of 250 VAC (RMS) for 1 minute between adjacent terminals or ground Mated connectors Apply a voltage of 150 VAC (RMS) for 1 minute between adjacent terminals or ground Tested per EIA-364-20C, Method A	No breakdown; current leakage < 1 mA
4	Contact Current Rating	Test performed with all 19 Circuits Powered 55°C maximum ambient 85°C maximum temperature change Tested per EIA-364-70A	0.3 A minimum
5	Applied Voltage Rating	40 VAC (RMS) continuous maximum on any signal pin with respect to the shield.	No breakdown; current leakage < 1 mA

REVISION: 9	ECR/ECN INFORMATION: EC No: S2011-0455 DATE: 2010/11/19	TITLE: PRODUCT SPECIFICATION FOR 0.4mm PITCH, TYPE D MICRO HDMI CONNECTOR	SHEET No. 2 of 9
DOCUMENT NUMBER: PS-46765-003	CREATED / REVISED BY: SHANTH 2010/11/18	CHECKED BY: JESSIE 2010/11/18	APPROVED BY: NAGESH 2010/11/18



PRODUCT SPECIFICATION

6	Electrostatic Discharge	Test unmated connectors from 1kV to 8kV in 1kV steps using an 8mm ball probe. Tested per IEC-801-2	No discharge to contacts at 8kV
----------	--------------------------------	--	--

5.1 ELECTRICAL REQUIREMENTS (continued):

ITEM	DESCRIPTION	TEST CONDITION	REQUIREMENT
7	TMDS Signals Time Domain Impedance	Rise Time \leq 200ps (10%-90%). Signal to Ground pin ratio per HDMI designation. Differential Measurement Specimen Environment Impedance = 100 Ohm differential Source-side receptacle connector mounted on a controlled impedance PCB fixture. Tested per EIA-364-108	Connector 100 Ohm \pm 25% Transition Area 100 Ohm \pm 15% Cable Area 100 Ohm \pm 10%
8	TMDS Signals Time Domain Cross Talk (FEXT)	Rise Time \leq 200ps (10%-90%). Signal to Ground pin ratio per HDMI designation. Differential Measurement Specimen Environment Impedance = 100 Ohm differential Source-side receptacle connector mounted on a controlled impedance PCB fixture. Tested per EIA-364-90	10% MAXIMUM

REVISION: 9	ECR/ECN INFORMATION: EC No: S2011-0455 DATE: 2010/11/19	TITLE: PRODUCT SPECIFICATION FOR 0.4mm PITCH, TYPE D MICRO HDMI CONNECTOR	SHEET No. 3 of 9
DOCUMENT NUMBER: PS-46765-003	CREATED / REVISED BY: SHANTH 2010/11/18	CHECKED BY: JESSIE 2010/11/18	APPROVED BY: NAGESH 2010/11/18



PRODUCT SPECIFICATION

5.2 MECHANICAL REQUIREMENTS

ITEM	DESCRIPTION	TEST CONDITION	REQUIREMENT
9	Insertion Force	Mate and unmate connector at a rate of 25 ± 6 mm (1 ± ¼ inch) per minute. Tested per EIA-364-13	44.1 N (10 lbf) MAXIMUM insertion force
10a	Withdrawal Force (Initial)	Mate and unmate connector at a rate of 25 ± 6 mm (1 ± ¼ inch) per minute. Tested per EIA-364-13	5 N (1.1 lbf) MINIMUM 25 N (5.6 lbf) MAXIMUM
10b	Withdrawal Force (After Durability)	Mate and unmate connector for 5,000 cycles at a rate of 25 ± 6 mm (1 ± ¼ inch) per minute. Tested per EIA-364-13	3 N (0.65 lbf) MINIMUM 25 N (5.6 lbf) MAXIMUM
11	Durability	Mate connectors 5,000 cycles at a maximum rate of 100 ± 50 cycles per hour.	Contact: 30 milliohms MAXIMUM (change from initial) & Shell: 50 milliohms MAXIMUM (change from initial)
12	Vibration	Amplitude: 1.52mm P-P or 147m/s² (15G) . Sweep Time: 10-2000-10Hz in 20 minutes. Duration: 12 times in each X,Y,Z axis. Electrical Load: 100mA DC current applied during test. Tested per EIA-364-28, Condition III	Contact: 30 milliohms MAXIMUM (change from initial) & Shell: 50 milliohms MAXIMUM (change from initial) & Discontinuity < 1 microsecond
13	Shock (Mechanical)	Pulse Width: 11msec Waveform: half sine Mate connectors and shock at 490m/s² (50 G) in each of the X,Y,Z axis (3 shocks in each axes) Tested per EIA-134-27, Condition A	Contact: 30 milliohms MAXIMUM (change from initial) & Shell: 50 milliohms MAXIMUM (change from initial) & Discontinuity < 1 microsecond

REVISION: 9	ECR/ECN INFORMATION: EC No: S2011-0455 DATE: 2010/11/19	TITLE: PRODUCT SPECIFICATION FOR 0.4mm PITCH, TYPE D MICRO HDMI CONNECTOR	SHEET No. 4 of 9
DOCUMENT NUMBER: PS-46765-003	CREATED / REVISED BY: SHANTH 2010/11/18	CHECKED BY: JESSIE 2010/11/18	APPROVED BY: NAGESH 2010/11/18



PRODUCT SPECIFICATION

5.2 MECHANICAL REQUIREMENTS (continued)

ITEM	DESCRIPTION	TEST CONDITION	REQUIREMENT
14	Cable Flex	<p>100 cycles in each of 2 planes Dimension X = 3.7 x Cable Diameter</p> <p>Tested per EIA-364-41C, Condition I</p>	<p>Dielectric Withstanding Voltage: No Breakdown at 150 VAC</p> <p>&</p> <p>Insulation Resistance: At voltage of 150 VDC between adjacent terminals or ground.</p> <p>10 Megohms MINIMUM & Discontinuity < 1 microsecond</p>
15	Wrenching Strength	<p>Mated Connectors</p> <p>Apply a perpendicular force to a plug at a 15mm distance from the edge of the receptacle. Forces applied in 4 directions (up, down, left, and right)</p> <p>See Section 8.0 (Figures 1 & 2) for detailed test set-up</p>	<p>0-20N No Plug or Receptacle Damage & 20-40N No Receptacle Damage</p>
16	Cable Pull-Out	<p>Apply an axial load to the cable for 1 minute</p> <p>Tested per EIA-364-38C</p>	<p>40 N (9 lbf) MINIMUM pullout force</p> <p>Cable shall have no electrical discontinuity & Cable shall have no mechanical separation from the connector</p>

REVISION: 9	ECR/ECN INFORMATION: EC No: S2011-0455 DATE: 2010/11/19	TITLE: PRODUCT SPECIFICATION FOR 0.4mm PITCH, TYPE D MICRO HDMI CONNECTOR	SHEET No. 5 of 9
DOCUMENT NUMBER: PS-46765-003	CREATED / REVISED BY: SHANTH 2010/11/18	CHECKED BY: JESSIE 2010/11/18	APPROVED BY: NAGESH 2010/11/18



PRODUCT SPECIFICATION

5.3 ENVIRONMENTAL REQUIREMENTS

ITEM	DESCRIPTION	TEST CONDITION	REQUIREMENT
17	Shock (Thermal)	Mate connectors and expose to 10 cycles of: -55°C for 30 minutes +85°C for 30 minutes Tested per EIA-364-32C, Condition I	Contact: 30 milliohms MAXIMUM (change from initial). Shell: 50 milliohms MAXIMUM. (change from initial) Visual: No Damage
18	Humidity (Cyclic)	Mated Connectors: Temperature: +25 to 85°C Relative Humidity of 80 to 95% Duration: 4 cycles (96 hours) Note: Remove surface moisture & air dry for 24 hour prior to measurements. Tested per EIA-364-31B	Contact: 30 milliohms MAXIMUM (change from initial) Shell: 50 milliohms MAXIMUM (change from initial) Visual: No Damage
		Unmated Connectors Temperature: +25 to 85°C Relative Humidity of 80 to 95% Duration: 4 cycles (96 hours) Note: Remove surface moisture & air dry for 24 hours prior to measurements. Tested per EIA-364-31B	Dielectric Withstanding Voltage: No Breakdown at 150 VAC Insulation Resistance: 10 Megohms MINIMUM Visual: No Damage
19	Thermal Aging pre-conditioning	Mate connectors; expose to +105±2°C for 120 hours. Note: Remove surface moisture & air dry for 2 hours prior to measurements. Tested per EIA-364-17, Method A	Contact: 30 milliohms MAXIMUM (change from initial) Shell: 50 milliohms MAXIMUM (change from initial) Visual: No Damage
20	Thermal Aging	Mate connectors; expose to +105±2°C for 250 hours. Note: Remove surface moisture & air dry for 2 hours prior to measurements. Tested per EIA-364-17B, Condition 4, Method A	Contact: 30 milliohms Maximum (change from initial) Shell: 50 milliohms Maximum (change from initial) Visual: No Damage

REVISION: 9	ECR/ECN INFORMATION: EC No: S2011-0455 DATE: 2010/11/19	TITLE: PRODUCT SPECIFICATION FOR 0.4mm PITCH, TYPE D MICRO HDMI CONNECTOR	SHEET No. 6 of 9
DOCUMENT NUMBER: PS-46765-003	CREATED / REVISED BY: SHANTH 2010/11/18	CHECKED BY: JESSIE 2010/11/18	APPROVED BY: NAGESH 2010/11/18



PRODUCT SPECIFICATION

6.0 APPLICATION:

It is recommended to use Nitrogen in the reflow oven chamber

Recommended reflow profile:

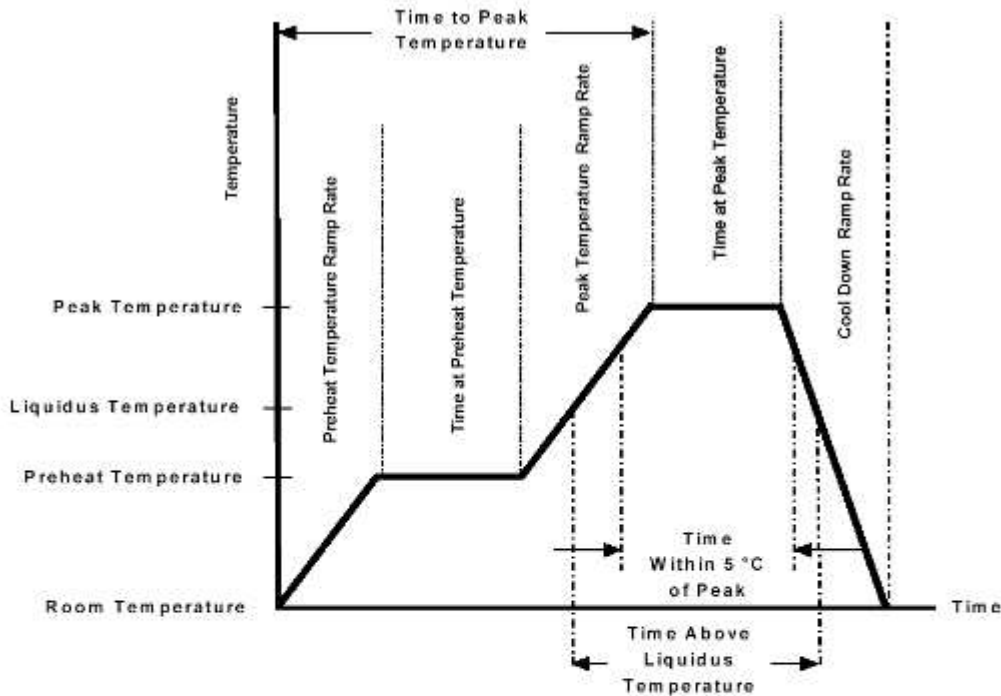

Description	Requirement
Average Ramp Rate	3°C/sec Max
Preheat Temperature	150°C Min to 200°C Max
Preheat Time	60 to 180 sec
Ramp to Peak	3°C/sec Max
Time over Liquidus (217°C)	60 to 150 sec
Peak Temperature	260 +0/-5°C
Time within 5°C of Peak	20 to 40 sec
Ramp - Cool Down	6°C/sec Max
Time 25°C to Peak	8 min Max

REVISION: 9	ECR/ECN INFORMATION: EC No: S2011-0455 DATE: 2010/11/19	TITLE: PRODUCT SPECIFICATION FOR 0.4mm PITCH, TYPE D MICRO HDMI CONNECTOR	SHEET No. 7 of 9
DOCUMENT NUMBER: PS-46765-003	CREATED / REVISED BY: SHANTH 2010/11/18	CHECKED BY: JESSIE 2010/11/18	APPROVED BY: NAGESH 2010/11/18



PRODUCT SPECIFICATION

7.0 PACKAGING

Parts shall be packaged in embossed tape to protect against damage during handling, transit and storage.

See appropriate sales drawings on Sheet 1 for packaging descriptions.

8.0 GAGES AND FIXTURES

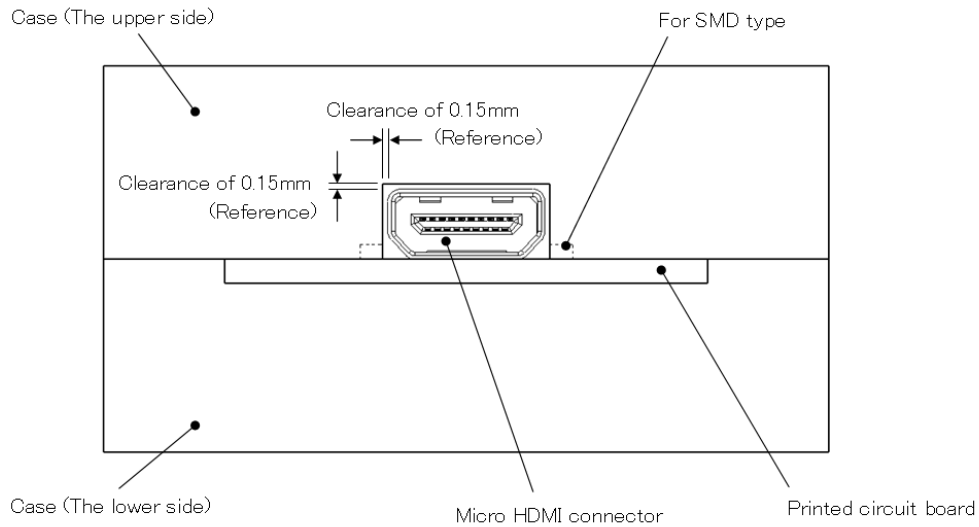

Figure 1

Test Set-Up for Wrenching Strength --- Normal μ HDMI

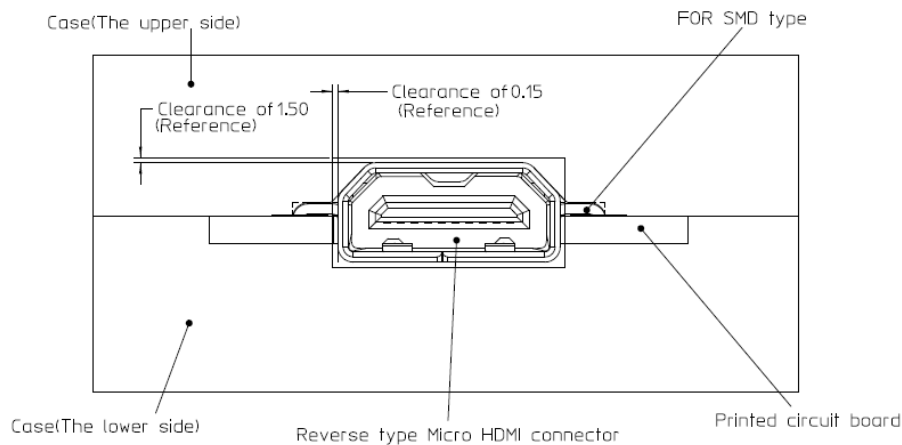

Figure 2

Test Set-Up for Wrenching Strength--- Reverse type μ HDMI

REVISION: 9	ECR/ECN INFORMATION: EC No: S2011-0455 DATE: 2010/11/19	TITLE: PRODUCT SPECIFICATION FOR 0.4mm PITCH, TYPE D MICRO HDMI CONNECTOR	SHEET No. 8 of 9
DOCUMENT NUMBER: PS-46765-003	CREATED / REVISED BY: SHANTH 2010/11/18	CHECKED BY: JESSIE 2010/11/18	APPROVED BY: NAGESH 2010/11/18



PRODUCT SPECIFICATION

TEST SEQUENCE CHART

Test	Reliability Lab												
	1	2	3	4	5	6	7	8	9	10	11	12	13
Contact Resistance	1,4,6	1,4,6,8		1,4,6,8		2,7							
Insulation Resistance			1,7		1,5								
Dielectric Withstanding Voltage			2,6		2,4								
Durability, Preconditioning	2	2	3	2									
Durability					3	4							
Thermal Aging, Preconditioning				3									
Thermal Aging	3												
Thermal Shock		3	4										
Cyclic Temperature and Humidity		5	5										
Thermal Disturbance													
Vibration				5									
Mechanical Shock				7									
Reseating	5	7											
Insertion and Withdrawal Forces						1,3,5,6							
Cable Flex							1						
Wrenching Strength								1					
Cable Pull-Out									1				
Current Rating										1			
Applied Voltage Rating											1		
Electrostatic Discharge												1	
TMDS Signal Time Domain Impedance													1
TMDS Signal Time Domain Cross Talk FEXT													2
SAMPLES	5	5	5	5	5	5	5	5	5	5	3	3	3

REVISION: 9	ECR/ECN INFORMATION: EC No: S2011-0455 DATE: 2010/11/19	TITLE: PRODUCT SPECIFICATION FOR 0.4mm PITCH, TYPE D MICRO HDMI CONNECTOR	SHEET No. 9 of 9
DOCUMENT NUMBER: PS-46765-003	CREATED / REVISED BY: SHANTH 2010/11/18	CHECKED BY: JESSIE 2010/11/18	APPROVED BY: NAGESH 2010/11/18