

STUD SIZE	±.007 "S" DIA.	REF. "K" DIA.
#6	.146	.236
#8	.173	.263
#10	.198	.288

D

D

C

C

B

B

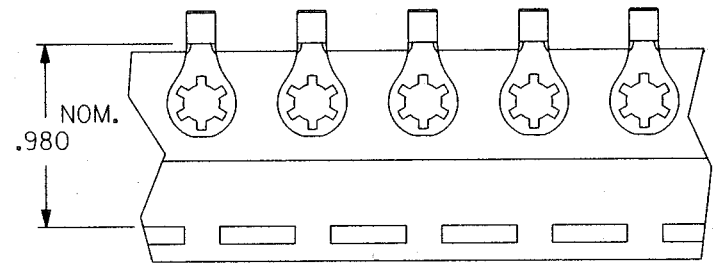
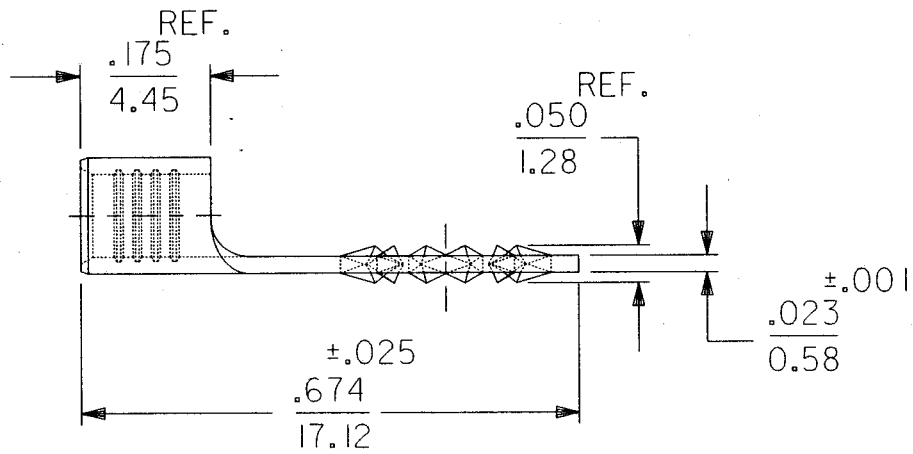

TO ORDER PARTS ON TAPE ADD A "T" TO THE END OF THE PART NUMBER

TERMINAL MATERIAL: SEE CHART
TERMINAL PLATING: ELECTRO-TIN

PART NO. BRASS	PART NO. STEEL	WIRE RANGE AWG / MM ²	I.D. MIN.
SRA-129-	SRA-S-129-	22-18/.25-1.3	.073/1.85 (B)
SRB-129-	SRB-S-129-	16-14/1.0-2.6	.100/2.54 (B)

B	ETC2005-1112 ID TYPO RWD 05/01/05
A	SEE DCN# 764 10/07/91 RCM
LTR.	REVISIONS

A

A

REVISE ONLY ON CAD SYSTEM

TITLE
KRIMPTITE
STAR RING TONGUE
TERMINALS

SALES
DRAWING

DRWG. BY	RCM
CHK'D. BY	JM
APP'D. BY	FP
SCALE	NO:NE

moLEX ETC INC.
PINELLAS PARK, FLA. 34665 U.S.A.

PART NO. SEE TABLE

DRWG. NO. CD-1115

SHEET NO. DATE 09/05/91

FILE NAME CD1115 THIS DRAWING CONTAINS INFORMATION THAT IS PROPRIETARY TO MOLEX-ETC INC. AND SHOULD NOT BE USED WITHOUT WRITTEN PERMISSION. DIV. SIZE A