

1. 97-521.1 PIERCE, SLOT & FORM DIE
 2. DECREASE
 3. H.T. (OVEN)

4. FINAL INSPECTION
 5. STOCK
 6. FINISH AS REQ'D
 7. 97-521.3 A - 44 15 FIBRENT PPHHXK
 8. FINAL INSP.
 9. SHIPPING

OP'S REVISED FINISH TABLE REMOVED K.D. 9-21-81	DETAIL ADDED 74 3/24/82	TENSILE STRENGTH APPLIED MATERIAL K.O. 1-25-83	1-062 WAS .040 OP'S #G-9 ADDED PATENT NO. 1 STICKY FINGERS ADDED K.D. 3-22-83	5 10°-20° WAS 20°-20° K.D. 5-11-83	TOOL NUMBER ADDED TO CP#1 74 6-23-83	500 G. LOAD, WAS 200 G. LOAD, F-11-83	8 ADDED 25.2" ±.2" NOTE - EGN 1056 74 W/HA 23-87	9 ECO-E 5167 ADDED .030 MIN DIM. 2° NOTE 8DH 9/22/05	10 96 9/18/86	11 ECO-E5429 REMOVED 2° NOTE 8DH 5/15/06 EWS 6-1-86
--	-------------------------------	--	---	---	---	---	--	--	------------------	---

0097-D-0521

TOL. UNLESS OTHERWISE SPEC.:
 DEC. H .005
 FRACT. H H
 ANGLES H

ECO E5542
 ADDED 1150 DIM
 806 10/17/06
 EWS 10-19-88 12

PATENT NO. 3504095
 STICKY FINGERS®

REFER TO 97-D-520 FOR ALL SPECIFICATIONS NOT SHOWN

NOTE: WHEN SUPPLIED IN 25 FOOT COILS LENGTH CUT FROM PRESS TO BE 25' 2 1/2" ± 2"

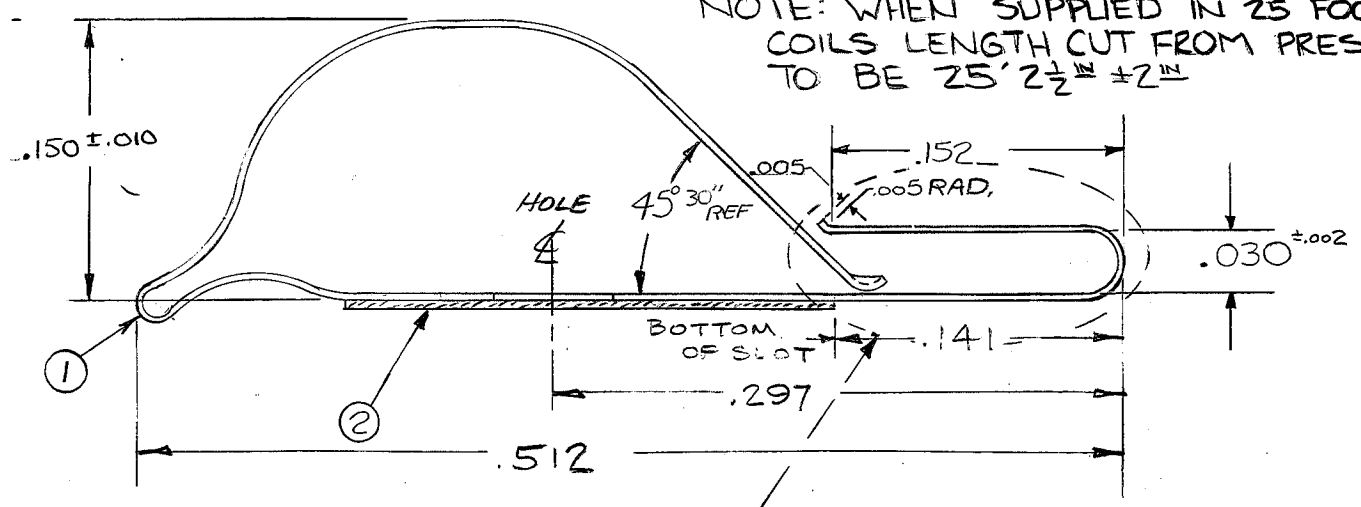

MAKE IN 16" LENGTHS
 H.T. TO DPH 373 MIN
 USING 500 GRAM LOAD
 THICKNESS AFTER CLEANING .00265 MIN.
 FINISH AS REQUIRED.

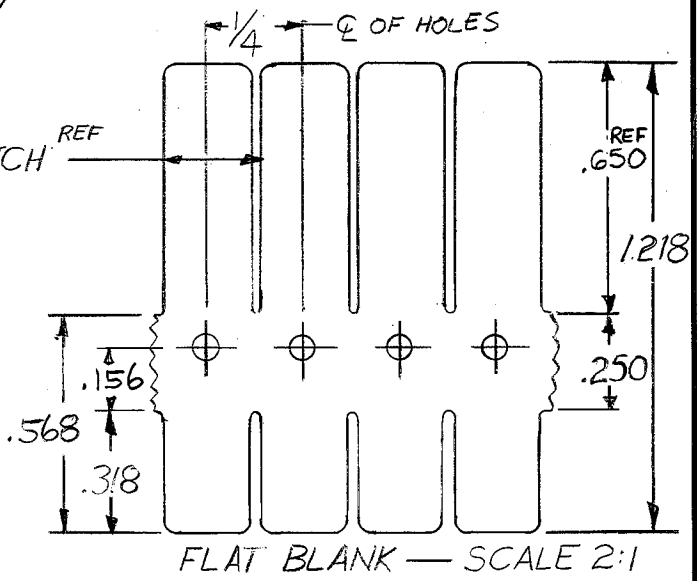
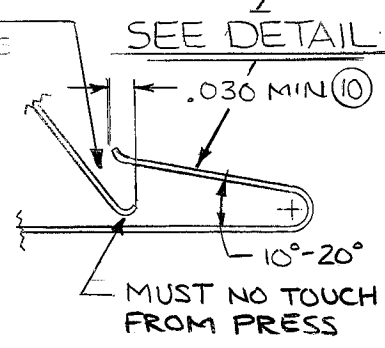
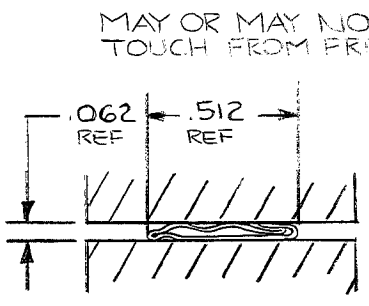

② SEE DWG 97-D 446 - 1/4 WIDE PRESSURE SENSITIVE TAPE
 CUT 1/4 INCH SPECIMEN ACROSS STRIP, BEND 30° WITH WIPING
 MOTION AROUND .125 DIA PIN. WHEN RELEASED, THE RADIUS
 OF BEND SHALL BE BETWEEN .090-1.00 OR TENSILE STRENGTH 70,000-80,000
 PSI

MATERIAL: ① .003 ±.0001 x 1 3/4 ±.003 BE. CU. STRIP #25 ALLOY - 1/4 HARD

INSTRUMENT SPECIALTIES COMPANY, Inc. LITTLE FALLS, NEW JERSEY				LBS/M 22.0	DOUBLE FOLDED SHEILDING STRIP
DRAWN BY T.A. DATE 5/28/81 APPROVED [Signature] DATE 7-9-81 SCALE 2:1 10:1				SUB 12	REF. DWG. 97-D-520 "
				DWG. NO.	0097-D-0521