

THIS DRAWING IS UNPUBLISHED. RELEASED FOR PUBLICATION
 © COPYRIGHT BY TYCO ELECTRONICS CORPORATION. ALL RIGHTS RESERVED.

LOC	DIST	REVISIONS			
P	LTR	DESCRIPTION	DATE	DWN	APVD
AJ	00	B	REV PER ECO 07-027471	1/16/2008	DW JL

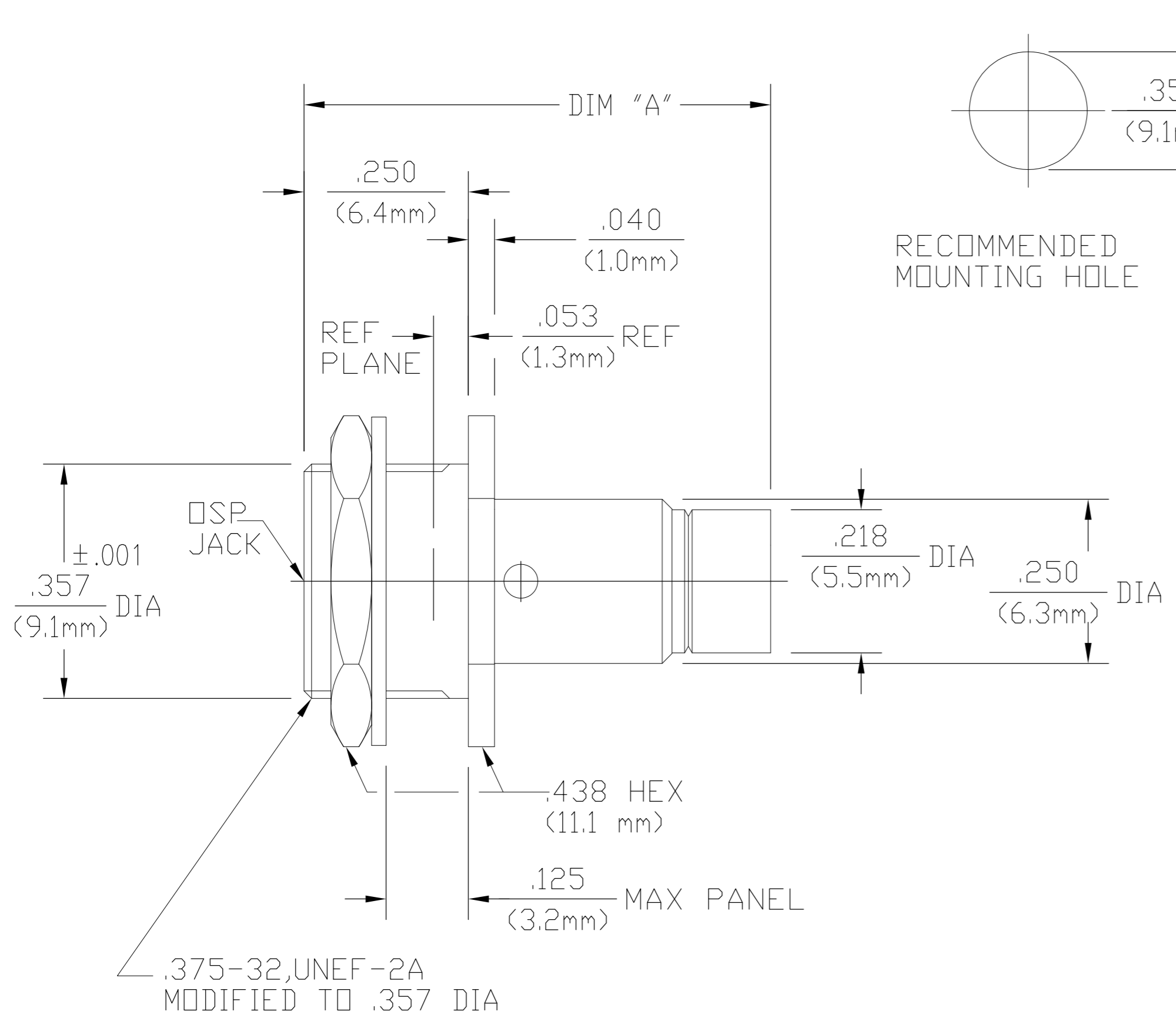

RECOMMENDED MOUNTING HOLE

DIM "A"	
BEFORE CRIMPING	.830 REF <21.1mm>
AFTER CRIMPING	.710 <18.0mm>

NOTES:

- DESIGNED FOR USE WITH .141 DIA (RG 402/U) SEMI-RIGID CABLE
- CAPTURED CENTER CONTACT
- PICTORIAL VIEW IS AFTER CRIMPING
- MINIMUM STRAIGHT CABLE LENGTH .341
- IT IS SUGGESTED TO BEND CABLE PRIOR TO CRIMPING

1059408-1
PART NUMBER

COMPONENT	MATERIAL	FINISH
HOUSING BUSHING	STAINLESS STEEL PER ASTM-A484 AND ASTM-A582, TYPE 303	PASSIVATE PER ASTM-A380
DIELECTRIC	TFE FLUOROCARBON PER ASTM-D-1457	N/A
CENTER CONTACT	BERYLLIUM COPPER PER ASTM B 196, ALLOY C17300, CONDITION H	GOLD PLATE PER MIL-G-45204 OVER COPPER PLATE PER MIL-C-14550
CONTACT SLEEVE	BERYLLIUM COPPER PER ASTM B 196, ALLOY C17300, CONDITION H	GOLD PLATE PER MIL-G-45204
SHIM CONTACT RING	BERYLLIUM COPPER PER ASTM B 194, ALLOY C17200, CONDITION H	GOLD PLATE PER MIL-G-45204 OVER COPPER PLATE PER MIL-C-14550
LOCKWASHER	PHOSPHOR BRONZE PER QQ-B-750, GRADE B2 OR TIN BRASS PER ASTM-B-591	NICKEL PLATE PER QQ-N-290 OVER COPPER PLATE PER MIL-C-14550
MOUNTING NUT	BRASS PER ASTM-B-16 HALF HARD	NICKEL PLATE PER QQ-N-290 OVER COPPER PLATE PER MIL-C-14550

CABLE ENTRY DIAMETER MINIMUM	.143	THIS DRAWING IS A CONTROLLED DOCUMENT.		DWN D.CAM 8-16-83	Tyco Electronics Corporation Harrisburg, PA 17105-3608
HOUSING CONTACT	.037	DIMENSIONS: INCHES	TOLERANCES UNLESS OTHERWISE SPECIFIED:	CHK R.GURES 8-26-83	
			0 PLC ± -	APVD T.SCONLI 8-29-83	NAME OSP BULKHEAD FEEDTHROUGH CABLE JACK COMPRESSION CRIMP ATTACHMENT (4504-7641-02)
			1 PLC ± -	2 PLC ± -	
			3 PLC ± .005	APPLICATION SPEC	SIZE CAGE CODE DRAWING NO
			4 PLC ± -	408-04594	A2 00779 C=1059408-1
			ANGLES ± 1'	WEIGHT -	RESTRICTED TO
		MATERIAL -	FINISH -	CUSTOMER DRAWING	SCALE 1:1 SHEET 1 of 1 REV B