

ENGAGEMENT FIGURE (20:1)

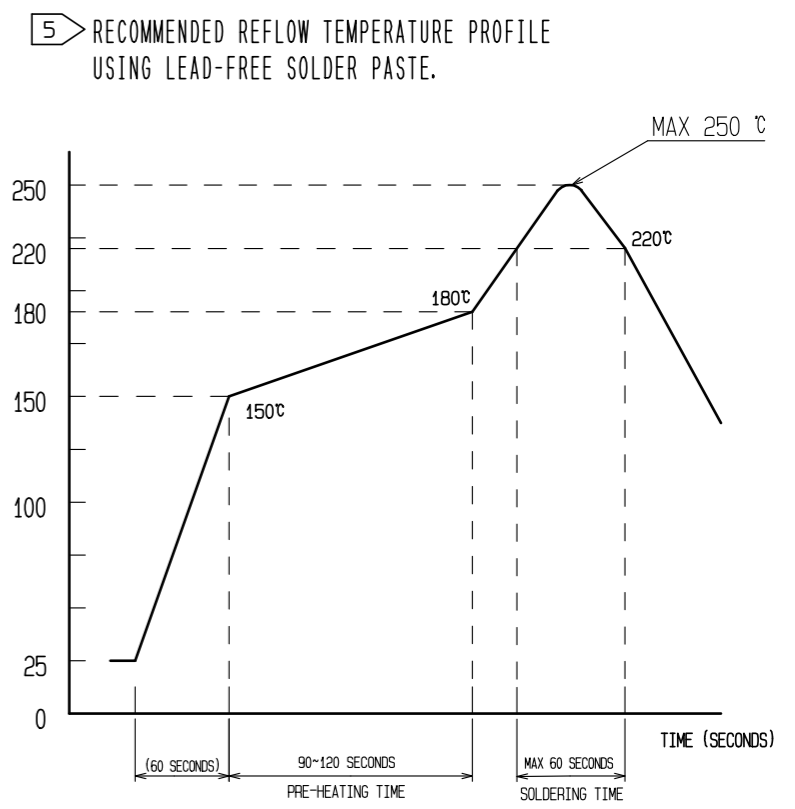
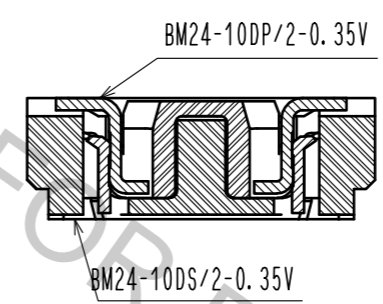
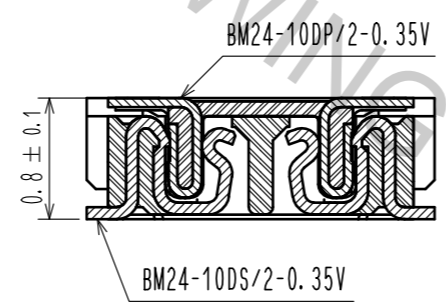

REFLOW METHOD: IR REFLOW
 NUMBER OF REFLOW CYCLES: 2 CYCLES MAX.
 1) REFLOW TIME
 DURATION ABOVE 220°C, 60 SEC MAX.
 (PEAK TEMPERATURE: 250°C MAX)
 2) PRE-HEAT TIME
 PRE-HEAT TEMPERATURE (MIN): 150°C
 PRE-HEAT TEMPERATURE (MAX): 180°C
 PRE-HEAT TIME: 90-120 SEC.

- NOTE 1. ALL LEAD CO-PLANARITY SHALL BE 0.08mm MAX.
 2 CONTACT PLATING SPECIFICATIONS
 CONTACT AREA : GOLD 0.05 μm MIN
 SMT LEAD : GOLD 0.05 μm MIN
 UNDER PLATING : NICKEL 1 μm MIN
 (SURFACE : SEALING)
 3 A PART OF THE WALL COULD BE NOTCHED.
 4 HRS MARK AND CAV No. ARE INDICATED IN APPROX. POSITION SHOWN.

◆ RECOMMENDED PCB LAYOUT

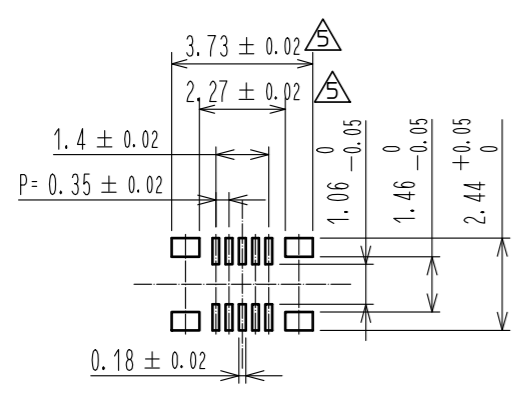

◆ RECOMMENDED METAL MASK DIMENSIONS
 METAL MASK THICKNESS : 100 μm

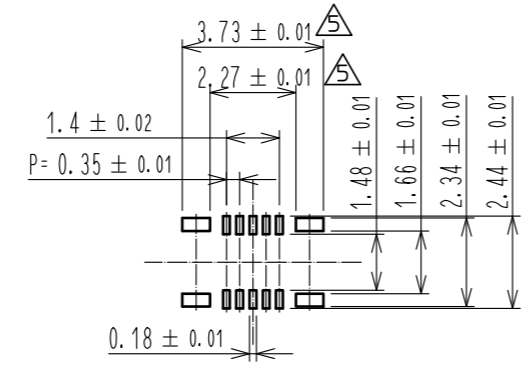

5 THIS TEMPERATURE PROFILE IS PER THE CONDITIONS SHOWN ABOVE. ADDITIONAL FACTORS, SUCH AS SOLDER PASTE TYPE, PCB SIZE AND OTHER MOUNTED COMPONENTS COULD AFFECT THE PROFILE. THEREFORE, A THOROUGH EVALUATION OF MOUNTING COONDITION IS REQUIRED PRIOR TO PRODUCTION. TEPERATURE IS MEASURED AT CONTACT LEAD.
 6. PLEASE CONTACT US IN CASE YOU WILL MAKE DIFFERENT SETTINGS FROM OUR RECOMMENDATION.

4	PS	CLEAR(EMBOSSED CARRIER TAPE)					
3	COPPER ALLOY	2	7	PS	CLEAR (REINFORCEMENT COLLAR)		
2	PHOSPHOR BRONZE	2	6	PS	BLACK (PLASTIC REEL)		
1	LCP	UL94 V-0. BLACK	5	POLYESTER	CLEAR (COVER TAPE)		
NO.	MATERIAL	FINISH . REMARKS	NO.	MATERIAL	FINISH . REMARKS		
UNITS mm		SCALE 10 : 1	COUNT 4	DESCRIPTION OF REVISIONS DIS-H-00001151	DESIGNED NY. YAMASHIRO	CHECKED TS. MIYAZAKI	DATE 15. 12. 03
HRS HIROSE ELECTRIC CO., LTD.		APPROVED : KH. IKEDA	13. 11. 06	DRAWING NO. EDC3-352539-01			
		CHECED : WR. FUKUCHI	13. 11. 06	PART NO. BM24-10DP/2-0.35V(51)			
		DESIGNED : YH. HASEGAWA	13. 11. 06	CODE NO. CL677-2001-9-51			
		DRAWN : YH. HASEGAWA	13. 11. 06	1/2			

EMBOSSED CARRIER TAPE PACKAGING (FREE)

STYLE AND DIMENTION OF REEL (FREE)

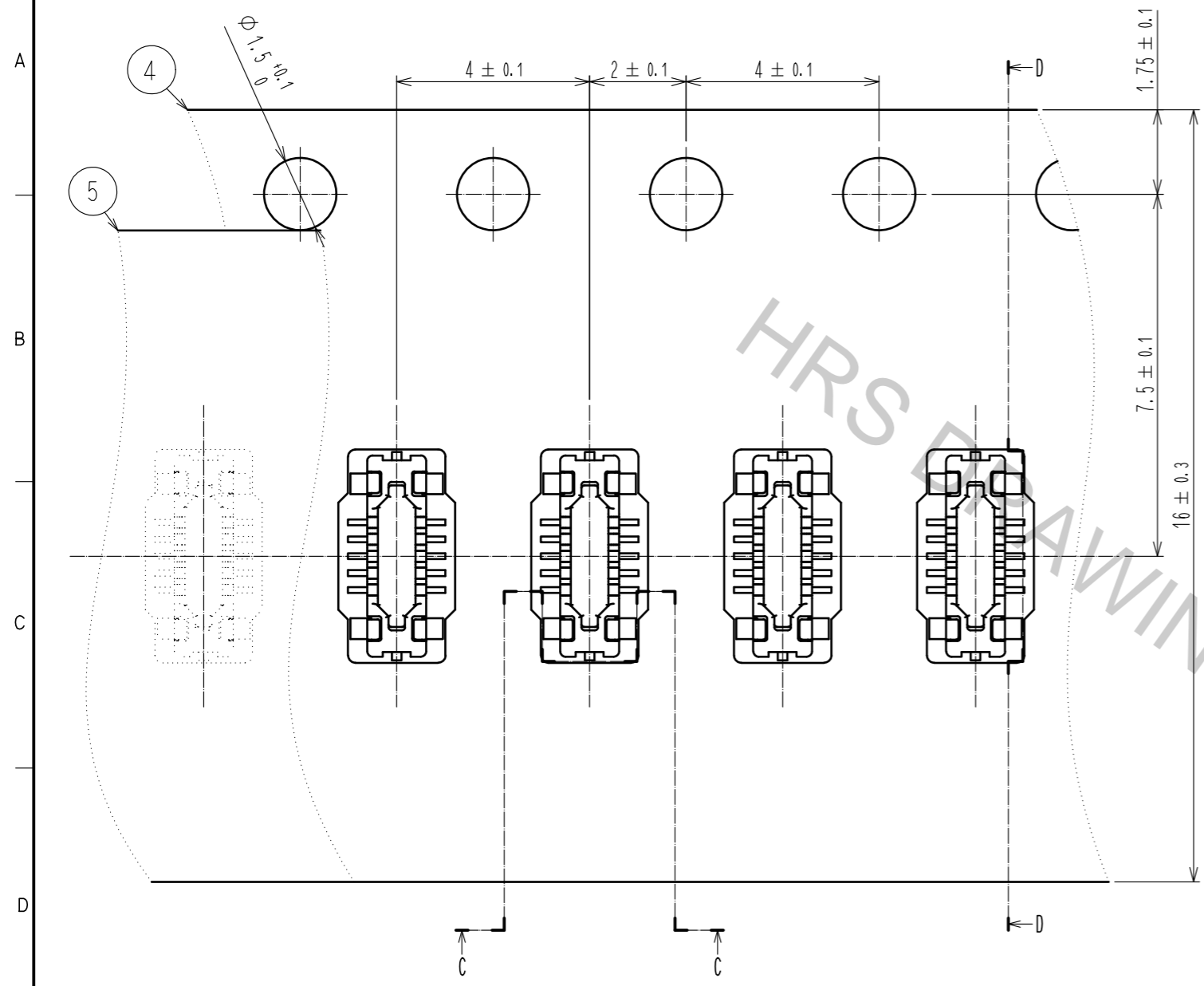

D-D (FREE)

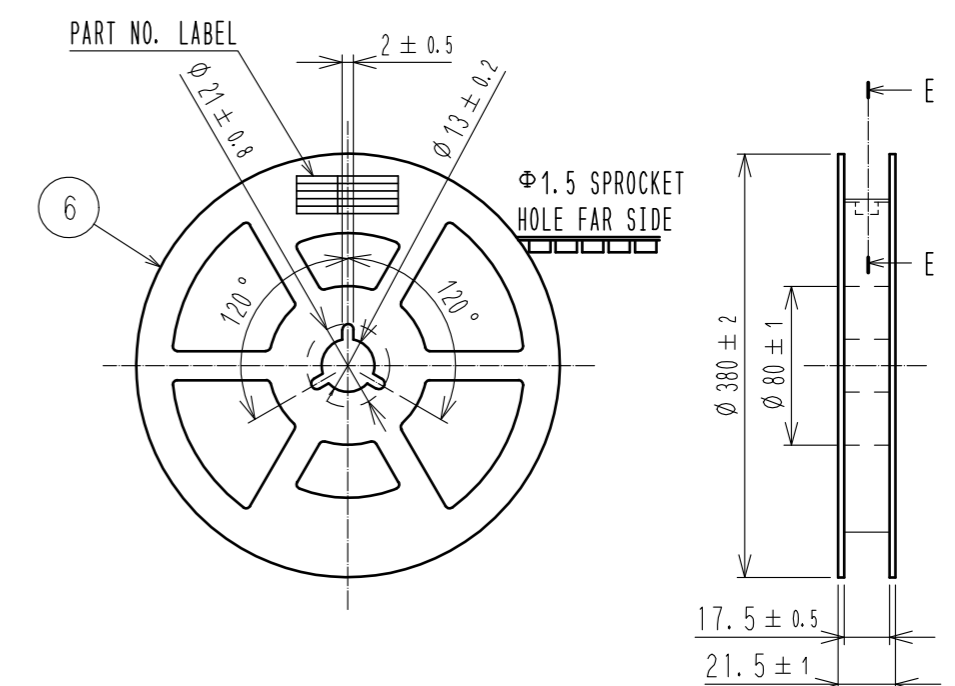
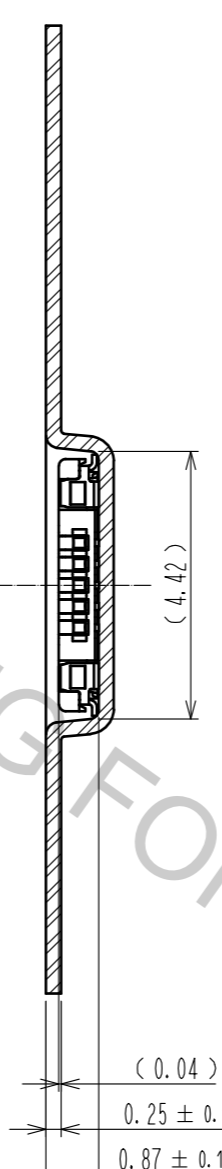

E-E (FREE)

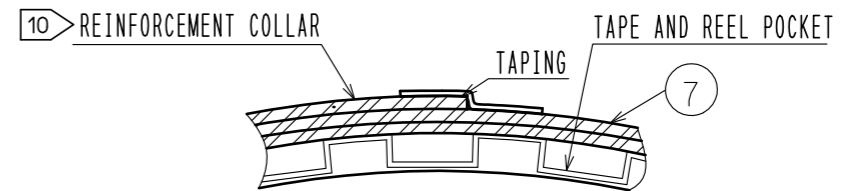

DETAIL OF PART NO. LABEL

製造年月日	** ** *
製品コード	CL0677-2001-9(51)
製品名	BM24-10DP/2-0.35V(51)
数量	10,000
納入者	ヒロセ電機(株)

DATA OF MANUFACTURED
 CODE NO.
 PART NO.
 QUANTITY
 SUPPLIER

C-C (FREE)

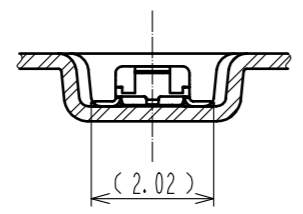

DIRECTION OF UNREELING

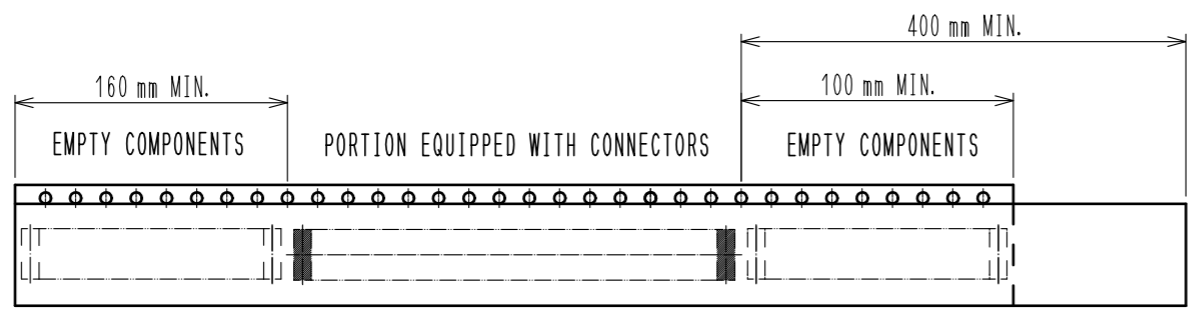
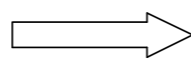

9 TAPING (FREE)

- 7 . PER REEL 10,000 CONNECTORS.
- 8 . THE DIMENSIONS IN PARENTHESES ARE FOR REFERENCE.
- 9 . REFER TO JIS C 0806(PACKAGING OF COMPONENTS FOR AUTOMATIC HANDLING)
- 10 . AFTER PACKAGING. ROLL 2 METERS OF THE REINFORCEMENT COLLAR TO OUTER CIRCUMFERENCE OF TAPE AND REEL POCKET. AND TAPE DOWN AT THE END THE COLLAR.

HRS	DRAWING NO.	EDC3-352539-01
	PART NO.	BM24-10DP/2-0.35V(51)
	CODE NO.	CL677-2001-9-51
		2/2