

THIS DRAWING IS UNPUBLISHED. RELEASED FOR PUBLICATION 20
 © COPYRIGHT 20 BY - ALL RIGHTS RESERVED.

| LOC | | DIST | | REVISIONS | | | |
|-----|-----|-------------|----------|-----------|------|----|--|
| P | LTR | DESCRIPTION | DATE | DWN | APVD | | |
| - | - | A | RELEASED | 21NOV2013 | JW | SH | |

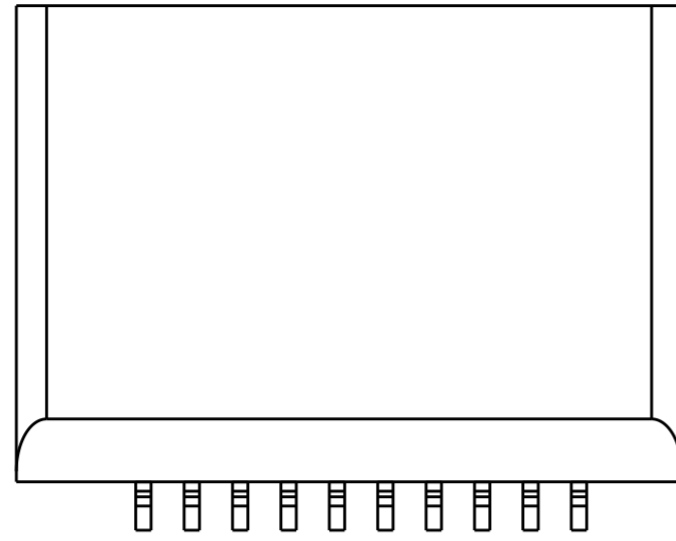

1 MATERIAL:
 CONTACT: COPPER ALLOY
 HOUSING: THERMOPLASTIC

2 FINISH:
 CONTACT AREA: GOLD FLASH OVER PALLADIUM-NICKEL
 OR GOLD PLATING, 0.76um MIN TOTAL
 SOLDER AREA: GOLD FLASH
 UNDERPLATING: 2.54um MIN NICKEL OVER ALL

3 FINISH:
 CONTACT AREA: GOLD FLASH OVER PALLADIUM-NICKEL
 OR GOLD PLATING, 0.38um MIN TOTAL
 SOLDER AREA: GOLD FLASH
 UNDERPLATING: 2.54um MIN NICKEL OVER ALL

4 PART NUMBER AND DATE CODE APPROXIMATELY
 MARKED IN THIS AREA.

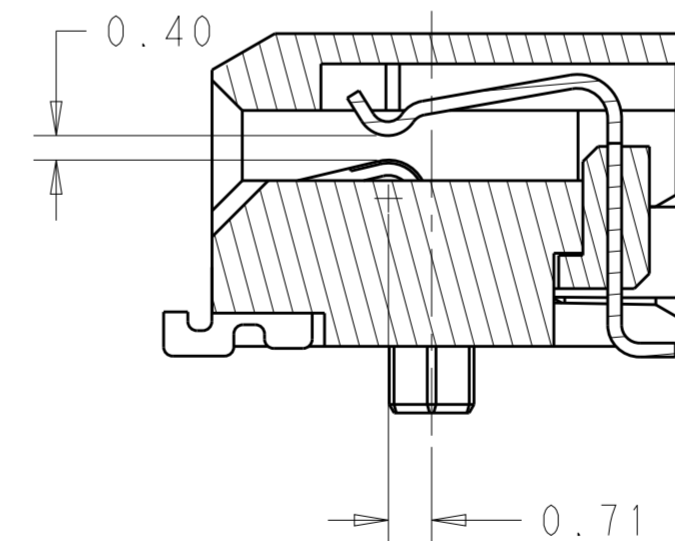
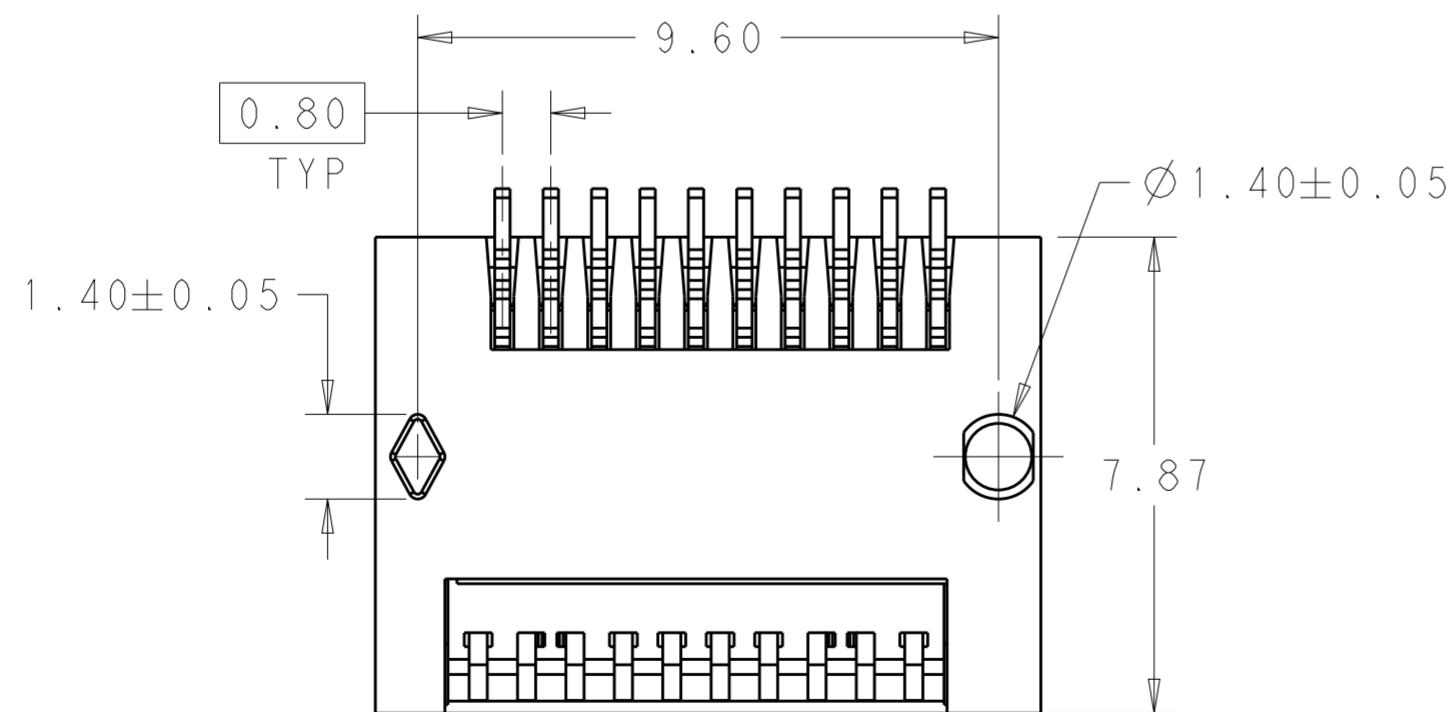
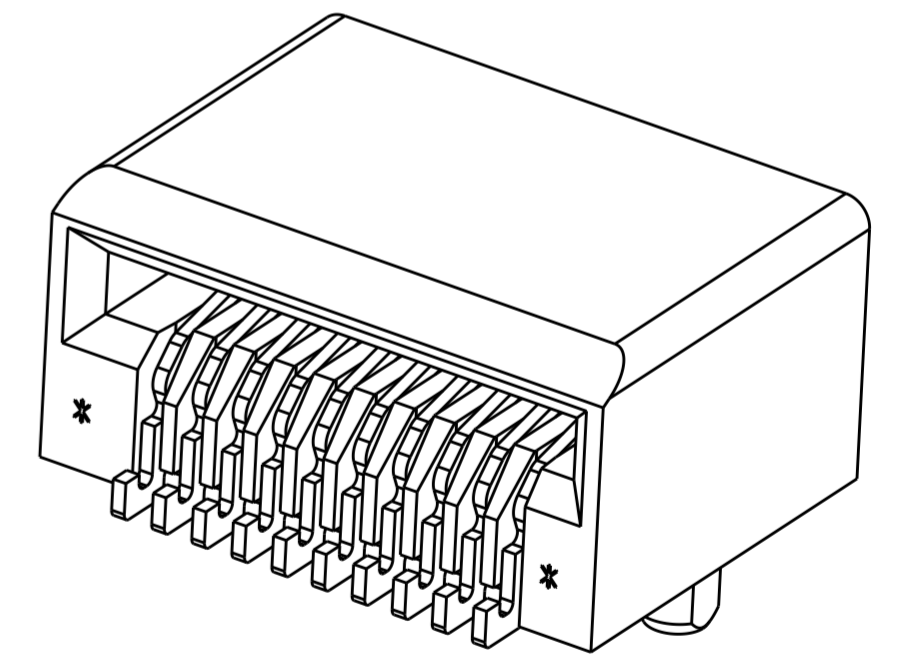
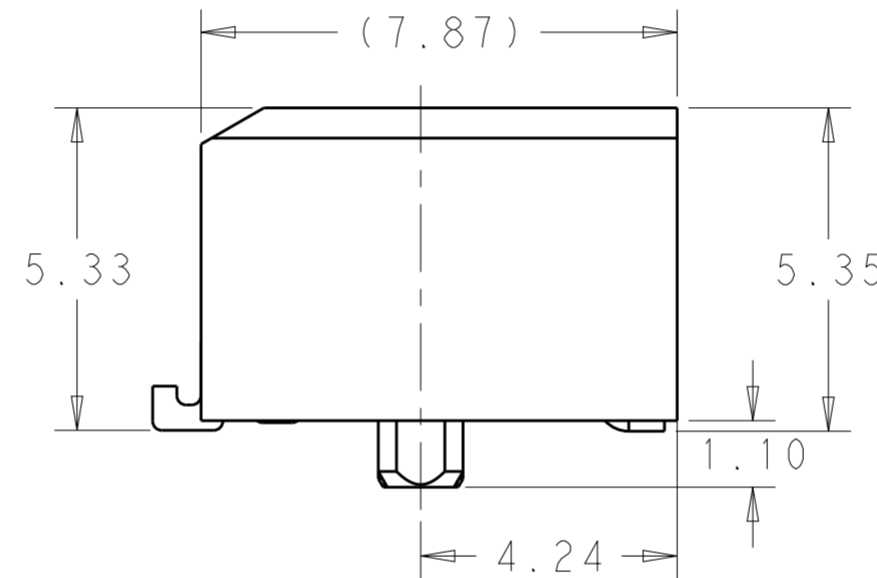
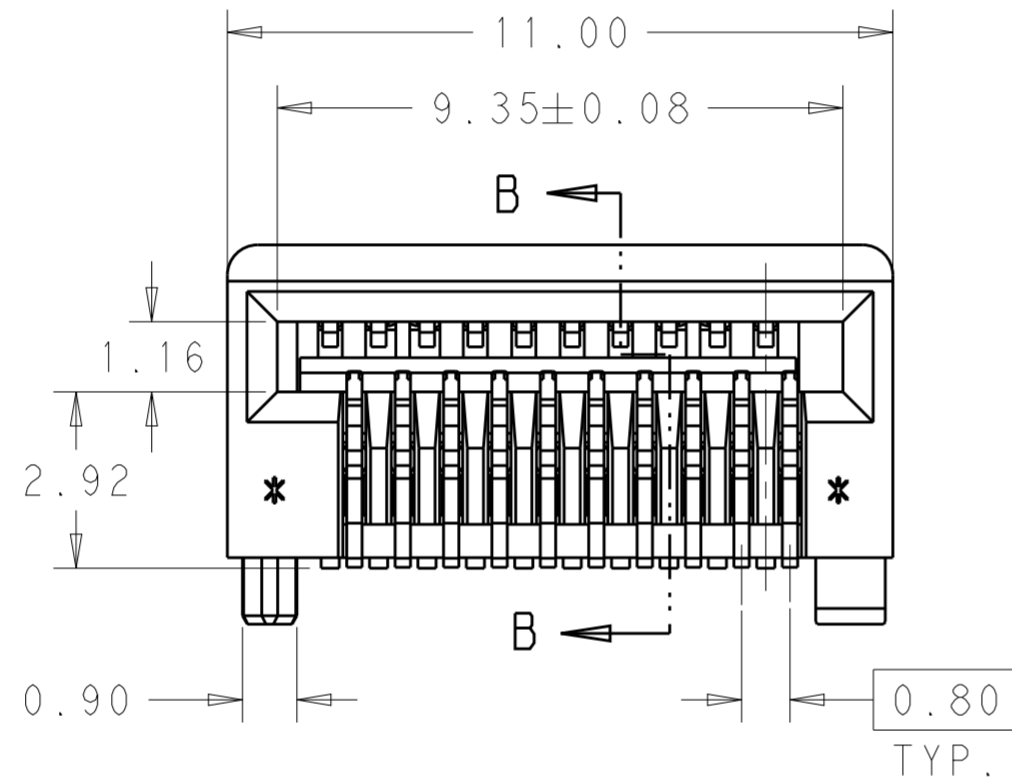
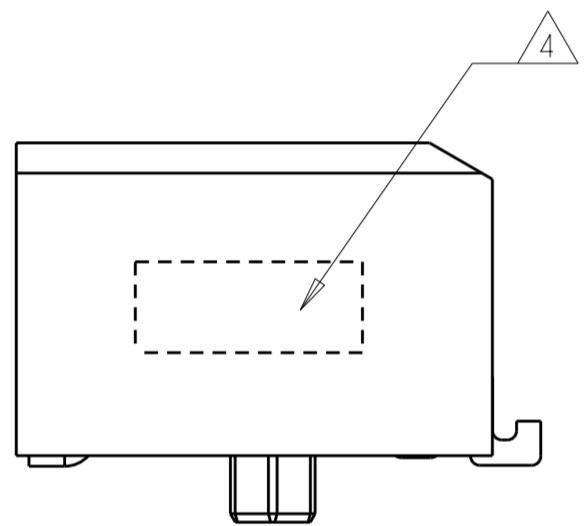

SECTION B-B

| | |
|--------|-------------|
| 1 | 2170088-2 |
| 2 | 2170088-1 |
| FINISH | TE PART NO. |

| | | | | |
|--|-------------|-----------------------------------|---------------------------------------|-------------------------|
| THIS DRAWING IS A CONTROLLED DOCUMENT. | | DWN ALEX SHOAL 28MAR2011 | STE TE Connectivity | |
| DIMENSIONS: mm | | CHK MANQIAN WANG 28MAR2011 | ASSEMBLY DRAWING SMT, 20POS, ZSFP+ | |
| TOLERANCES UNLESS OTHERWISE SPECIFIED: | | APVD MANQIAN WANG 28MAR2011 | NAME | |
| 0 PLC ± | 1 PLC ±0.25 | PRODUCT SPEC | 108-60099 | |
| 2 PLC ±0.13 | 3 PLC ± | APPLICATION SPEC | 114-13120 | |
| 4 PLC ± | ANGLES ± | WEIGHT | - | |
| MATERIAL 1 | FINISH 2 3 | Customer Drawing | SIZE A200779 | DRAWING NO C-2170088 |
| SCALE 8:1 | | | SHEET 1 OF 2 | REV A |

THIS DRAWING IS UNPUBLISHED. RELEASED FOR PUBLICATION 20
 © COPYRIGHT 20 BY - ALL RIGHTS RESERVED.

| LOC | | DIST | | REVISIONS | | | |
|-----|-----|-------------|------|-----------|------|--|--|
| P | LTR | DESCRIPTION | DATE | DWN | APVD | | |
| - | - | SEE SHEET 1 | - | - | - | | |

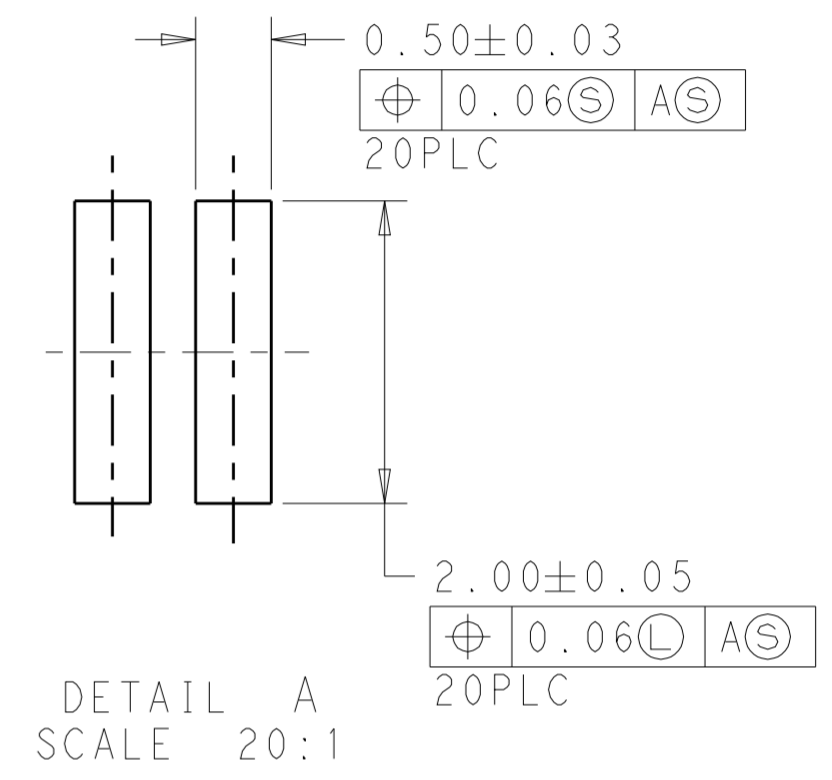
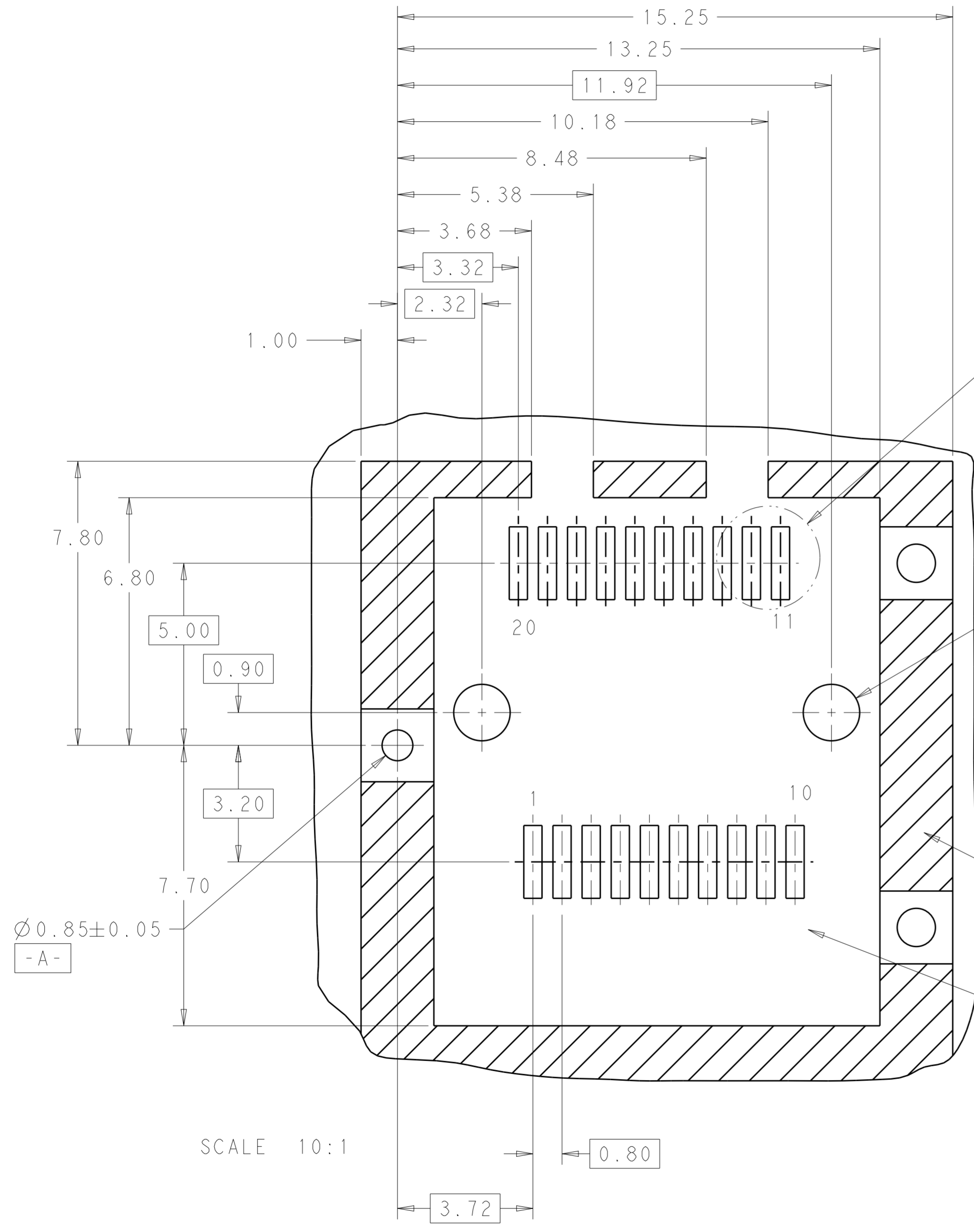

Ø1.55±0.05
 ⊕ Ø0.1Ⓛ AS

CROSS HATCHED AREA DENOTES
 COMPONENT AND TRACE KEEP-OUT
 (EXCEPT CHASIS GROUND)

THIS AREA DENOTES
 COMPONENT KEEP-OUT
 (TRACES ALLOWED)

SCALE 10:1

| | | | | |
|---|--|-----------------------------------|---|-------------------------|
| THIS DRAWING IS A CONTROLLED DOCUMENT. | | DWN ALEX SHOAL 28MAR2011 | TE Connectivity | |
| DIMENSIONS: mm | | CHK MANQIAN WANG 28MAR2011 | | |
| TOLERANCES UNLESS OTHERWISE SPECIFIED: | | APVD MANQIAN WANG 28MAR2011 | NAME ASSEMBLY DRAWING SMT, 20POS, ZSFP+ | |
| 0 PLC ± 1 PLC ±0.25 2 PLC ±0.13 3 PLC ± 4 PLC ± ANGLES ± FINISH ± | | PRODUCT SPEC 108-60099 | RESTRICTED TO | |
| MATERIAL | | APPLICATION SPEC 114-13120 | SIZE A200779 | DRAWING NO C-2170088 |
| | | WEIGHT | SCALE 8:1 SHEET 2 OF 2 REV A | |
| | | Customer Drawing | | |