

REVISION D

DO NOT SCALE FROM THIS PRINT

PCMT-1XX-XX-X-D-RA-XX-SL-XX

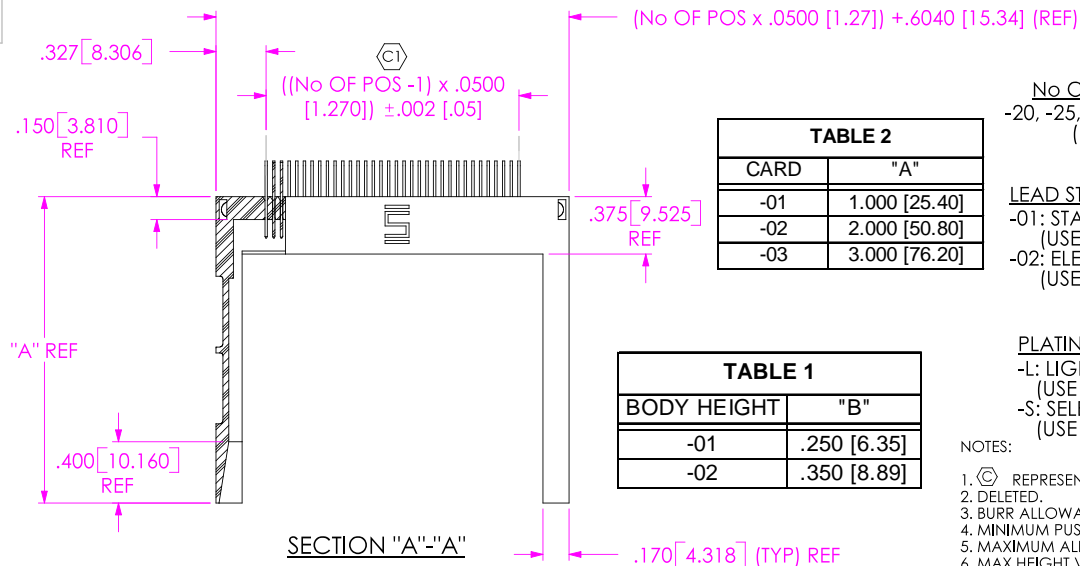

TABLE 2

CARD	"A"
-01	1.000 [25.40]
-02	2.000 [50.80]
-03	3.000 [76.20]

TABLE 1

BODY HEIGHT	"B"
-01	.250 [6.35]
-02	.350 [8.89]

No OF POSITIONS
-20, -25, -30, -34, -40, -50 (PER ROW)

LEAD STYLE
-01: STANDARD (USE PCMT-XX-D-S-XX-SL)
-02: ELEVATED (USE PCMT-XX-E-S-XX-SL)

PLATING SPECIFICATION
-L: LIGHT SELECTIVE GOLD (USE T-1S15-09-L)
-S: SELECTIVE GOLD (USE T-1S15-09-S)

POST OPTION
-SD: STANDARD .120 [3.05]
-BLANK: HOT PLUGGABLE (34 POS ONLY)

-SL: SOLDER LOCK

CARD LENGTH
-01: 1 [25.40] INCH (USE PCMT-XX-X-S-01-SL)
-02: 2 [50.80] INCH (USE PCMT-XX-X-S-02-SL)
-03: 3 [76.20] INCH (USE PCMT-XX-X-S-03-SL)

TAIL OPTION
-RA: RIGHT ANGLE

ROW SPECIFICATION
-D: DOUBLE (USE PCMT-XX-D-X-XX-SL)

NOTES:

1. Ⓢ REPRESENTS A CRITICAL DIMENSION.
2. DELETED.
3. BURR ALLOWANCE: .0015 [0.038] MAX.
4. MINIMUM PUSHOUT FORCE: 1 LB.
5. MAXIMUM ALLOWABLE BOW: .002 [0.05] INCH/INCH AFTER ASSEMBLY.
6. MAX HEIGHT VARIATION .005 [0.13] BETWEEN ROWS.
7. DELETED.
8. TERMINALS TO BE SHEARED TO OBTAIN DIMENSION SPECIFICATION.
9. PARTS TO BE PACKAGED IN TUBES.
10. DIMENSION TO BE MEASURED AT BEND.

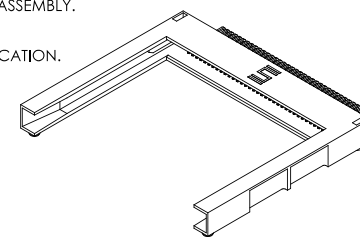

FIG. 1

PCMT-1XX-01-X-D-RA-02-SL SHOWN

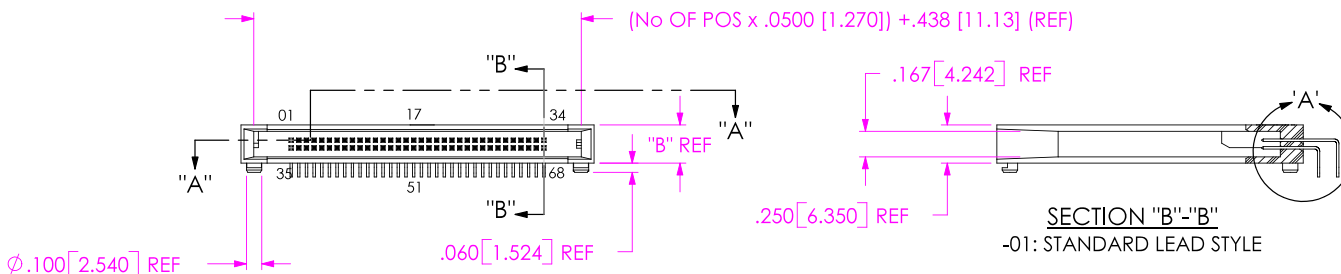
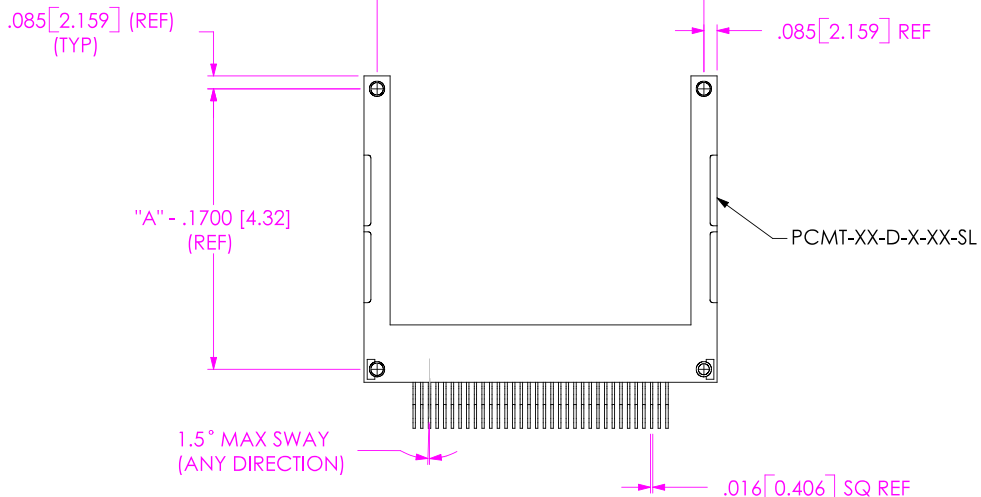
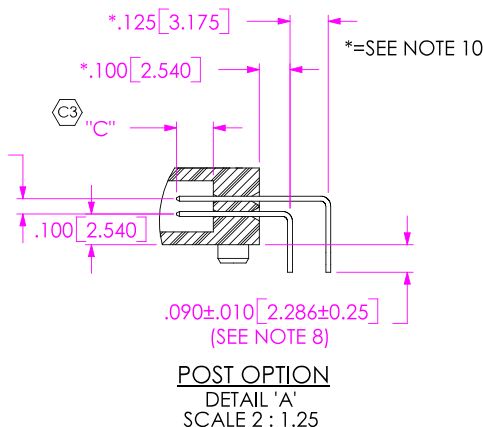

TABLE 4

POST OPTION	POSITION	"C"
-HP	36, 67	.138 [3.51]
-HP	01, 17, 34, 35, 51, 68	.197 [5.00]
-HP	ALL OTHERS	.167 [4.21]
-SD	ALL	.120 [3.05]



UNLESS OTHERWISE SPECIFIED, DIMENSIONS ARE IN INCHES.
TOLERANCES ARE:
DECIMALS ANGLES
.XX: $\pm .01$ [0.3] 2°
.XXX: $\pm .005$ [0.13]
.XXXX: $\pm .0020$ [0.051]

PROPRIETARY NOTE
THIS DOCUMENT CONTAINS INFORMATION CONFIDENTIAL AND PROPRIETARY TO SAMTEC, INC. AND SHALL NOT BE REPRODUCED OR TRANSFERRED TO OTHER DOCUMENTS OR DISCLOSED TO OTHERS OR USED FOR ANY PURPOSE OTHER THAN THAT WHICH IT WAS OBTAINED WITHOUT THE EXPRESSED WRITTEN CONSENT OF SAMTEC, INC.

MATERIAL: DO NOT SCALE DRAWING SHEET SCALE: 1:1.25
INSULATOR: VECTRA E130I
COLOR: BLACK
TERMINAL: 510 PHOS BRONZE, SPRING TEMPER

DESCRIPTION:
.050 [1.27] CARD GUIDE ASSEMBLY

DWG. NO.
PCMT-1XX-XX-X-D-RA-XX-SL-XX

BY: DEAN P 2/1/1999 SHEET 1 OF 2

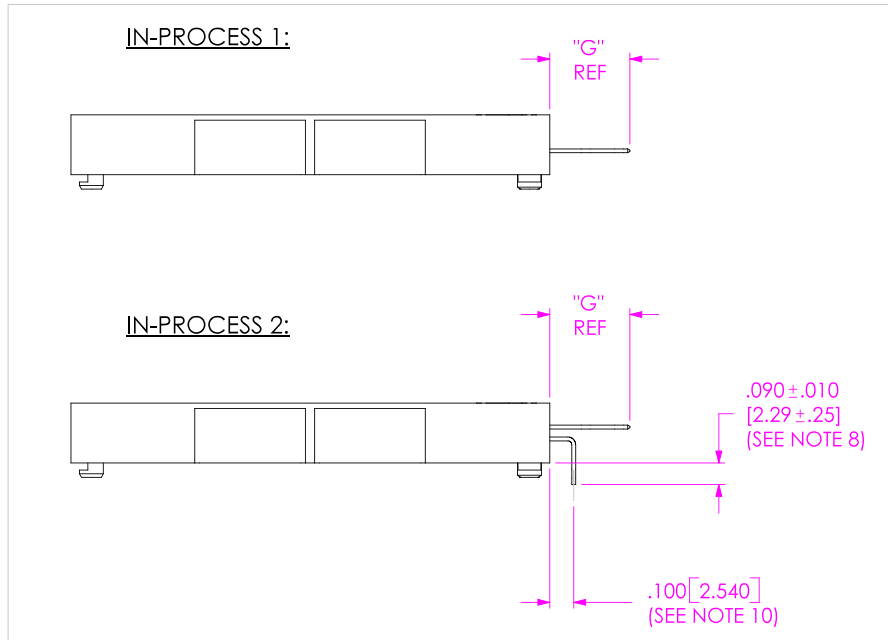

POST ("C")	"G"
.120 [3.05]	.680 [17.27]
.138 [3.51]	.662 [16.81]
.167 [4.21]	.633 [16.08]
.197 [5.00]	.603 [15.32]

PACKAGING VIEW

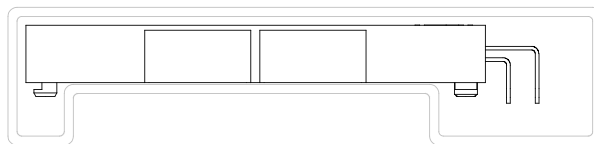

CARD LENGTH	TUBE	PLUG
-01	PT-1-24-01-81	TP-07
-02	PT-1-24-02-81	TP-07
-03	PT-1-24-03-81	2 TP-07 (per side)

FIG. 6

STYLE -01, -RA SHOWN

[DIFFERENT AS SHOWN, OTHERWISE SAME AS FIG. 1]

PROPRIETARY NOTE
 THIS DOCUMENT CONTAINS INFORMATION CONFIDENTIAL AND PROPRIETARY TO SAMTEC, INC. AND SHALL NOT BE REPRODUCED OR TRANSFERRED TO OTHER DOCUMENTS OR DISCLOSED TO OTHERS OR USED FOR ANY PURPOSE OTHER THAN THAT WHICH IT WAS OBTAINED WITHOUT THE EXPRESSED WRITTEN CONSENT OF SAMTEC, INC.

DO NOT SCALE DRAWING

SHEET SCALE: 1:2:1

SAMTEC

520 Park East Blvd. New Albany, IN 47151
 Phone (812) 944-6733 Fax (812) 948-5047
 e-Mail: INFO@SAMTEC.COM CODE: 55322

DESCRIPTION:
 .050 [1.27] CARD GUIDE ASSEMBLY

DWG. NO.
 PCMT-1XX-XX-X-D-RA-XX-SL-XX

BY: DEAN P 2/1/1999 SHEET 2 OF 2