

PRODUCT DATA DRAWING

REVISION HISTORY			
REV	DESCRIPTION	DATE	APPROVED
-	DCN 40101	10/13	STW

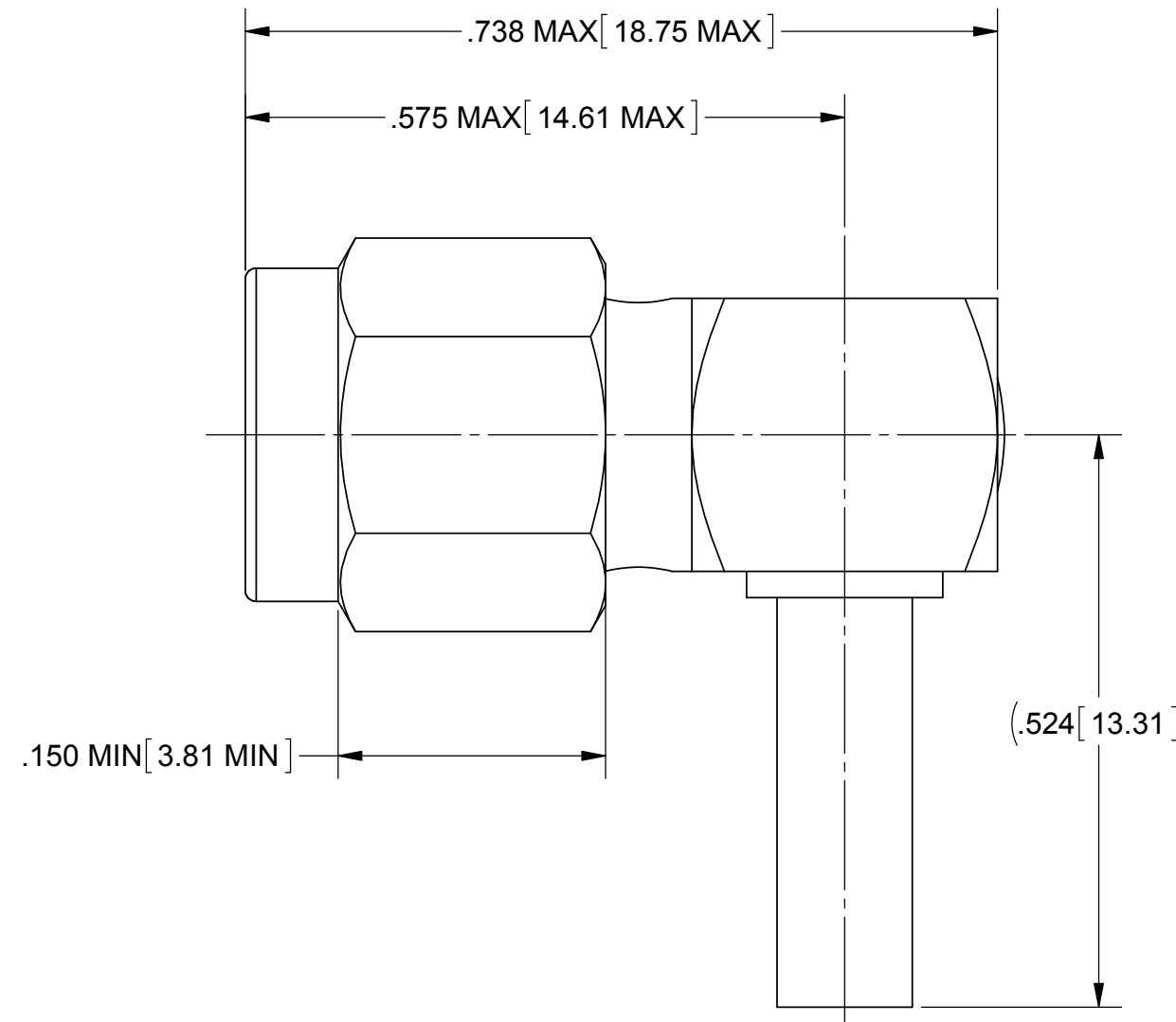
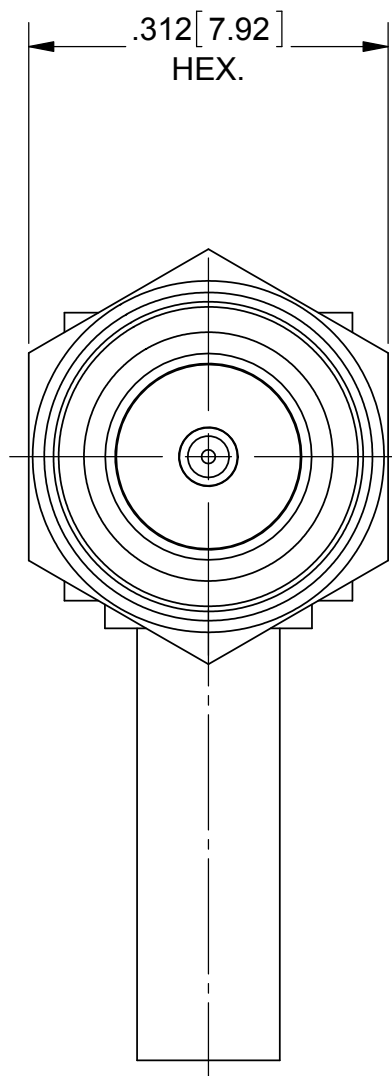

MATERIAL:

BODY & COUPLING NUT:

STAINLESS STEEL PER AMS-5640, ALLOY UNS S30300, TYPE 1

LOCK RING

BERYLLIUM COPPER PER ASTM B196, ALLOY No. UNS C17300, TD04

CONTACT & CRIMP RING:

BRASS PER ASTM B16, ALLOY UNS No. C36000

INSULATOR:

PTFE PER ASTM D1710, TYPE I, GRADE 1, CLASS B

GASKET:

SILICONE RUBBER PER A-A-59588, CLASS 2B, GRADE 50/60

PRESS CAP:

304 STAINLESS STEEL

SHRINK TUBING (NOT SHOWN):

FLEXIBLE POLYOLEFIN

FINISH:

BODY, PRESS CAP & COUPLING NUT:

PASSIVATED PER AMS-2700.

CONTACT:

GOLD PER ASTM B488, TYPE II, CODE C, CLASS 1.27, OVER NICKEL PER AMS-QQ-N-290, CLASS 1, .00005" MIN.

CRIMP RING:

NICKEL PER QQ-N-290, .00005" MIN.

PERFORMANCE:

IMPEDANCE:
FREQ. RANGE:
VSWR:

50 OHMS
DC TO 12.4 GHz
1.20 + .03F(F IN GHz), 0.5 TO 12.4 GHz
OR APPROXIMATELY 80% OF THE CUT OFF FREQUENCY OF THE CABLE, WHICHEVER IS LOWER

MATERIAL: SEE NOTES	DIMENSIONS ARE IN INCHES TOLERANCES: FRACTIONAL: ±1/64 ANGULAR: X° ±1'0" X'X' ±15'	UNLESS OTHERWISE SPECIFIED 1) ALL DIMENSIONS ARE IN INCHES (MILLIMETERS) 2) ALL DIMENSIONS ARE AFTER PLATING. 3) BREAK CORNERS & EDGES .005 R. MAX. 4) CHAM. 1ST & LAST THREADS. 5) SURFACE ROUGHNESS 63-MIL-STD-10. 6) DIA.'S ON COMMON CENTERS TO BE CONCENTRIC WITHIN .005 T.I.R. 7) REMOVE ALL BURRS	SV Microwave, Inc. 2400 Centrepark West Drive, Suite 100 West Palm Beach, FL 33409
FINISH: SEE NOTES	DECIMAL: X ±.030 .XX ±.010 .XXX ±.005	INTERPRET DIMENSIONS AND TOLERANCES PER ASME Y14.5M - 1994	TITLE: SMA PLUG R/A CRIMP ATTACHMENT FOR RG-178 CABLE
SURFACE AREA: N/A	THIRD ANGLE PROJECTION	DRAWN: FSG 10/03/13 CHECKED: STW 10/03/13 APPROVED: STW 10/03/13	SIZE: B CAGE CODE: 95077 DWG. NO.: M39012/56-3125
<p>PROPRIETARY</p> <p>THE INFORMATION CONTAINED IN THIS DRAWING IS THE SOLE PROPERTY OF SV MICROWAVE, INC. ANY REPRODUCTION IN PART OR AS A WHOLE WITHOUT THE WRITTEN PERMISSION OF SV MICROWAVE, INC IS PROHIBITED.</p>		SCALE: 4:1	SHEET 1 OF 1