

THIS DRAWING IS UNPUBLISHED. RELEASED FOR PUBLICATION, 19 .
 © COPYRIGHT 19 BY AMP INCORPORATED. ALL INTERNATIONAL RIGHTS RESERVED.

LOC	DIST	P	F	REVISIONS			DATE	APPD
ZONE	LTR	DESCRIPTION						
G	14			D	REV, RDRW, & SM PKG PER 0720-0061-93	4-16-93	APP DAP	

METRIC
 DIMENSIONS LISTED IN mm [INCHES]

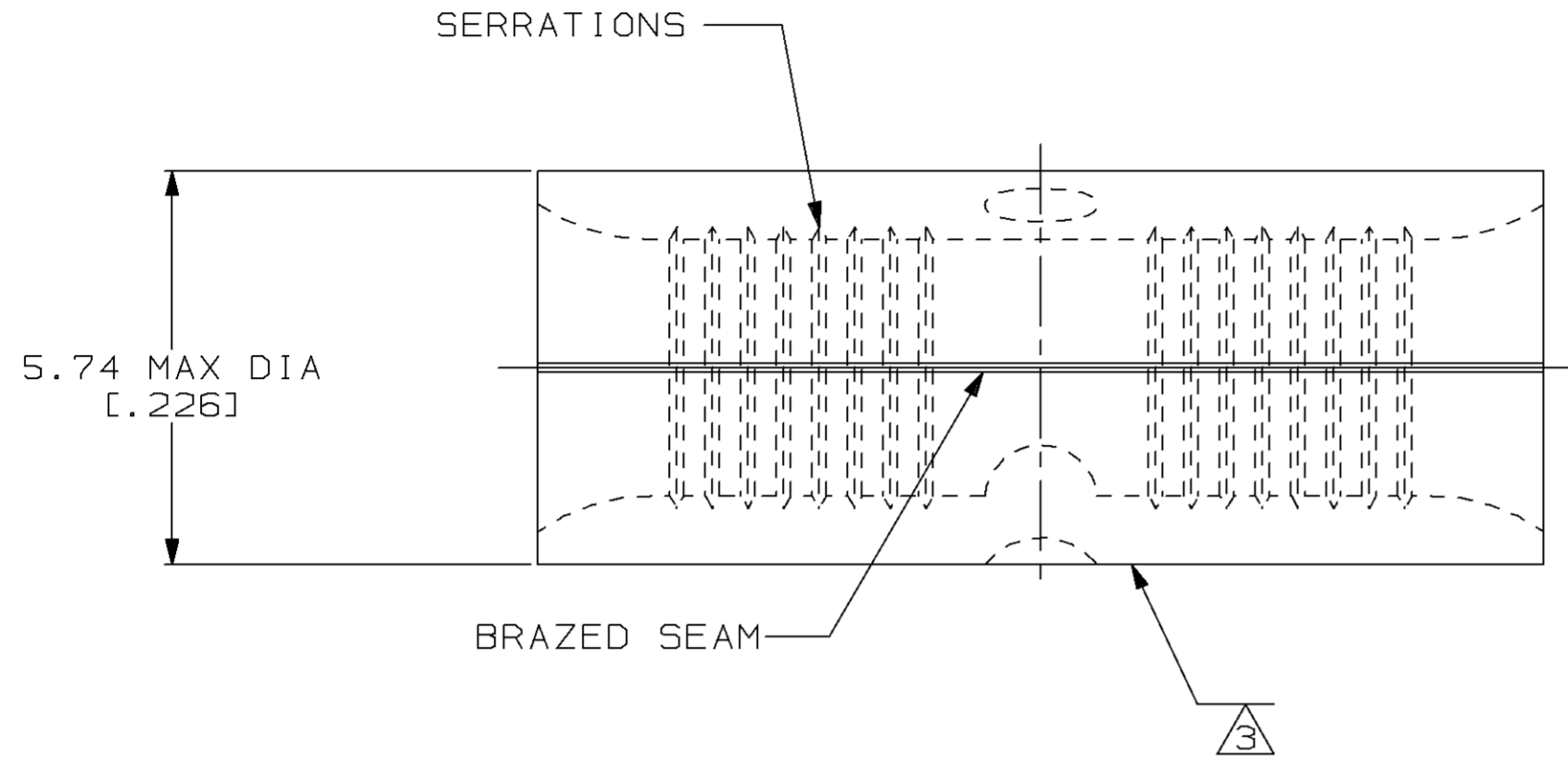

AMP WIRE RANGE	UL E13288 Listed
12-10 AWG SOLID OR STRANDED	NOT APPLICABLE
SR LR7189 Certified	MILITARY P/N AND CLASS
NOT APPLICABLE	NOT APPLICABLE

- ① STAMP AMP 12-10 APPROX AS SHOWN
- ② MAXIMUM LENGTH DOES NOT INCLUDE MANUFACTURING TABS
- ③ WIRE BARREL COLOR CODED ORANGE TO DENOTE NICKEL MATERIAL

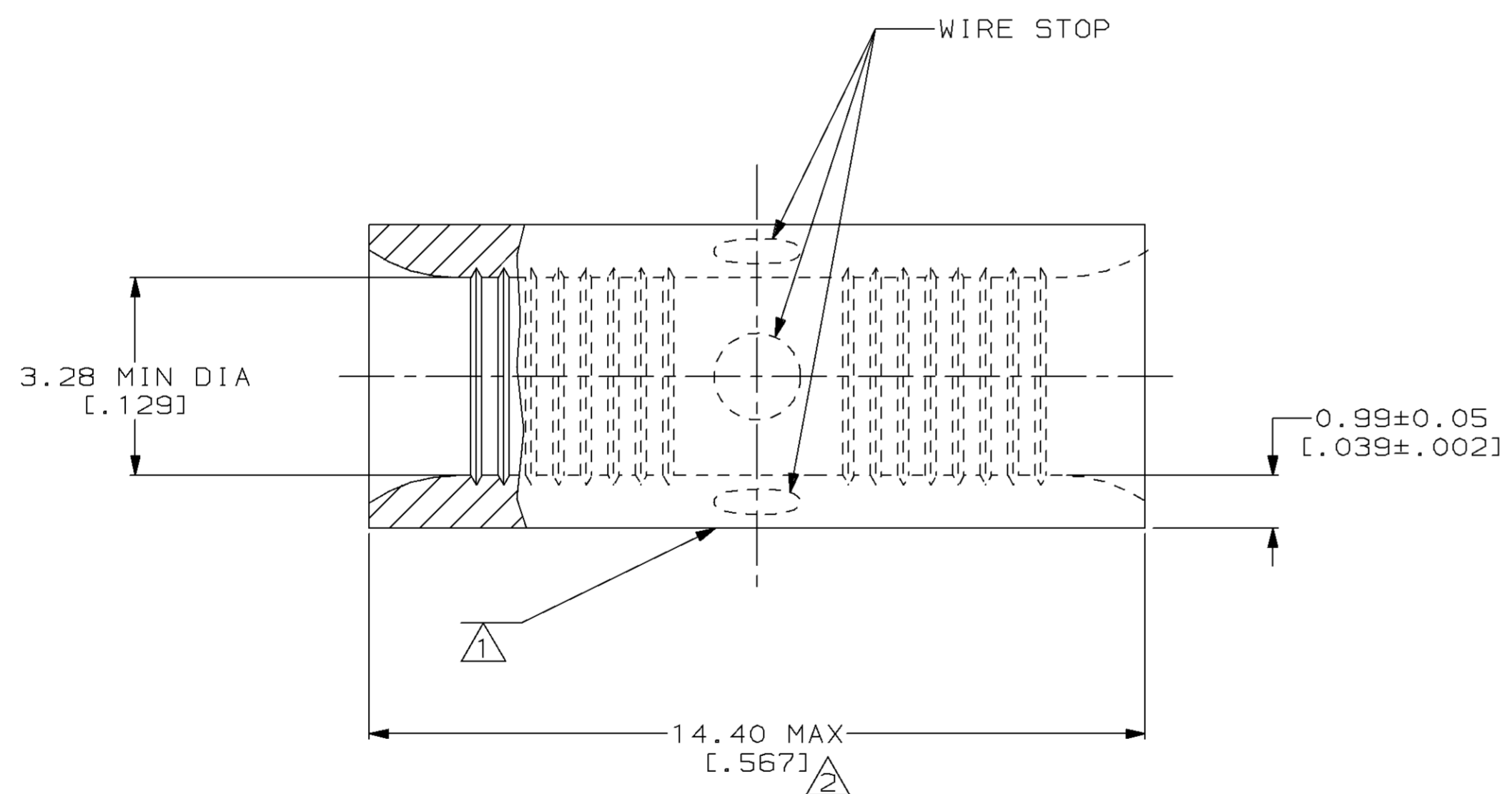

50	LOOSE PIECE, BOX	8-323696-2
----	LOOSE PIECE	323696
QUANTITY	PACKAGE TYPE	PART NO

AMP INCORPORATED
CUSTOMER SERVICE SYSTEMS

FOR ADDITIONAL PRODUCT INFORMATION OR COPIES OF DRAWINGS AND TECHNICAL DOCUMENTS

PRODUCT INFORMATION CENTER
 1-800-522-6752

FOR APPLICATION TOOLING INFORMATION

TOOLING ASSISTANCE CENTER
 1-800-722-1111

FOR ORDER ENTRY

1-800-526-5142

MAX RECOMMENDED OPERATING TEMPERATURE:
 649°C MAX

VOLTAGE RATING:
 NOT APPLICABLE

WIRE CROSS SECTIONAL AREA RANGE:
 2.62-6.64mm² [5,180-13,100] CIR MILS
 SOLID OR STRANDED

THIS DRAWING IS A CONTROLLED DOCUMENT FOR AMP INCORPORATED. IT IS SUBJECT TO CHANGE AND THE CONTROLLING ENGINEERING ORGANIZATION SHOULD BE CONTACTED FOR THE LATEST REVISION.

DO NOT SCALE PRINT. UNLESS SPECIFIED DIMENSIONS IN mm [INCHES]— TOLERANCES ON:

2 PLC DEC ± -
 3 PLC DEC ± -
 ANGLES ± -

MATERIAL
 NICKEL PER ASTM B-162 ANNEALED

FINISH
 -

DR 4-16-93
 TA BRINKMAN

CHK 4-16-93
 DA PATTERSON

APPD 4-16-93
 DE MILLER

APPD 4-16-93
 JL MECKLEY

PRODUCT SPEC
 -

APPLICATION SPEC
 -

WEIGHT
 -

AMP AMP Incorporated
 Harrisburg, PA 17105-3608

NAME
 SPLICE, BUTT, STANDARD,
 HIGH TEMPERATURE,
 STRATO-THERM™

SIZE
 © 00779

CAGE CODE
 ©=323696

DRAWING NO
 ©=323696

SCALE 10:1

SHEET 1 OF 1