

| PART NUMBER | REV | FIRST USED |
|-------------|-----|------------|
| 680169-1    | A   | 122500-1   |
| 680169-2    | A   | 565435-5   |

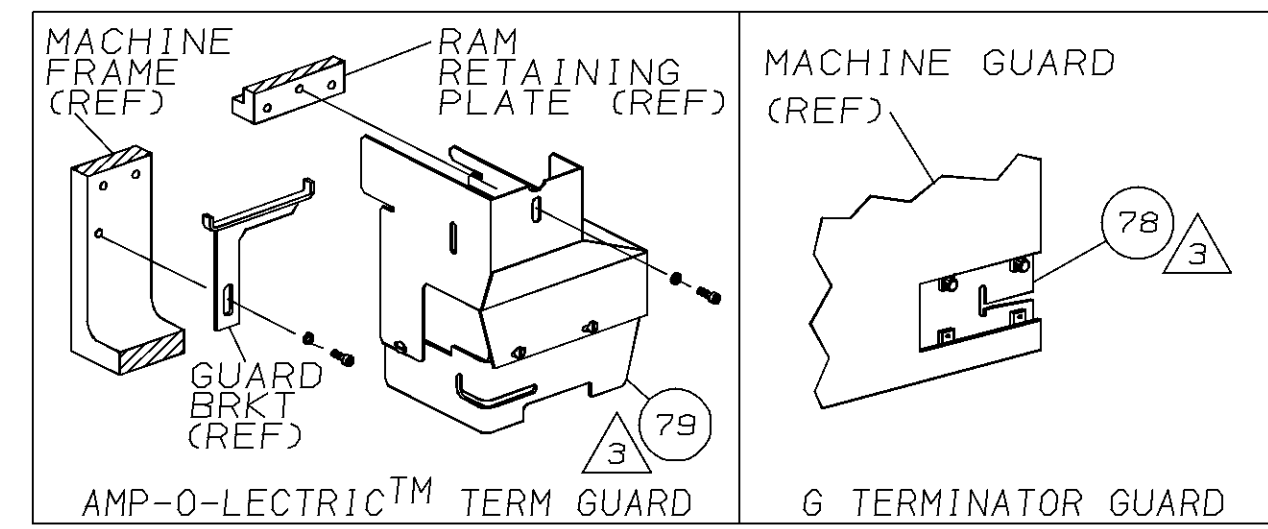

| TERMINAL NAME: .250 SERIES FASTIN-ON RECEPTAL |                           |                   |                                      |
|---|---------------------------|-------------------|--------------------------------------|
| 160811  |                           |                   |                                      |
| CRIMPING DATA                                 |                           |                   |                                      |
| PAD LTR                                       | CRIMP HEIGHT              | WIRE SIZE         |                                      |
| A   | .104 ±.002 [2.63 ±0.05mm] | 6 mm <sup>2</sup> |                                      |
| B   | .096 ±.002 [2.44 ±0.05mm] | 5 mm <sup>2</sup> |                                      |
| C   | .088 ±.002 [2.25 ±0.05mm] | 4 mm <sup>2</sup> |                                      |
| D   | NOT                       | USED              |                                      |
| CRIMP   | SIZE                      | TYPE              | RANGE                                |
| WIRE  | .160 [4.06mm]             | F                 | 4 mm <sup>2</sup> -6 mm <sup>2</sup> |
| INSUL   | .210 [5.33mm]             | 0                 | 3.4mm-5.1mm                          |
| WIRE STRIP LENGTH                             | TERM APPL                 | SPEC              | FEED                                 |
| -   | -                         | -                 | .845                                 |
| APPL INSTRUCTION                              |                           | SET UP GAGE       | LAYOUT                               |
| 408-8039                                      |                           | 458638-1          | L1650                                |

| LEADMAKER & BENCH MODEL G |     | MECH POST FEED |   |            |                              |    |
|---------------------------|-----|----------------|---|------------|------------------------------|----|
| BENCH MODEL K             |     | MECH POST FEED |   |            |                              |    |
| REF                       | REF | -              | A | 22594-8    | NUT, HEX                     | 70 |
| REF                       | REF | -              | B | 240628-1   | PLATE, ADJ                   | 69 |
| REF                       | REF | -              | B | 240626-1   | SHAFT, PIVOT                 | 68 |
| REF                       | REF | -              | B | 240633-1   | BUSHING                      | 67 |
| REF                       | REF | -              | A | 455680-1   | LEVER, INTERMEDIATE          | 66 |
| REF                       | REF | -              | B | 240629-1   | BLOCK, PIVOT                 | 65 |
| REF                       | REF | -              | A | 240632-2   | SCR, ADJ                     | 64 |
| REF                       | REF | -              | B | 240659-3   | PIN, CAM ROLLER              | 63 |
| REF                       | REF | -              | B | 240658-1   | CAM, ROLLER                  | 62 |
| REF                       | REF | -              | B | 454398-1   | ROD, FEED                    | 61 |
|                           |     |                |   |            |                              | 60 |
| REF                       | REF | -              | C | 454220-1   | CAP, RAM                     | 59 |
| REF                       | REF | -              | D | 453736-1   | HOUSING                      | 58 |
|                           |     |                |   |            |                              | 57 |
|                           |     |                |   |            |                              | 56 |
| REF                       | REF | -              | B | 240624-1   | PIN, FEED FINGER             | 55 |
| REF                       | REF | -              | B | 691499-1   | SPRING, FEED FINGER          | 54 |
| REF                       | REF | -              | B | 240635-1   | FINGER, FEED                 | 53 |
| REF                       | REF | -              | B | 240634-3   | LEVER, TERMINAL              | 52 |
|                           |     |                |   |            |                              | 51 |
|                           |     |                |   |            |                              | 50 |
|                           |     |                |   |            |                              | 49 |
| 1                         | -   | -              | B | 690501-3   | CAM, POST FEED 1 1/8 ST      | 48 |
| -                         | 1   | -              | B | 690501-4   | CAM, POST-FEED 1 5/8 ST      | 47 |
|                           |     |                |   |            |                              | 46 |
| 1                         | 1   | -              | A | 690191-1   | PLUG, NYLON                  | 45 |
| 1                         | 1   | -              | C | 455674-1   | RAM                          | 44 |
| 1                         | 1   | -              | A | 690125-1   | WASHER, LAMINATED            | 43 |
| 1                         | 1   | -              | A | 690124-1   | WASHER, RAM                  | 42 |
| 1                         | 1   | -              | A | 7-21002-9  | BOLT, CRIMPER (5/16-24x1.00) | 41 |
| 1                         | 1   | -              | A | 23241-6    | BALL, STEEL                  | 40 |
| 1                         | 1   | -              | A | 690170-1   | SPRING, COMPRESSION          | 39 |
| 1                         | 1   | -              | C | 690142-1   | DISC, INSULATION             | 38 |
| 1                         | 1   | -              | D | 354777-1   | WIRE DISC, PLASTIC           | 37 |
| 1                         | 1   | -              | A | 22480-5    | WASHER, SPRING               | 36 |
| 1                         | 1   | -              | B | 690212-1   | POST, RAM                    | 35 |
|                           |     |                |   |            |                              | 34 |
|                           |     |                |   |            |                              | 33 |
| 1                         | 1   | -              | D | 458980-2   | APPLICATOR, BASIC (SUB ASSY) | 32 |
|                           |     |                |   |            |                              | 31 |
|                           |     |                |   |            |                              | 30 |
|                           |     |                |   |            |                              | 29 |
|                           |     |                |   |            |                              | 28 |
| 1                         | 1   | -              | A | 690455-3   | STRIPPER                     | 27 |
| REF                       | REF | -              | C | 455676-1   | PLATE, BASE                  | 26 |
| 2                         | 2   | -              | A | 22354-8    | DRAG, STUD                   | 25 |
| 1                         | 1   | -              | B | 458803-5   | PLATE, STRIP GUIDE           | 24 |
| 1                         | 1   | -              | C | 240825-2   | PLATE, STRIP HOLD DOWN       | 23 |
| 2                         | 2   | -              | A | 4-22281-1  | SPRING, DRAG                 | 22 |
|                           |     |                |   |            |                              | 21 |
| 1                         | 1   | -              | A | 454177-1   | DRAG, STOCK                  | 20 |
|                           |     |                |   |            |                              | 19 |
| 2                         | 2   | -              | C | 1-454204-0 | GUIDE, STRIP (FRONT)         | 18 |
| REF                       | REF | -              | A | 454178-1   | GUIDE, FEED ROD              | 17 |
| REF                       | REF | -              | A | 4-22284-9  | SPRING, FEED RETURN          | 16 |
|                           |     |                |   |            |                              | 15 |
|                           |     |                |   |            |                              | 14 |
| 1                         | 1   | -              | C | 690481-2   | SPACER, HOLD DOWN            | 13 |
| 1                         | 1   | -              | A | 23846-1    | SPRING, HOLD DOWN            | 12 |
| 1                         | 1   | -              | B | 240833-2   | PLATE, REAR SHEAR            | 11 |
|                           |     |                |   |            |                              | 10 |
| 1                         | 1   | -              | B | 690482-3   | PLATE, FRONT SHEAR           | 9  |
| 1                         | 1   | -              | D | 9-683452-3 | ANVIL                        | 8  |
| 1                         | 1   | -              | B | 690474-3   | BLADE, SLUG                  | 7  |
| 1                         | 1   | -              | D | 2-455892-7 | HOLD DOWN, TERMINAL          | 6  |
| 1                         | 1   | -              | C | 6-240641-9 | SPACER, SLUG BLADE           | 5  |
| 1                         | 1   | -              | B | 2-238009-5 | SPACER, BLOCK CRIMPER        | 4  |
| 1                         | 1   | -              | C | 854830-4   | CRIMPER, INSULATION          | 3  |
| 1                         | 1   | -              | B | 1-455888-3 | SPACER, CRIMPER              | 2  |
| 1                         | 1   | -              | C | 456414-1   | CRIMPER, WIRE                | 1  |

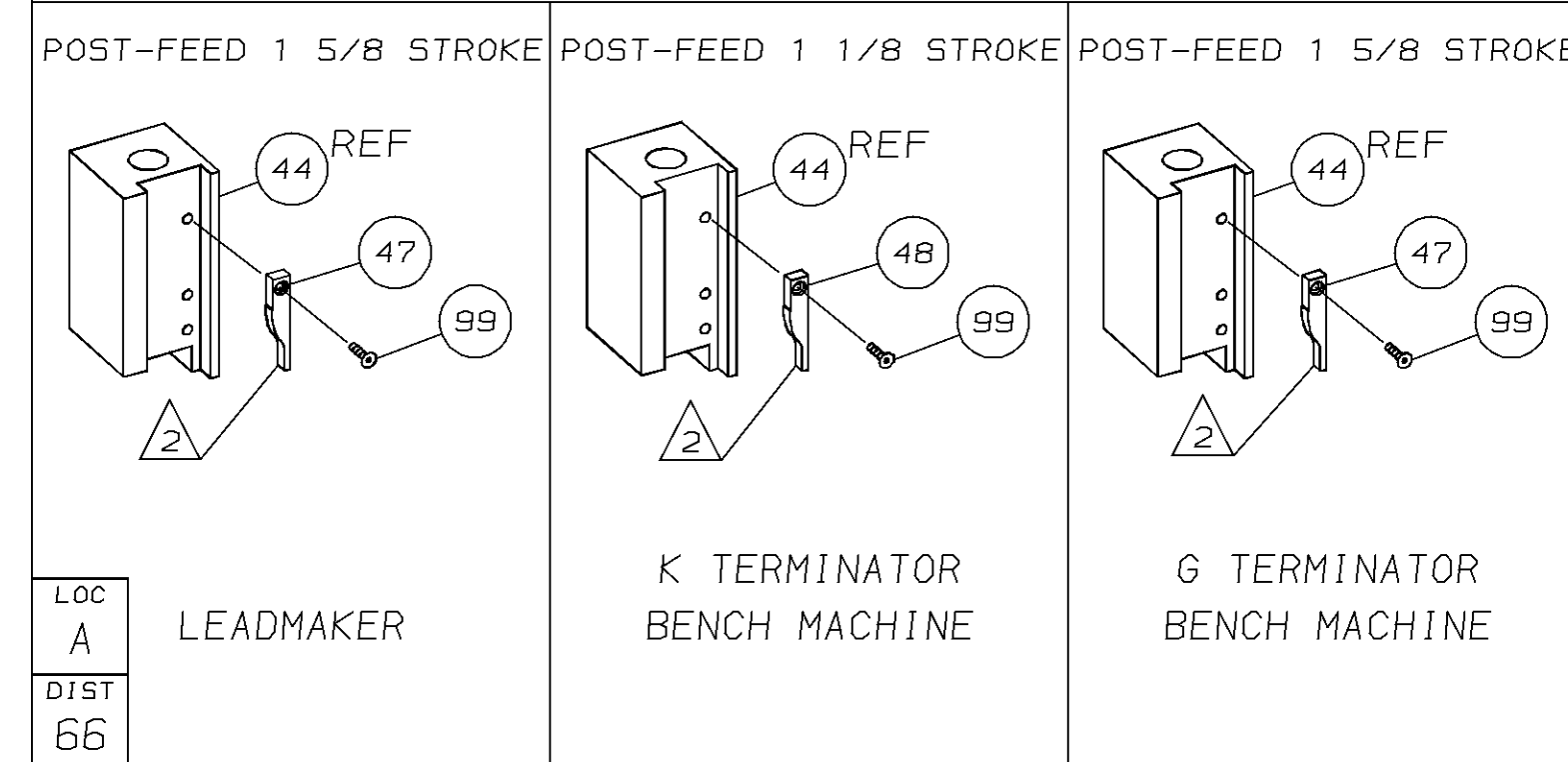
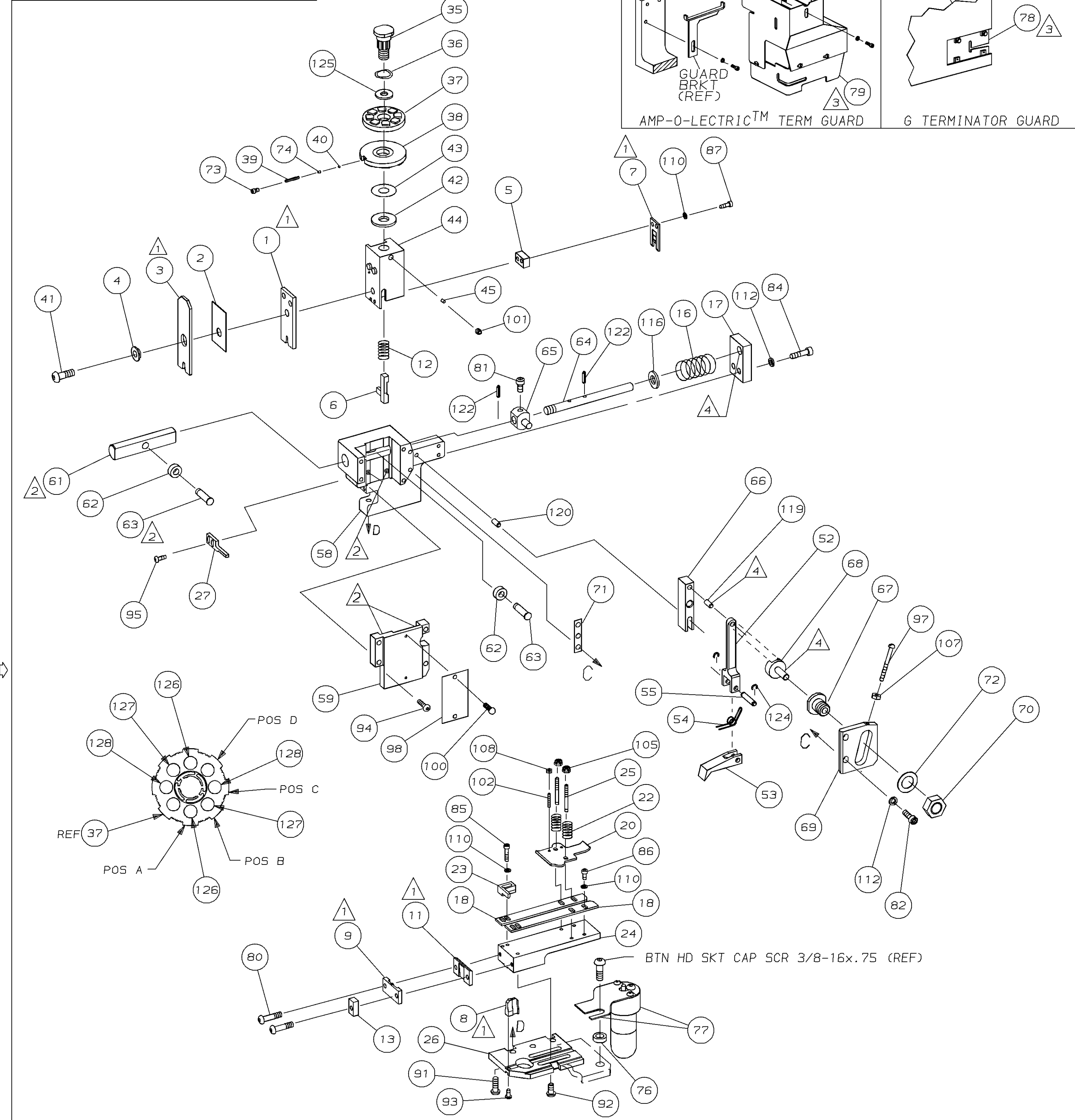

- 1 RECOMMENDED SPARE PARTS.
- 2 GREASE LIGHTLY.
- 3 GUARD MUST BE IN PLACE WHEN OPERATING APPLICATOR IN A BENCH MACHINE.
- 4 LUBRICATE DAILY USING NO. 20 MACHINE OIL.
- 5. ITEMS WITH QTY OF REF SPECIFIED (EXCEPT ITEMS 78 AND 79) ARE USED ON ITEM 32.
- 6 ITEM 78 USED WITH G TERMINATOR ONLY.
- 7 SILVER PLATED TERMINALS REQUIRE LUBRICATION.

| QTY | REF | U/M | DWG SIZE | PART NO    | DESCRIPTION                      | ITEM NO |
|-----|-----|-----|----------|------------|----------------------------------|---------|
| 2   | 2   | -   | C        | 6-354778-4 | PIN, WIRE DISC (.2815)C          | 129     |
| 2   | 2   | -   | C        | 4-354778-7 | PIN, WIRE DISC (.2730)B          | 127     |
| 2   | 2   | -   | C        | 2-354778-7 | PIN, WIRE DISC (.2630)A          | 126     |
| 1   | 1   | -   | A        | 986950-1   | WASHER, FLAT PRECISION           | 125     |
| REF | REF | -   | A        | 21045-3    | RING, RET "C" (Ø.187)FD PIN      | 124     |
|     |     |     |          |            |                                  | 123     |
| REF | REF | -   | A        | 5-21028-1  | PIN, STD SPRING (Ø.12)FD ADJ ROD | 122     |
|     |     |     |          |            |                                  | 121     |
| REF | REF | -   | A        | 1-21030-7  | PIN, DOWEL (Ø.187x1.50)HSG       | 120     |
| REF | REF | -   | A        | 1-21030-1  | PIN, DOWEL (Ø.187x.50)LEVER      | 119     |
|     |     |     |          |            |                                  | 118     |
|     |     |     |          |            |                                  | 117     |
| REF | REF | -   | A        | 21899-4    | WASHER, FLAT (Ø5/16)SCR ADJ      | 116     |
|     |     |     |          |            |                                  | 115     |
|     |     |     |          |            |                                  | 114     |
| REF | REF | -   | A        | 21024-5    | WASHER, LOCK (NO.10)FD ROD GDE   | 113     |
|     |     |     |          |            |                                  | 112     |
| 7   | 7   | -   | A        | 21024-4    | WASHER, LOCK (NO.8)SHEAR BL      | 110     |
|     |     |     |          |            |                                  | 109     |
| 2   | 2   | -   | A        | 21018-4    | NUT, HEX (4-40)DRAG              | 108     |
| REF | REF | -   | A        | 21018-5    | NUT, HEX (6-32)FD ADJ PL         | 107     |
|     |     |     |          |            |                                  | 106     |
| 2   | 2   | -   | A        | 21022-2    | NUT, HEX SL (8-32)DRAG STUD      | 105     |
|     |     |     |          |            |                                  | 104     |
|     |     |     |          |            |                                  | 103     |
| 2   | 2   | -   | A        | 2-21006-6  | SCR, SKT SET (4-40x.62)DRAG      | 102     |
| 1   | 1   | -   | A        | 21009-2    | SCR, SKT SET (1/4-20x.25 )RAM    | 101     |
| 2   | 2   | -   | A        | 21017-2    | SCR, DRIVE (#2x.19)ID PLATE      | 100     |
| 1   | 1   | -   | A        | 1-21002-7  | SCR, BHC (6-32x.38)CAM           | 99      |
| 1   | 1   | -   | B        | 461264-1   | PLATE, IDENTIFICATION            | 98      |
| REF | REF | -   | A        | 6-23715-5  | SCR, PAN HD (6-32x1.50)FEED ADJ  | 97      |
|     |     |     |          |            |                                  | 96      |
| 2   | 2   | -   | A        | 2-21002-2  | SCR, BHC (8-32x.50)STRIPPER      | 95      |
| REF | REF | -   | A        | 2-21002-9  | SCR, BHC (10-32x.75)HSG CAP      | 94      |
| 1   | 1   | -   | A        | 22733-8    | SCR, BHC (8-32x.38 LW)ANVIL      | 93      |
| 4   | 4   | -   | A        | 3-21002-3  | SCR, BHC (1/4-20x.50)ST ØD PL    | 92      |
| REF | REF | -   | A        | 2-22733-8  | SCR, BHC (1/4-20x.62)BASE PL     | 91      |
|     |     |     |          |            |                                  | 90      |
|     |     |     |          |            |                                  | 89      |
|     |     |     |          |            |                                  | 88      |
| 2   | 2   | -   | A        | 2-21000-7  | SCR, SHC (8-32x.50)SLUG BLADE    | 87      |
| 3   | 3   | -   | A        | 2-21000-6  | SCR, SHC (8-32x.38)STRIP GUIDE   | 86      |
| 2   | 2   | -   | A        | 2-21000-9  | SCR, SHC (8-32x.75)R STRIP GUIDE | 85      |
| REF | REF | -   | A        | 3-21000-7  | SCR, SHC (10-32x.75)FEED ROD GDE | 84      |
|     |     |     |          |            |                                  | 83      |
| REF | REF | -   | A        | 3-21000-6  | SCR, SHC (10-32x.62)FEED ADJ PL  | 82      |
| REF | REF | -   | A        | 3-21000-4  | SCR, SHC (10-32x.38)PIVOT BLOCK  | 81      |
| 2   | 2   | -   | A        | 3-21002-0  | SCR, BHC (10-32x.88)SHEAR PL     | 80      |
| REF | -   | -   | A        | 455745-1   | GUARD, WINDOW                    | 79      |
| -   | REF | -   | A        | 679532-1   | INSERT, GUARD                    | 78      |
| 1   | -   | -   | C        | 465184-9   | LUBRICATOR ASSY                  | 77      |
| 1   | -   | -   | A        | 454406-1   | SPACER, LUB BRACKET              | 76      |
|     |     |     |          |            |                                  | 75      |
| 1   | 1   | -   | A        | 690603-1   | SPRING, ASSIST                   | 74      |
| 1   | 1   | -   | A        | 23030-1    | SCR, SKT CAP (6-32x.25)CP DSC    | 73      |
| REF | REF | -   | A        | 458109-1   | WASHER, FLAT (SPECIAL)           | 72      |
| REF | REF | -   | A        | 690517-1   | SPACER                           | 71      |

| QTY             | REF     | U/M | DWG SIZE | PART NO | DESCRIPTION | ITEM NO |
|-----------------|---------|-----|----------|---------|-------------|---------|
| -2              | -1      | U/M |          |         |             |         |
| PARTS LIST      |         |     |          |         |             |         |
| REVISION RECORD |         |     |          |         |             |         |
| A               | REVISED | CE  | 7/95     |         |             |         |
| P               | REVISED | APP |          |         |             |         |
| F               | REVISED |     |          |         |             |         |
| L               | REVISED |     |          |         |             |         |
| T               | REVISED |     |          |         |             |         |

| DIMENSIONS IN INCHES. DO NOT SCALE PRINT. TOLERANCES UNLESS OTHERWISE SPECIFIED. |         |                | REVISION OF EACH ASSY NO (WHEN BLANK, USE DWG REVISION) |  |  |
|--|---------|----------------|---|--|--|
| MATL   | HT TR   | FIN            |   |  |  |
| DR B. HIGMAN   | 5/25/95 | APP T. BEDDICK | 5/25/95   |  |  |
| CHK C. ERISMAN   | 5/25/95 | REL G. OCHENIS | 8/30/95   |  |  |
| NAME: END FEED HDM APPLICATOR  |         |                | MACHINE REF: MINI APPL                                  |  |  |
| SCALE: -   |         |                | SHEET: 1 OF 1   |  |  |
| DWG NO: 680169   |         |                | REV: A  |  |  |

THIS DRAWING IS A CONTROLLED DOCUMENT FOR AMP INCORPORATED. IT IS SUBJECT TO CHANGE AND THE CONTROLLING ENGINEERING ORGANIZATION SHOULD BE CONTACTED FOR THE LATEST REVISION.

THIS INFORMATION IS CONFIDENTIAL AND IS DISCLOSED TO YOU ON CONDITION THAT NO FURTHER DISCLOSURE IS MADE BY YOU TO OTHER THAN AMP PERSONNEL WITHOUT WRITTEN AUTHORIZATION FROM AMP INCORPORATED, HARRISBURG, PA.