

Industrial Networking

This section describes the data and command exchange communications options available for CJ1 systems:

Need to exchange large volumes of large messages enterprise-wide?

Ethernet

Page B-79

Need a deterministic network between PLCs and between computers and PLCs?

Controller Link

Page B-83

Need an open network that exchanges device data and status?

DeviceNet
Slave I/O and DeviceNet-communicating Omron controls

Page B-88

Need a high speed, open network that exchanges data between automation control systems and distributed I/O at the device level?

Profibus-DP

Page B-95

Need a high-speed distributed I/O network?

CompoBus/S
Wide range of slave I/O options

Page B-97

Need to exchange data and make remote settings available to host computers, controllers and other serial devices?

Serial Communications
Protocol Macros allow immediate connectivity to serial controllers, offer custom protocol development and ladder program access

Page B-101

Collect and Share Valuable Data

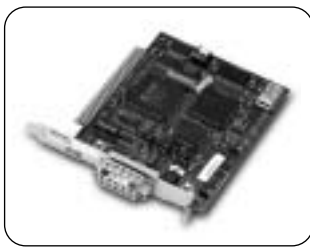

Networking has become one of the core requirements of automation systems today because tomorrow's competitive edge comes from factory floor and enterprise-wide data. More and more, factory operations are becoming dependent on machine and line productivity data.

Automation systems that were once isolated and stand-alone now provide valuable data for process optimization and statistical analysis.

Omron's Industrial Networking options provide easy-to-implement connections from controllers to Data Acquisition Systems and Supervisory Control Systems that is unmatched in the industry today. This is very easy to accomplish using Omron's Programmable Controllers because:

- 1) the Communications Modules provide the intelligence for routing the commands or data, and
- 2) the memory of the processor is organized so that communications requests can access data areas in the processor without interrupting the control function of the CPU to do "block transfers."

Data memory provides a "scratch pad" for information to be written to and read from. It can also be the "working" memory to which real world I/O changes are automatically written. This allows the user to designate the desired data, what it means and what should be done with it from a remote location, *without* interfering with the execution of the control program.



The final key to this capability is Omron's unique middleware product called FINS (Factory Intelligent Network Service) that allows messages and information to be *seamlessly* routed across and up to three networks. This means that a message or command that originates from a computer and originates on Ethernet, can route through a factory floor Programmable Controller over Controller Link and, finally, access I/O data in a "micro" controller over either a serial link or DeviceNet.



Omron Simplifies Setup for Network Communications

Examine the realities and costs involved in building the network communications that let you integrate plant floor data with front office systems. Two considerations move to the top of the list: flexibility to handle changing requirements easily and the ability to integrate legacy products. The table below clarifies the advantages of Omron's approach.

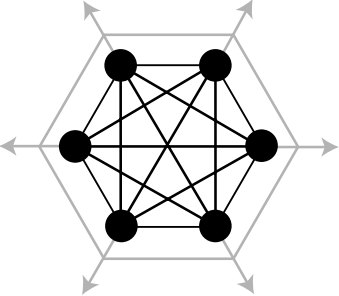
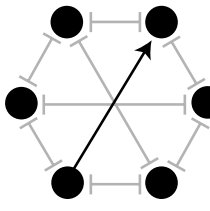
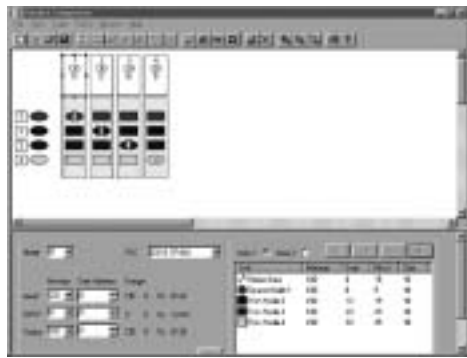
Comparison of Omron's Data Link to Traditional Block Transfer

Data Exchange Method	Data Link	Block Transfer
<p>What it accomplishes</p>	<p>Makes available an easily expanded area of data that is accessible to all PLCs on the network. Data requests are handled outside the scan time by co-processors in the communications modules.</p> 	<p>Defines a point-to-point connection between a desired individual data point in a PLC to make a specific link to the requesting PLC and define the amount of data that can be exchanged. Typically limited to 64 words.</p> 
<p>Setup procedure</p>	<ul style="list-style-type: none"> • Use dialog box "wizard" setup • User defines how much data is to be sent via the Data Link, what memory location is to be used and how much to "read" from all other network nodes 	<ul style="list-style-type: none"> • Use special Move instructions • Must follow any Read or Write command • Error checking is done by programming and data consistency must be checked due to scan cycle mismatches
<p>Setup example</p>	<p>The screen capture shows a typical Data Link set-up in progress. The user can define:</p> <ul style="list-style-type: none"> • How much data gets sent • What memory area is the source of the data and • Where to put received data 	<p>Printout shows the first rung of an extensive program required to define point-to-point data exchange and to verify data consistency.</p> <ul style="list-style-type: none"> • Error checking is done by programming • Size of transfer affects program cycle timing 
<p>Making changes</p>	<ul style="list-style-type: none"> • Amount of data to be handled, changing where it goes or adding a new node is as simple as the initial setup • No impact on program execution 	<ul style="list-style-type: none"> • Program must be adjusted if data size changes; program execution time changes • If different models are communicating, up to 3 programming software packages could be required
<p>Costs and future expandability</p>	<p>Data Link reduces the original cost of programming in setting up the routing tables for exchange and offers maximum flexibility for future changes, requiring minimal editing to routing table data.</p>	<p>Long hours of programming each individual point-to-point exchange followed by system testing to be sure cycle time is acceptable, followed by any modifications to bring cycle time back into bounds. Future changes are time consuming editing projects.</p>
<p>Handling legacy systems</p>	<p>Omron's CX-Programmer software covers all Omron's programmable controllers with networking capability, from micros up to large rack systems. Access to the memory areas available for each model is selected in a dialog box when the specific model is designated.</p>	<p>Depending on the manufacturer, multiple programming software packages are required to set up and modify the block transfer ladder programming across the full range of PLCs in an installation. Finding and hiring programmers with experience in older platforms becomes difficult as time goes by.</p>

Seamless Network Communications

Network Hierarchies Stretch from Field Component Networks to Top-Level Ethernet Networks

- Seamless Inter-network Communications Using FINS Commands
- Exceptional Multi-vendor Support

■ Networking Solutions

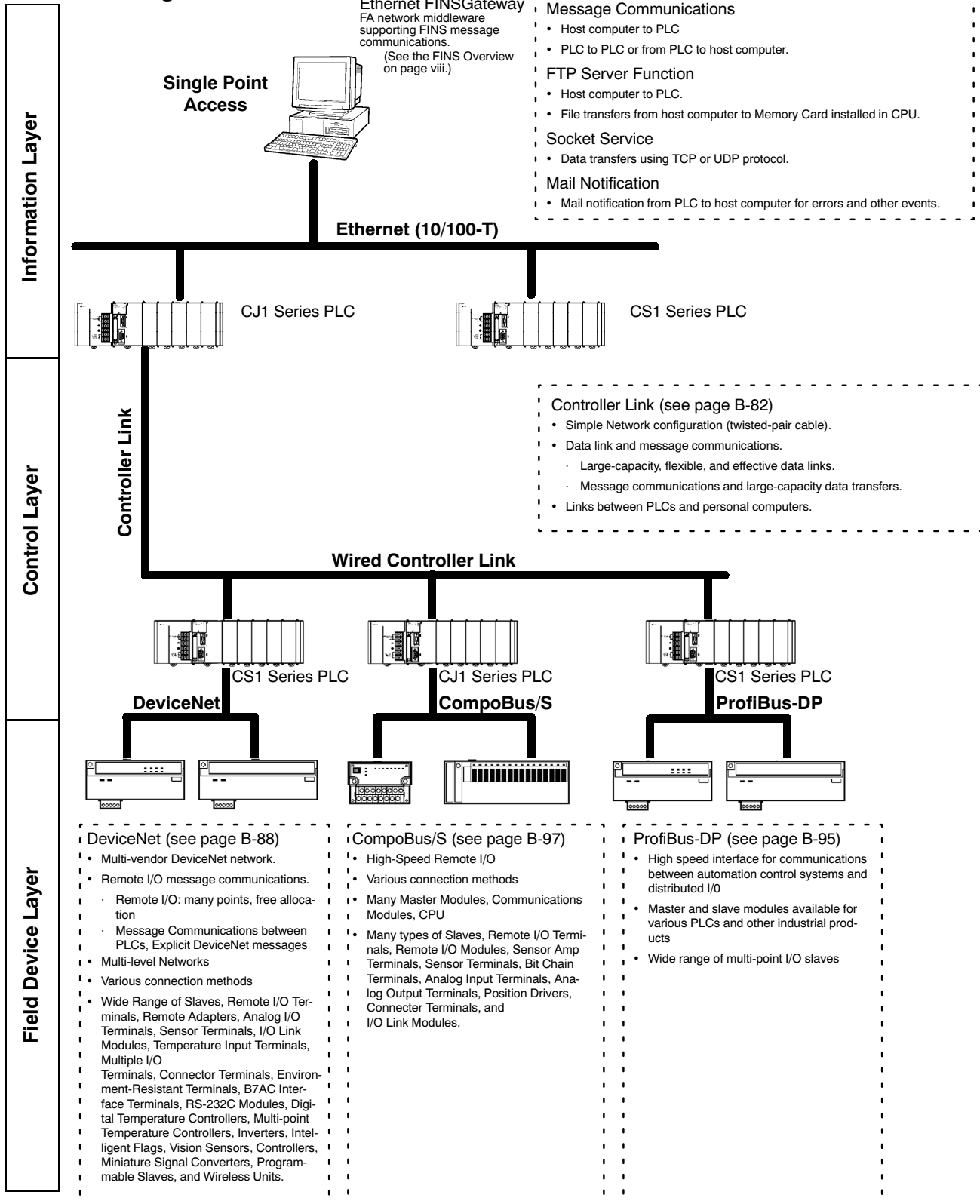

■ Overview

Level	Network	Functions	Communications	CPU Bus Module
Information networks	Ethernet	Host computer to PLC	FINS messages	Ethernet Module
		PLC to PLC		
		Host computer to CPU memory card	FTP server	
	UNIX computer or other socket service to PLC	Socket services SMTP (TCP/IP)		
Control networks	Controller Link	Computers connected directly to network and PLC	FINS messages	Controller Link Support Board and Module
			Data links (offsets and automatic setting)	
Control networks	Controller Link	PLC to PLC	FINS messages	Controller Link Module
			Data links (offsets and automatic setting)	
	DeviceNet		FINS messages on open network	DeviceNet Module and Configurator
Field device networks	DeviceNet	PLC to components (slaves)	High-capacity remote I/O on open network (fixed or user allocations)	DeviceNet Module and Configurator
	CompoBus/S		High-speed remote I/O (fixed allocation) on OMRON network.	CompoBus/S Master Module
	ProfiBus-DP		High-capacity remote I/O on open network (fixed or user allocations).	ProfiBus-DP Master and Configurator

■ Communications Specifications

Network	Ethernet (ETN21)	Controller Link (CLK21-V1)	DeviceNet (DRM21)	CompoBus/S (SRM)	ProfiBus-DP (PRM21)
Messages	Yes	Yes	Yes	—	Yes
Data links	—	Yes	—	—	—
Remote I/O	—	—	Yes	Yes	Yes
Maximum speed	10 Mbps Comm cycle: send and receive 156 words 166 ms	2 Mbps Comm cycle: Approx. 34 ms (Wired: 32 nodes, 2-Kbits + 2K word data links)	500 kbps Comm cycle: Approx. 5 ms (128 inputs and 128 outputs)	750 kbps (See note.) Comm cycle: Approx. 1 ms (128 inputs and 128 outputs)	12 Mbps Comm cycle: Approx. 1 ms
Total distance	2.5 km	Twisted-pair cable: 1.5 km max. using 2 repeater units (at 2 Mbps) -1 km max. without repeater units	500 m (at 125 bps)	Trunk line: 500 m (for the long-distance communications mode). Total wiring length is 200 m when using the 4-conductor VCTF cable or special flat cable. Communications cycle: 6 ms max.	1200 m at 9600 bps 100 m at 12 Mbps Up to 4800 m with 3 repeaters
Maximum nodes	254	62 when used with 2 repeater units and -V1 CLK units	63	32	125
Communications media	Unshielded twisted-pair cable using RJ45 modular connectors	Shielded twisted-pair cable Optical fiber cable	DeviceNet cable	2-conductor VCTF cable, 4-conductor VCTF cable, special flat cable (different cables cannot be used together)	Shielded twisted-pair
Network data link capacity	—	32,000	—	—	—
Remote I/O capacity	—	—	32,000 pts (with Configurator); 2,048 pts (without Configurator)	256 pts	4800 (with Configurator) 1600 (without Configurator)
Supporting PLCs	CJ1 Series, CS1 Series	CJ1 Series, CS1 Series	CJ1 Series, CS1 Series, CVM1, CV Series, C200HX/HG/HE, C200HS, C200HS, CQM1/CQM1H (with I/O Link)	CJ1 Series, CS1 Series, C200HX/HG/HE, C200HS, CQM1/CQM1H, CPM2C-S1□0C(-DR T), CPM1A (with I/O Link), CPM2C (with I/O Link)	CS1, CJ1, C200HX/HG/HE, C200HS, CQM1, CQM1H (with I/O link), CPM1A/2A (with I/O link)

Note: For the high-speed communications mode (trunk length: 100 m); 30 m max. when using 4-conductor VCTF cable or special flat cable.

Bridging the Internet and Front Office/Management Information Needs and Factory Floor Operations



CJ1W-ETN21
100BASE-TX, 10BASE-T Ethernet Module

Network Capabilities

Basic Capabilities

- Compatible with 100Base-TX (100 Mbps) and 10 Base-T (10 Mbps)
- 254 total nodes possible
- SNTP client functionality for automatic clock adjustment
- DNS client functionality to specify servers by host name
- Compatible with earlier CS1/CJ1 Ethernet modules

E-Mail Capability

- Transmit e-mail attachments from the Ethernet module using an SMTP server to acquire user-created data, error log data, and module status data.
- Using a POP3 server, the user can send commands to the Ethernet unit via e-mail.

Internet Capability

- Host computers that acquire a dynamic IP address (using DHCP) can send commands to the PLC and receive responses.
- Multiple FINS supported applications within the computer can go on-line simultaneously.
- Using FINS communications, both TCP/IP and UDP/IP are supported.
- Using the built-in FTP server, files can be read from or written to the mounted memory card.
- Using FINS communications, connectivity with devices on other networks is possible (renting services).
- Socket services (TCP or UDP protocols) allow for Ethernet connected devices to send and receive data.
- FINS commands can be sent or received by PLCs or computers on the same Ethernet network.

Specifications

Product	Communications services	Unit numbers	Model number
CPU Bus Module	FINS communications, FTP server, socket services, DNS client, Mail services, SNTP services.	0 to F (4 modules max.)	CJ1W-ETN21

Ethernet Network

Take advantage of a wide range of communications capabilities. Communicate with PLCs remotely through the Internet or locally through an Ethernet network. Transfer data with TCP/IP or UDP/IP socket services, execute Omron's standard FINS commands, transfer and receive memory card files with FTP, send e-mail with SMTP or receive e-mail with POP3. Select the communications services that are required and flexibly connect PLCs on an Information-Level Ethernet network.

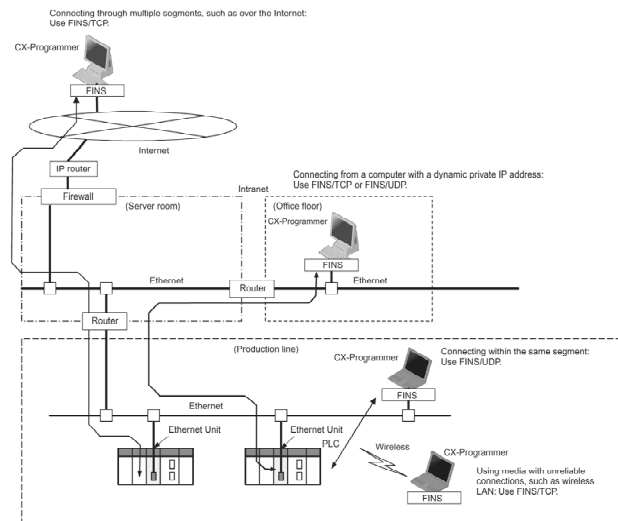

Omron's Ethernet modules support the full TCP/IP model for maximum flexibility in data exchange. Omron uses easy-to-establish routing tables to share common data table contents instead of programming requests to share specific blocks of data with specific PLCs. With Omron, all communication modules can share data within PLC memory. This allows great flexibility for future control modifications without substantial reprogramming effort.

Ethernet: Information Network

Communications Services Link Key Personnel to Important Production Information

■ Remote Programming and Monitoring

CX-Programmer running on a computer connected to the Ethernet Network can be used to program and monitor all the PLCs connected to the Ethernet Network.

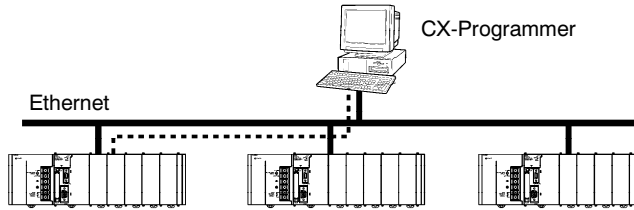

■ Socket Service

Send and receive data from devices on the same Ethernet network using UDP or TCP protocol.

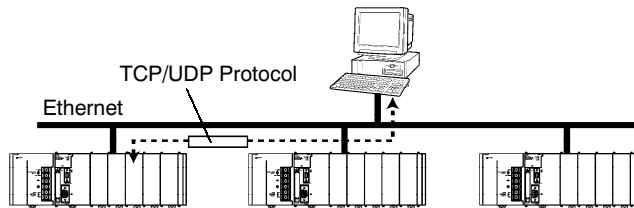

■ Mail Transmission Function

The Ethernet unit is able to send user-created data, error log data, and CPU status data as e-mail attachments using a SMTP server.

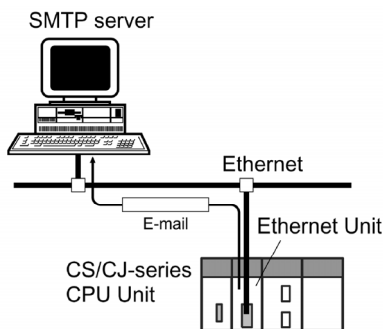

■ Mail Receive Function

Send FINS commands via e-mail through the Internet or through the local intranet. The Ethernet unit receives the commands using a POP3 server, executes the commands and sends an e-mail response to the sender.

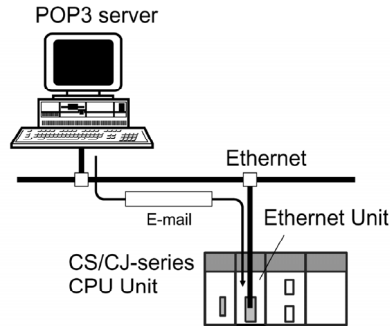

■ FINS Message Service

Send FINS messages between PLCs and host computers. FINSGateway can be used to handle messages from applications without having to program FINS commands directly.

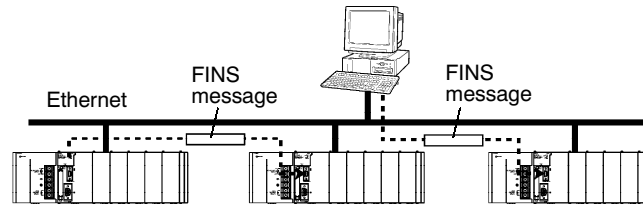

■ FTP Service

Use the FTP service to transfer and receive files between Memory Cards in the PLC CPU and computer memory.

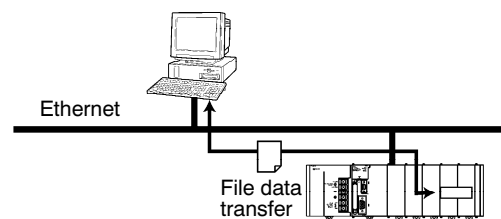

■ Automatic Clock Adjustment

The Ethernet unit can acquire clock information from an SNTP server on a triggered event, or on a regular interval. This information can be used to refresh the internal clock information of the CPU unit.

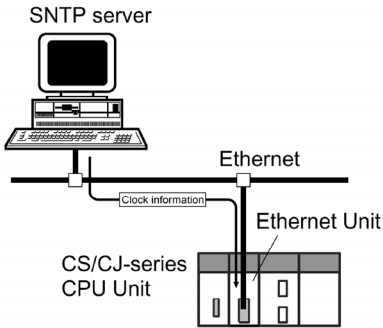

■ Specifying Servers by Host Name

POP servers, SMTP servers, and SNTP servers can be specified by Host Name rather than IP address by using the DNS client function.

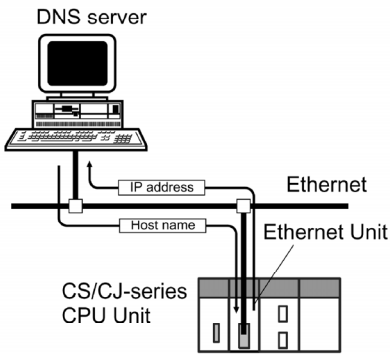

Controller Link: Peer-to-Peer Control Network

Why Use Controller Link?

Omron's Controller Link complements Ethernet by providing access to mission critical information while not disturbing the timing or execution of the main control system. It was designed specifically to handle large data transfers in applications with these requirements.

■ You'll Achieve These Goals

- Large amounts of information can be transferred from controller to controller automatically, and/or by using specific commands.
- You will utilize a supervisory system that will be constantly updated as it coordinates the output from one manufacturing cell to the next.
- Timing will be deterministic so that performance is repeatable.

These requirements can be met perfectly using Omron's Controller Link network, a network designed specifically for critical timing and large data transfers. Controller Link provides these capabilities by combining an automatic data link service with a messaging service that enables sending and receiving data when required by process conditions. The result is highly flexible data sharing that provides deterministic system response with highly effective use of data areas within the PLCs. (Refer to the Data Links illustration on this page.)

■ Features

- Controller Link supports up to 62 nodes (using Repeater Units), and each node can transmit up to 1000 words (16 bits = 1 word) of data.
- Determinism is accomplished through the use of a token passing scheme, and CRC error checking ensures that the data gets through.
- Controller Link's two media options are Shielded Twisted Pair (STP) and optical fiber.
- Like all Omron networking products, Controller Link supports transparent network routing and gateway functions while providing deterministic high-speed data transmission.

■ Controller Link Provides Two Powerful Services

The first is a *Data Link service* — large, user defined amounts of *shared memory* is instantaneously updated in all the other connected controllers.

Data Links

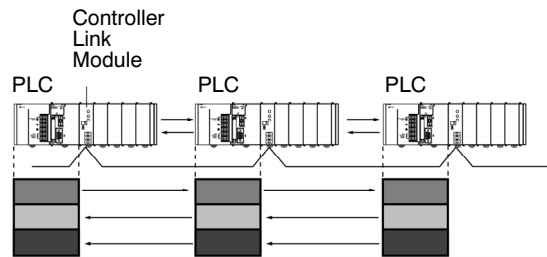

Shared memory data transfers continuously updated, I/O bits, link bits, DM Area words, etc.

The second is a *Messaging service* that can transmit data between specific nodes on specified events using simple ladder instructions.

Message Communications

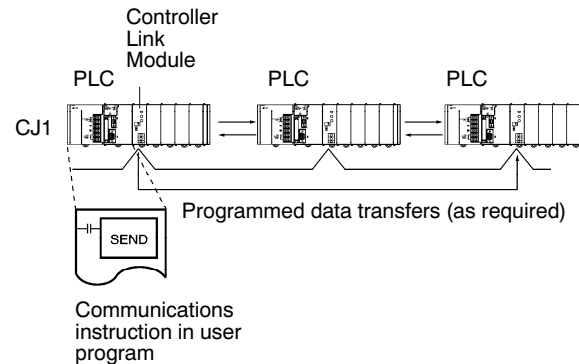

■ Features

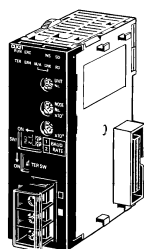

CJ1W-CLK21
Controller Link Module

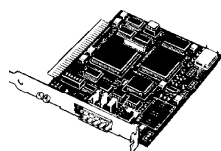

3G8F7-CLK21-EV1
Controller Link
Support Board
for PCI Bus

■ Basic Functionality

- Connect CJ1 Series, CS1 Series, S1, CV Series, CQM1H, C200HX/HG/HE PLCs and PCs simultaneously (32 nodes max.) to a maximum distance of 1 km @ 500 kbps Band Rate.
- Shielded-Twisted pair (STP) or Optical Fiber units available. (Optical Fiber connections have a high tolerance to noisy environments.)
- Complete error correction and troubleshooting functions.
- Set communications parameters using CX-Programmer software.
- Total number of data link words in one network: 32,000 words (64,000 bytes) maximum.

■ Specifications

Unit/Board	Description	Communications	Media	Specifications	Unit numbers	Model number
Controller Link Module -V1	CPU Bus Module	Data links and message communications	Shielded-Twisted-Pair Wiring	Up to 4 Modules can be mounted to CPU Rack or to Expansion Racks	0 to F (4 Modules max.)	CJ1W-CLK21-V1
Controller Support Board	PCI computer support board			IBM PC/AT or compatible (PCI)	—	3G8F7-CLK12-EV1
				IBM PC/AT or compatible (PCI)	—	3G8F7-CLK21-EV1
				IBM PC/AT or compatible (PCI)	—	3G8F7-CLK52-EV1

■ CS/CJ Version 1 (V1) Controller Link Modules:

- Connect up to 62 V1 nodes total utilizing Repeater Units.
- Transmit up to 1.5 km @ 2 Mbps Baud Rate using STP cable and STP Repeater Units.
- 1:N unequal allocation of Data Link possible using CX-Programmer v3.2 or greater.
- Data Link allocation can be changed while Data Link is running.
- Number of Data Link words per module: 12,000 words (24,000 bytes) maximum.

■ PCI Controller Link Support Board:

- Number of Data Link words in one PCI module: 32,000 words (64,000 bytes) maximum.
- Direct communication to Controller Link layer using CX-Programmer software.

Controller Link is OMRON's primary FA "Control-Level" network. It supports automatic data links between PLCs and host computer(s) on the same network. It utilizes FINS to allow programmed data transfers through multiple network layers using a message service. You get high-capacity, flexible data links and high-capacity data transfers with messages. For a low-cost communications system, shielded twisted-pair (STP) cables can be used.

Controller Link Module and Controller Link Support Board



■ CLK Relay Terminal Block

Reduce service and maintenance time by retaining system wiring using an optional CLK Relay Terminal Block. It allows replacement of a Controller Link Module while network communications are still in progress. Simply remove power to the module being replaced, make the replacement, and re-establish power.

Note: The Relay Terminal Block can be used on any node in the network *except* the end nodes.

Item	Description	Model number
CLK Relay Terminal Block	Wired Controller Link Module Relay Terminal Block	CJ1W-TB101

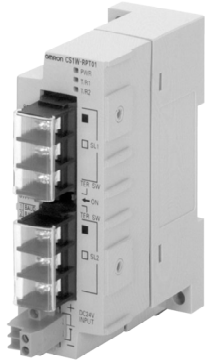
■ Repeater Units

Item	Specifications		
Model	CS1W-RPT01	CS1W-RPT02	CS1W-RPT03
External appearance			
Supported Units/Boards	All Controller Link Units/Boards for wired networks. Note: To construct a network that can contain up to 62 nodes, it is necessary to use version-1 (V1) models, which support 62 nodes.		
Transmission line	Twisted-pair cable	H-PCF cable (optical two-core cable)	GI cable (optical two-core cable; 62.5/125 μm, 50/125 μm)

Additional Information: For more details and specifications, refer to manual No. W309.

Easily Connect PLCs at the Factory Site in a Fully Functional FA Network

Easy Network Construction with Twisted-pair Cables

Multiple Drop Tree Diagrams

Utilizing repeater units with V1 CLK units, the number of network nodes has increased to 62. Based on design needs, there are multiple network layouts to work from.

T-Branch Wiring

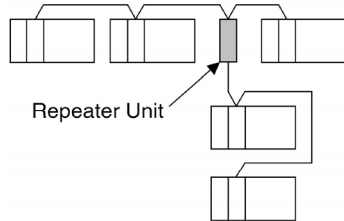

Long-distance Wiring

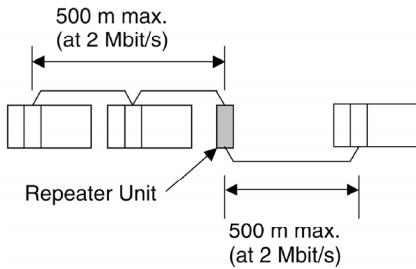

62-node Configuration

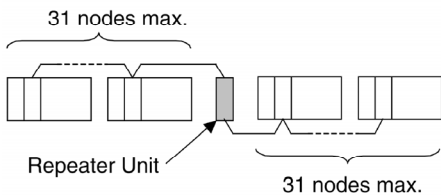

Partial Conversion to Optical

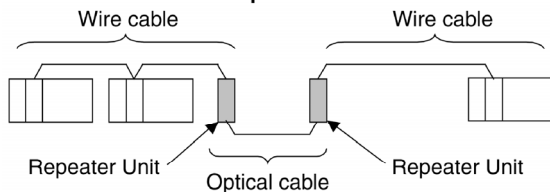

Note: Each repeater unit in the network is considered one node.

Repeater Stages/Segments

In order for all nodes to be active in the network, no more than 2 repeater units must be passed for any node to reach any other node.

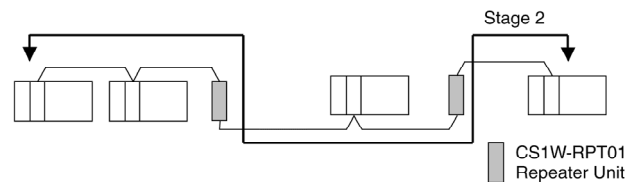
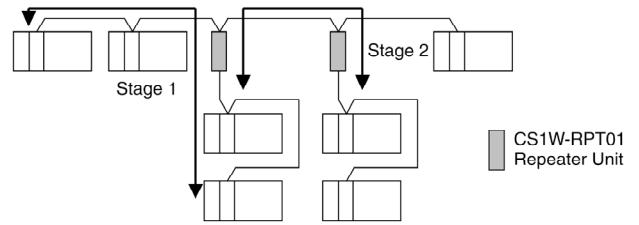

Connection of two wire-to-optical repeater units make up a single stage.

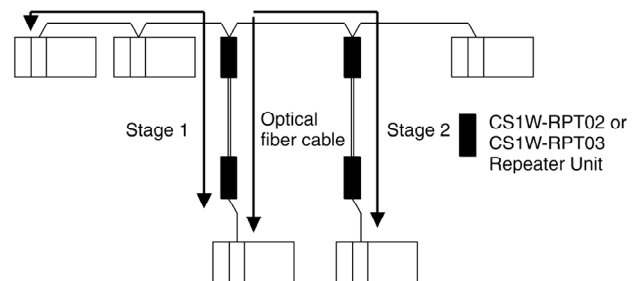

Demonstrate more than 2 stages.

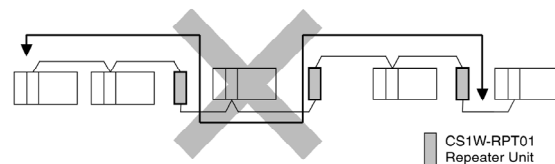
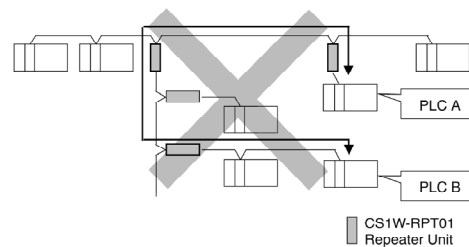

Controller Link: Control Network

Each state/segment in the network must be properly terminated.

- T-Branch
- Long-Distance
- Partial Optical

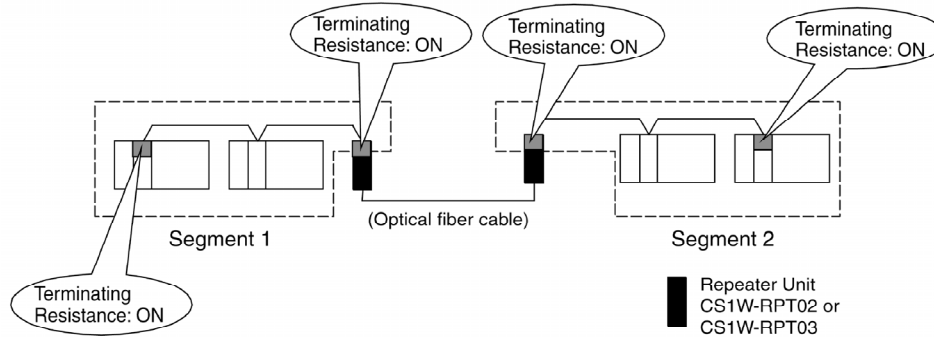
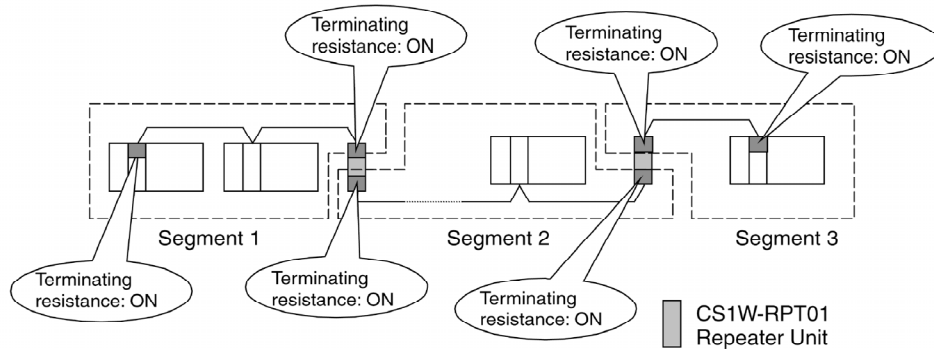
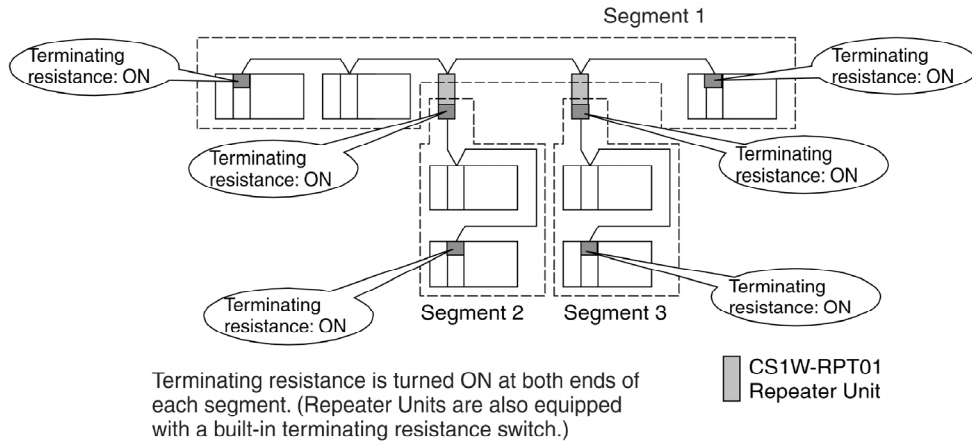

Remote Programming and Monitoring

CX-Programmer connected via RS-232C, Peripheral or Ethernet, can be used to program and monitor PLCs on the Controller Link Network.

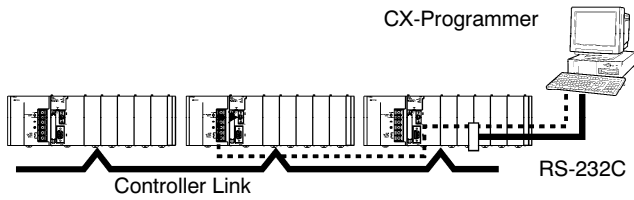

FINS Message Communications

Large volumes of data can be transferred between PLCs and host computers whenever necessary. FINSGateway software can be used to handle messages from applications without having to program FINS commands directly. FINS commands can be sent between specific Nodes while Data Link operations are ongoing.

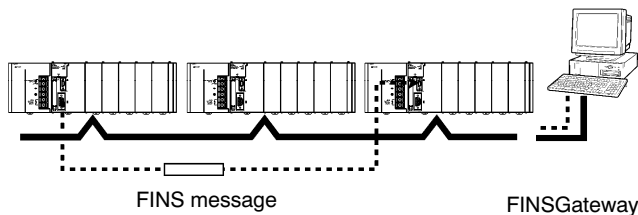

Data Links

Data links automatically exchange data in preset areas between nodes on a network. Efficient, large-capacity data links can be flexibly created between PLCs and host computers on the same network.

Automatic Data Link

Each node has a defined part of the shared memory that all other nodes can read, but not write. In this way, all information that needs to be shared is constantly updated and available to all nodes on the network.

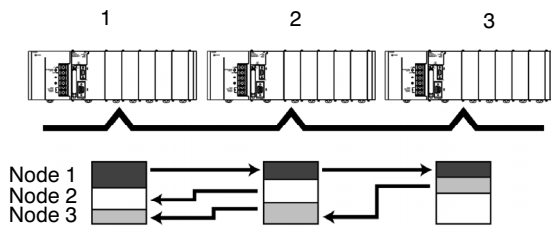

Manual Data Link

Each "node" has an area of shared memory that it writes to. If a node does not require the information from another node, it simply does not "read" that memory area.

1:N Data Link Allocation

V1 Controller Link modules support 1:N Data Link allocation. 1:N Data Link allocations allow for the master node (Node 1) to acquire data from all slave nodes (remaining network nodes) on the network in a stack format from lowest node number to the highest. This allows for only the desired data windows within a node to be transferred onto the master node data stack.

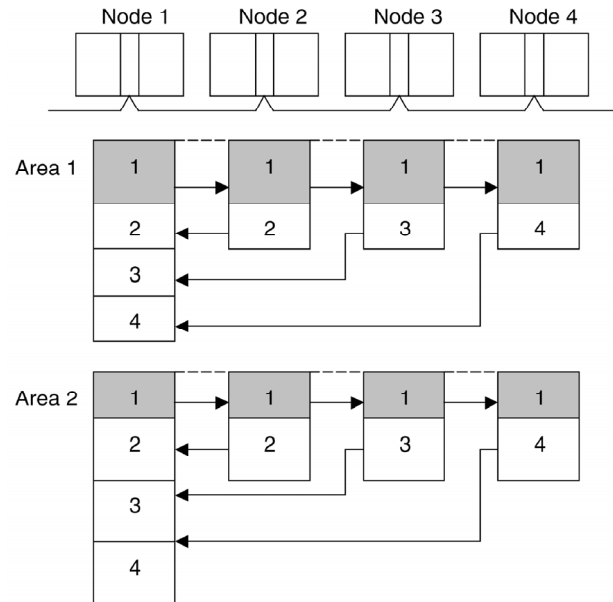

The DeviceNet Solution

Multivendor, Multibit Network

■ High-Speed Network for FA

DeviceNet is a high-speed network optimized for applications that require control of I/O on factory floor machinery.

Omron has developed an extensive offering of DeviceNet compatible products that reflect Omron's commitment to meeting two overriding operating performance principles: (1) *intuitive operation* and (2) *ease of deployment*.

To accomplish these objectives, powerful features have been built into Omron's DeviceNet Master Modules — features not seen in DeviceNet Masters from other vendors.

Omron's DeviceNet Master Modules provide the best possible DeviceNet CAN performance while simplifying network setup and configuration.

■ System Configuration

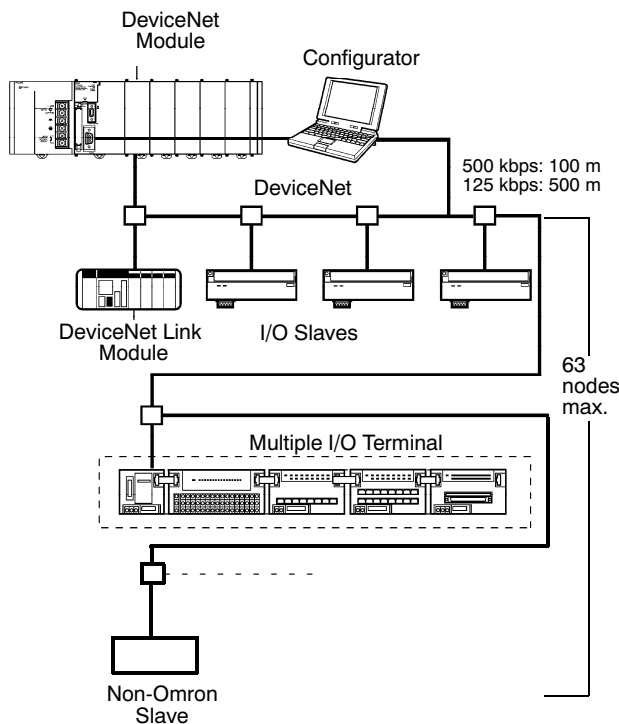

As a founding member of ODVA (Open DeviceNet Vendor's Association), Omron has implemented DeviceNet in a manner that assures ease of use and deployment. In the list that follows, you will see that our DeviceNet master units offer powerful features not found in the DeviceNet masters from other vendors.

Highlights of Omron's DeviceNet Master Modules

- **Automatic network enrollment and I/O allocation.** Configuration tools are not required to set up, map and allocate the network into controller memory.
- **I/O allocation to *any* CPU memory area *without* the use of a configuration tool.** Allocate I/O using CX-Programmer software.
- **Omron DeviceNet Master has FINS capability.** This allows DeviceNet to be used to route data or to carry programming commands to FINS-capable devices, allowing communications capabilities through Omron networked devices. FINS is a communications protocol developed by Omron and embedded in the firmware of products such as network communication master modules.
- **Large buffer memory ensuring data integrity for explicit messaging.** Omron's master has 200 words of buffer memory to ensure consistent data integrity.
- **Message handling capacity eliminates a need for any space between messages.** Omron's master provides the fastest system throughput possible by eliminating any requirement for quiet space between messages.

All of the above features provide the best possible DeviceNet performance while simplifying network setup and configuration. Omron's DeviceNet slaves are fully compatible with the latest standards to ensure open communication with legacy masters from other vendors. *Wireless DeviceNet*, an Omron exclusive combination of transmitter and receiver, opens many new networking possibilities. It removes the barriers of wires and fixed topologies, opening the door to distributed intelligence and more flexibility in the location of networked I/O.

Control up to 32,000 Points (2,000 Words) per Master

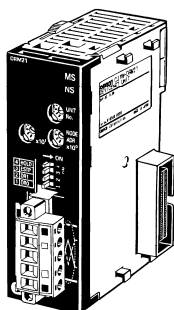

**CJ1W-DRM21
DeviceNet Module**

■ **Features**

- Control up to 32,000 points (2,000 words) per master.
- Key functionality characteristics can be set *without a Configurator*:
 - Remote I/O communications slaves can be allocated in any memory area using the DM allocation area for the DeviceNet master.
 - More than 1 DeviceNet Master Module can be mounted for each CPU (3 maximum for fixed allocations).
 - More than 1 DeviceNet Master Module can be connected in a single network (3 maximum).

- Advantages in using Omron's DeviceNet Configurator:
 - Remote I/O can be allocated in an order independent of node address.
 - Remote I/O can be allocated at the byte level allowing for I/O optimization.
 - Enables easy monitoring of the status and settings for network devices, and provides error information for the Master.
 - Up to 16 DeviceNet Master Modules can be mounted for each CPU.
- A DeviceNet Master Module can be used as both a master and slave; and, master and slave functionality can be used simultaneously.
- When using a DeviceNet Master Module, DeviceNet networks can be treated exactly like Controller Link, Ethernet, or other networks for message communications or remote programming and monitoring by CX-Programmer software.
- The CJ1W-DRM21 Master Module supports Poll, Bit-Stroke, COS, and cyclic communications.
- Using the CJ1W-DRM21, setup files can be transferred from or downloaded to CF, allowing for swift onsite response.

■ **Specifications**

Product	Types of communications	Specifications	Unit numbers	Model number
CPU Bus Module	Remote I/O Communications Master (fixed or user-set allocations) Remote I/O communications slave (fixed or user-set allocations) Message communications	Up to 16 Modules can be mounted when a Configurator is used. (3 maximum without configurator)	0 to F (Configurator required to mount 16 Modules.)	CJ1W-DRM21

■ **DeviceNet Configurator**

Product	Specifications	Model number
DeviceNet Configurator	Software only (Windows 95, 98, NT 4.0, or 2000, XP)	WS02-CFDC1-E
	PCMCIA card with software (Windows 95, 98, ME, 2000, XP)	3G8E2-DRM21-EV1

■ **Setting/Monitoring Software**

Product	Specifications	Model number
NX-Server	DDE edition — serve network info to spreadsheets	WS02-NXD1-E

Additional Information: For more details and specifications, refer to manual No. W380.

DeviceNet Slave Modules

■ DeviceNet: Component Network

Create a multi-vendor network for multibit communications for lower-level PLCs that need to handle both control signals and data.

■ Remote I/O Communications

Large-capacity remote I/O can be freely allocated according to application needs.

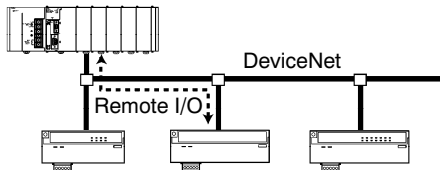

■ Message Communications

Send FINS messages between OMRON PLCs and Explicit messages between OMRON PLCs and devices from other makers.

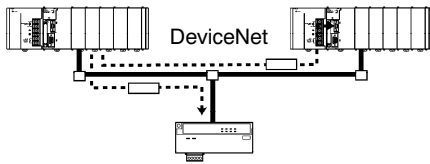

■ Select from a Wide Range of Slaves

Connect discrete I/O, analog I/O, temperature inputs, enhanced specialty nodes, and small PLCs. Most DeviceNet Slaves count as one node on the network, except for Multiple I/O Terminal Units.

■ Use Multiple I/O Terminal Units as DeviceNet Slaves

I/O can be expanded through one-step connections. Special I/O and explicit messages are also supported. Multiple I/O DeviceNet Slaves allow connection of up to 256 I/O points per node; analog input points allow a maximum of 1,024 points.

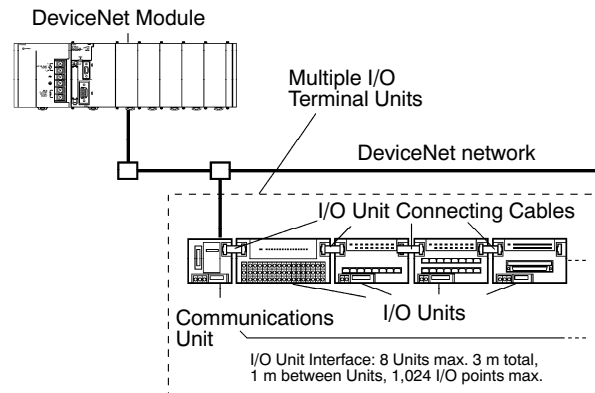

■ DeviceNet Slaves

Product		Specifications	Model number
Programmable Slaves		Controller with CPM2C CPU No. of remote I/O link points: 1,024 max. Provides CompoBus/S Master.	4 transistor outputs (sinking)
			4 transistor outputs (sourcing)
I/O Link Modules		512 internal inputs/512 internal outputs (between CS1 Series or C200HX/HG/HE PLC and Master)	C200HW-DRT21
		16 internal inputs/16 internal outputs (between CQM1/CQM1H and Master)	CQM1-DRT21
		32 internal inputs/32 internal outputs (between CPM1A/CPM2A and Master)	CPM1A-DRT21
Smart DeviceNet I/O Terminals	Basic Units	16 input points, NPN	DRT2-ID16
		16 input points, PNP	DRT2-ID16-1
		16 output points, NPN	DRT2-OD16
		16 output points, PNP	DRT2-OD16-1
	Expansion Units	8 input points, NPN	XWT-ID08
		8 input points, PNP	XWT-ID08-1
		8 output points, NPN	XWT-OD08
		8 output points, PNP	XWT-OD08-1
		16 input points, NPN	XWT-ID16
		16 input points, PNP	XWT-ID16-1
		16 output points, NPN	XWT-OD16
16 output points, PNP	XWT-OD16-1		

(This table continues on the next page.)

DeviceNet Slaves (continued)

Product		Specifications	Model number		
Smart DeviceNet I/O Terminals	Analog I/O Terminal	4 inputs (0 to 5 V, 1 to 5 V, 0 to 10 V, ± 10 V, 0 to 20 mA, 4 to 20 mA)	Resolution: 12 bit; 1/6,000; 4 ms max./4 pt conversion time	DRT2-AD04	
		2 outputs (0 to 5 V, 1 to 5 V, 0 to 10 V, ± 10 V, 0 to 20 mA, 4 to 20 mA)	Resolution: 12 bit; 6,000; 2 ms/pt conversion time	DRT2-DA02	
	IP67 Rated Transistor I/O Terminals with M12 Connectors	16 input points, NPN		DRT2-HD16C	
		16 input points, PNP		DRT2-HD16C-1	
		8 input points, NPN		DRT2-ID08C	
		8 input points, PNP		DRT2-ID08C-1	
		8 output points, NPN		DRT2-OD08C	
		8 output points, PNP		DRT2-OD08C-1	
Remote I/O Terminals with Transistors	8 input points, NPN		DRT1-ID08		
	8 input points, PNP		DRT1-ID08-1		
	8 output points, NPN		DRT1-OD08		
	8 output points, PNP		DRT1-OD08-1		
	16 input points, NPN		DRT1-ID16		
	16 input points, PNP		DRT1-ID16-1		
	16 output points, NPN		DRT1-OD16		
	16 output points, PNP		DRT1-OD16-1		
Remote I/O Terminals with Transistors and 3-Tier Terminal Block	Common power supply for communications and internal circuits	16 input points, NPN		DRT1-ID16TA	
		16 input points, PNP		DRT1-ID16TA-1	
		8 input points, NPN 8 output points, NPN		DRT1-MD16TA	
		8 input points, PNP 8 output points, PNP		DRT1-MD16TA-1	
		16 output points, NPN		DRT1-OD16TA	
		16 output points, PNP		DRT1-OD16TA-1	
	Separate power supplies for communications and internal circuits	16 input points, NPN		DRT1-ID16T	
		16 input points, PNP		DRT1-ID16T-1	
		8 input point, NPN 8 output points, NPN		DRT1-MD16T	
		8 input point, PNP 8 output points, PNP		DRT1-MD16T-1	
		16 output points, PNP		DRT1-OD16T	
		16 output points, NPN		DRT1-OD16T-1	
		Remote I/O Terminals with transistors and connectors	32 input points, NPN		DRT1-ID32ML
			32 input points, PNP		DRT1-ID32ML-1
32 output points, NPN			DRT1-OD32ML		
32 output points, PNP			DRT1-OD32ML-1		
16 input points, NPN 16 output points, NPN			DRT1-MD32ML		
16 input points, PNP 16 output points, PNP			DRT1-MD32ML-1		
Mounting Bracket B	—		SRT2-ATT02		

(This table continues on the next page.)

DeviceNet Slave Modules

DeviceNet Slaves (continued)

Product	Specifications	Model number	
Remote Adapters	16 input points, NPN, prewired connector	DRT1-ID16X	
	16 input points, PNP, prewired connector	DRT1-ID16X-1	
	16 output points, NPN, prewired connector	DRT1-OD16X	
	16 output points, PNP, prewired connector	DRT1-OD16X-1	
	Flat Ribbon Cable Connectors with MIL plugs	Straight DIP pins	XG4A-2031
		L-shaped DIP pins	XG4A-2034
DeviceNet Sensor Communication Module for E3X-DA Fiber Amplifier (refer to the expanded info on E3X-DA at the end of this section)	Connects to up to 16 Fiber Amplifier Units for the E3X-DA-N	E3X-DRT21	
	Fiber Amplifier Unit	E3X-DA6-P	
	Reduced-wiring Connector	E3X-CN02	
	Terminal Unit, connects one sensor or switch	E39-TM1	
Sensor Terminals (for 2-wire Sensors)	8 sensor I/O points, NPN, 2 inputs per Sensor	DRT1-HD16S	
	8 sensor I/O points, PNP	DRT1-ND16S	
	Cable Connectors	0.3 to 0.5 mm ²	XS8A-0441
		0.14 to 0.2 mm ²	XS8A-0442
Water-Resistant Terminals (IP67)	4 input points, NPN	DRT1-ID04CL	
	4 input points, PNP	DRT1-ID04CL-1	
	4 output points, NPN	DRT1-OD04CL	
	4 output points, PNP	DRT1-OD04CL-1	
	8 input points, NPN	DRT1-ID08CL	
	8 input points, PNP	DRT1-ID08CL-1	
	8 output points, NPN	DRT1-OD08CL	
	8 output points, PNP	DRT1-OD08CL-1	
Environment-Resistant Terminals (IP65)	8 input points, NPN	DRT1-ID08C	
	16 input points, NPN	DRT1-HD16C	
	16 input points, PNP	DRT1-HD16C-1	
	8 output points, NPN	DRT1-OD08C	
	16 output points, NPN	DRT1-WD16C	
	16 output points, PNP	DRT1-WD16C-1	
	8 input points, NPN 8 output points, NPN	DRT1-MD16C	
	8 input points, PNP 8 output points, PNP	DRT1-MD16C-1	
B7AC Interface Terminal	10 input points x 3 (3 branches for the B7AC)	DRT1-B7AC	
Analog Input Terminals	4 input points (4 words) or 2 input points (2 words) (Set via DIP switch.)	DRT1-AD04	
	4 input points (4 words)	DRT1-AD04H	
Analog Output Terminals	2 output points (2 words)	Current: 0 to 20 mA, 4 to 20 mA	DRT1-DA02
		Voltage: 1 to 5 V, 0 to 10 V, - 10 to 10 V	
Temperature Input Terminals	4 input points (4 words)	Thermocouple type inputs: R, S, K1, K2, J1, J2, T, E, B, N, L1, L2, U, W, PLII	DRT1-TS04T
		RTD type inputs: Pt100, JPt100	DRT1-TS04P
RS-232C Unit	Two RS-232C ports, 16 inputs (signal status)	DRT1-232C2	
Digital Temperature Controller	DeviceNet-compatible 1-loop Controller	E5EK-AA2-DRT	
High-Density Temperature Controller	DeviceNet-compatible 8-loop Temperature Controller	E5ZE-8□D1-□B-V2	
Multi-function Compact Inverter DeviceNet Communications Unit	DeviceNet Communications Unit for the 3G3MV AC Inverters	3G3MV-PDRT1-SINV	

(This table continues on the next page.)

DeviceNet Slaves (continued)

Product	Specifications	Model number
High-Function General-purpose Inverter DeviceNet Communications Module	DeviceNet Communications Unit for the 3G3RV and 3G3FV AC Inverters	3G3FV-PDRT1-SIN
Intelligent Flag III	DeviceNet-compatible RFID system	V600-HAM42-DRT
Vision Sensor Controller	DeviceNet-compatible F150-3 Vision System	F150-C10V3-DRT
Super-compact Signal Converter Bases	DeviceNet-compatible Bases	K3FM-BI□/BO□
Operator Interface Terminal DeviceNet Interface Unit	DeviceNet Interface Unit for the NT31/NT631 Series	NT-DRT21
DeviceNet Wireless Modules	DeviceNet Wireless Master Module 1600 input/1600 output bits	WD30-ME
	DeviceNet Wireless Slave Module 512 input/512 output bits	WD30-SE

Multiple I/O Terminal Units

Multibit Building-Block DeviceNet Slave

System Configuration

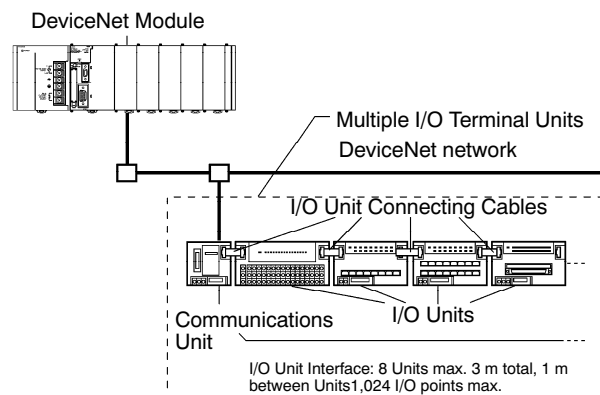

Advantages

A Communications Unit can be connected to DeviceNet to interface various types of I/O Units. Allocations and address settings are not required for the I/O Units, enabling flexible, simple distributed I/O.

Features

- To expand I/O, merely add I/O Units to the I/O interface.
- Create a low-cost multibit system.
- Connect up to 8 Multiple I/O Terminals to one Communications Unit.
- Mix Digital and Analog Units.
- Select from a wide range of I/O Units.

Product		I/O points	Specifications	Model number
Communications Unit		—	Communication Gateway to up to 8 GT1's; 1024 I/O max.	DRT1-COM
Digital I/O Units	Units with Terminal Blocks	16 inputs	NPN	GT1-ID16
		16 inputs	PNP	GT1-ID16-1
		16 outputs	NPN	GT1-OD16
		16 outputs	PNP	GT1-OD16-1
	Units with MOLEX Connectors	16 inputs	NPN	GT1-ID16MX
		16 inputs	PNP	GT1-ID16MX-1
		16 outputs	NPN	GT1-OD16MX
		16 outputs	PNP	GT1-OD16MX-1
	Units with Fujitsu Connectors	16 inputs	NPN	GT1-ID16ML
		16 inputs	PNP	GT1-ID16ML-1
		16 outputs	NPN	GT1-OD16ML
		16 outputs	PNP	GT1-OD16ML-1
	Units with D-Sub 25-pin Connectors	16 inputs	NPN	GT1-ID16DS
		16 inputs	PNP	GT1-ID16DS-1
		16 outputs	NPN	GT1-OD16DS
		16 outputs	PNP	GT1-OD16DS-1
Units with High-density Fujitsu Connectors	32 inputs	NPN	GT1-ID32ML	
	32 inputs	PNP	GT1-ID32ML-1	
	32 outputs	NPN	GT1-OD32ML	
	32 outputs	PNP	GT1-OD32ML-1	
Analog Input Units		8 inputs	MOLEX connector, 16 bits per point	GT1-AD08MX
		4 inputs	Terminal block, 16 bits per point	GT1-AD04
Analog Output Units		4 outputs	MOLEX connector	GT1-DA04MX
		4 outputs	Terminal block	GT1-DA04
Temperature Input Units		4 inputs	Thermocouple	GT1-TS04T
		4 inputs	Platinum resistance thermometer	GT1-TS04P
Counter Unit		1 input, 2 outputs	1 input, 2 outputs Counter Unit with encoder input	GT1-CT01
Relay Output Units		8 outputs	8 relay outputs, 2 A, SPST-NO	GT1-ROP08
		16 outputs	16 relay outputs, 5 A, SPST-NO	GT1-ROS16
I/O Unit Connecting Cable		—	1 m	GCN1-100

Note: For connection information for units with "MX" in the part number, please see page 153 in the *Ordering Information* section.



CJ1W-PRM21
DeviceNet Module



Profibus-DP (PROcess Field BUS – Decentralized Periphery) is a vendor-independent, open fieldbus standard for a wide range of applications in manufacturing, process and building automation. Vendor independence and transparency of operation are guaranteed by the Profibus standard EN50170. With Profibus, devices of different manufacturers can communicate without special interface adjustments.

■ **Features**

- CPU bus module where up to 16 masters can be mounted per PLC.
- Supports cyclic communications with up to 125 slave stations per network.
- Total size of I/O data for all Profibus masters mounted per PLC must not exceed 7,168 words.
- Utilizes FDT/DTM Technology:
 - FDT (Field Device Tool): An FDT container application (ie. CX-Profibus) allows for configuration, manipulation and monitoring of network nodes.
 - DTM (Device Type Managers): A Microsoft COM-component provided by the device manager that allows for interactive configuration and diagnostics, similar to a printer driver.
- Profibus allows for multiple masters per network and utilizes a token passing procedure which allows the token possessing master to poll its assigned slaves.
- Profibus Configurator enables easy monitoring of the status and settings for network devices, and provides error information for the master.

■ **Diagnostic Messages**

- Device Related Diagnostics: Messages to determine the operational status of the whole device (ie. over temperature, low voltage)
- Module Related Diagnostics: Messages to identify an error in a specific range of I/O for a slave station (ie. an 8-bit output module)
- Channel Related Diagnostics: Messages indicating an error at a given input or output (ie. short circuit on output 5)

Note: Profibus master modules support the storage of up to 80 error events.

■ **Troubleshooting**

- Extensive self-diagnostic function at startup
- Dedicated status flags, indicating if I/O data is being exchanged within the assigned slave stations
- Dedicated status flags, indicating if new slave diagnostic data is available
- Extensive status and error flags, indicating the status of the module and the Profibus network
- Error log for recording error history data

Item	Description			
Applicable Standard	EN 50170 Part 2 (Profibus-DP)			
Network Media/Topology	RS-485 Bus, 125 slave node stations max.			
Connector	Female D-Sub 9-pin			
Cable Length/Transmission Rate	Baud Rate (kbit/s)	Distance/segment (m)	Baud Rate (kbit/s)	Distance/segment (m)
	9.6	1200	500	400
	19.2	1200	1500	200
	45.45	1200	3000	100
	93.75	1200	6000	100
	187.5	1000	12000	100
I/O Available per PLC	7,168 words max. (for all Profibus masters connected to one PLC)			
Error Reporting	Max. of 80 error events can be logged			
Supported FINS Messages	MEMORY AREA READ ERROR LOG READ ERROR LOG CLEAR RUN STOP			
Supported Services	Set_PRM Chk_Cfg Slave_Diag Data_Exchange Global_Control (FREEZE, UNFREEZE, SYNC, UNSYNC, CLEAR)			

ProfiBus-DP

■ Network Components

ProfiBus-DP Slave Unit for CJ1

Model	CJ1W-PRT21	
Maximum Number of Units per PLC	40	
Data Area Size	Up to 100 words input in one PLC area (CIO, H, D, E) Up to 100 words output in one PLC area (CIO, H, D, E) Inputs and outputs must not exceed 180 words	
Supported Services (as Responder)	To DPM1 and DPM2 masters	Data_Exchange Slave_Diag Set_PRM Chk_Cfg Global_Control (SYNC/FREEZE/CLEAR)
	To DPM2 master only	Rd_Inp Rd_Outp Get_Cfg
Bus and Unit Status Display (GSD File)	LED Available with module	

C200HW ProfiBus-DP Master for C200H and CS1 PLCs

Model	C200HW-PRM21
Max. Data Size	2 input and 2 output areas
Data Area Size	300 words
Number of Masters per PLC without Configurator	1
Number of Masters per PLC with Configurator	10 on C200H \times PLC (16 on CS1 PLC)
Power Consumption	600 mA, 5V DC

ProfiBus-DP I/O Link Unit for C200H and CS1

Model	C200HW-PRT21
Number of I/O (selectable)	8 + 8 . . . 1600 + 1600
Number of Reserved I/O Words	1 + 1 . . . 100 + 100
C200HE/HG/HX and CS1G/H CPUs	All
Power Consumption	250 mA, 5V DC
Bus and Unit Status Display	LED
Accessories	GSD file on disk

Multiple I/O ProfiBus-DP Interface Module - DIN Rail Mounting

Model	PRT1-COM
Communications Port	ProfiBus-DP to EN50170, Part 2
Number of Multiple I/O Modules	Max. 8
Number of I/Os	512 inputs and 512 outputs
Length of I/O Connecting Cable	Max. 3m

Programming

Item	Description	Model
Profibus Configurator	Network Configuration Software (Windows NT 4.0, 2000, XP)	CX-Profibus

Technical Documentation - English

Product	Title	Model
CS1/CJ1 Profibus-DP Master Unit	Operation Manual	W409
Profibus-DP Master Unit		W349
C200HW-PRT21 Profibus-DP Slave Unit		W901
Profibus-DP Multiple I/O Terminal		W900
CJ1W-PRT21 Profibus-DP Slave Unit		W408

A New Standard for Distributed Control and Reduced Wiring

Advantages

CompoBus/S provides local I/O update speeds combined with the ability to distribute the I/O over as much as 500 meters! It's like installing a 256-point I/O Module in a single slot on a Programmable Controller. The actual I/O Terminals are connected with a single twisted-pair cable in a daisy chain connection scheme. With a wide variety of wiring connection options for remote I/O Terminals and analog capability, CompoBus/S can expand system-mounting options while providing reduced wiring and start-up cost benefits. Update times can be as fast as 0.8 ms for 256 field mounted I/O. This cost-effective remote I/O solution has created a whole new standard for speed and value in distributed I/O.

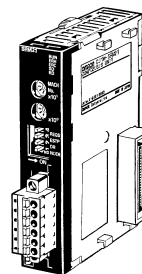

CJ1W-SRM21

CompoBus/S Distributed I/O Network

CompoBus/S is a high-speed bus that automatically transfers remote I/O status to the CPU without any programming in the CPU.

System Configuration

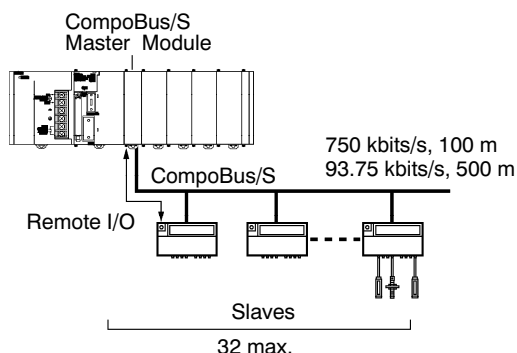

Features

- Up to 256 I/O points per Master
- Up to 32 Slaves per Master
- Communications cycle time: 0.8 ms (fastest speed) (at 750 kbps) over 100 m
- Communications distance: Up to 500 m (at 93.75 kbps) over 100 m
- Analog I/O Terminals available
- Free wiring with any branching method for up to 200 m (in long-distance communications mode)

CompoBus/S Master Module Specifications

Product	Description	Model number
CompoBus/S Master Module	I/O points	256 (128 inputs and 128 outputs) or 128 (64 inputs and 64 outputs) switch-selectable
	Allocated words	For 256 I/O: 20 words (8 for inputs, 8 for outputs, 4 for status) For 128 I/O: 10 words (4 for inputs, 4 for outputs, 2 for status)
	No. of mountable Master Modules	40 (limit of 20 for CJ1M)
	Node address	8 addresses per node
	No. of connectable Slaves	32
	Status information	Communications Error Flags, Participation Flags
	Unit numbers	0 to 94 (when 2 unit numbers are allocated to each Master) 0 to 95 (when 1 unit number is allocated to each Master)

Note: Uses Special I/O Module Area (in CIO Area).

Additional Information: For more details and specifications on any of these modules, refer to manual No. W266.

CompoBus/S Modules

■ Communications Specifications

Communications method		Special CompoBus/S protocol			
Coding		Manchester			
Connections		Multidrop, T-branch (requires termination)			
Baud rate		High-speed mode: 750 kbps Long-distance mode: 93.75 kbps. Set via DIP switch. (Set via DM Area; Default: 750 kbps.)			
Communications cycle time	High-speed mode	0.5 ms (with 8 input and 8 output Slaves)			
		0.8 ms (with 16 input and 16 output Slaves)			
	Long-distance mode	4.0 ms (with 8 input and 8 output Slaves)			
		6.0 ms (with 16 input and 16 output Slaves)			
Media		2-conductor cable (VCTF 0.75 x 2), 4-conductor cable (VCTF 0.75 x 4), or Special Flat Cable			
Maximum communications distance		With 2-conductor VCTF Cable			
		Mode	Main	Branch	Total branch
		High-speed	100 m	3 m	50 m
		Long-distance	500 m	6 m	120 m
		With 2-conductor VCTF or Special Flat Cable			
		Mode	Main	Branch	Total branch
High-speed (See note 1.)	30 m	3 m	30 m		
Long-distance (See note 2.)	Any up to 200 m total				
Max. No. of nodes		32			
Error control checks		Manchester code, frame length, and parity checks			

Note: 1. For 16 slaves or fewer: main: 100 m; total branch: 50 m.

2. No restrictions on branching method or individual line lengths. Connect terminating resistance to Slave farthest from Master.

■ CompoBus/S Slaves

Product	Specifications	Model number	
I/O Link Modules	For CPM2C; 8 input points, 8 output points	CPM2C-SRT21	
	For CPM1A/CPM2A; 8 input points, 8 output points	CPM1A-SRT21	
Remote I/O Terminals with Transistors	4 input points, NPN	SRT2-ID04	
	4 input points, PNP	SRT2-ID04-1	
	4 output points, NPN	SRT2-OD04	
	4 output points, PNP	SRT2-OD04-1	
	8 input points, NPN	SRT2-ID08	
	8 input points, PNP	SRT2-ID08-1	
	8 output points, NPN	SRT2-OD08	
	8 output points, PNP	SRT2-OD08-1	
	16 input points, NPN	SRT2-ID16	
	16 input points, PNP	SRT2-ID16-1	
	16 output points, NPN	SRT2-OD16	
	16 output points, PNP	SRT2-OD16-1	
	Remote I/O Terminals with Transistors and 3-tier Terminal Block	16 input points, NPN	SRT2-ID16T
		16 input points, PNP	SRT2-ID16T-1
16 I/O points, NPN		SRT2-MD16T	
16 I/O points, PNP		SRT2-MD16T-1	
16 output points, NPN		SRT2-OD16T	
16 output points, PNP		SRT2-OD16T-1	
Remote Input Terminals with Transistors and Connectors	4 input points, NPN	SRT2-ID04MX	
	8 input points, PNP	SRT2-ID08MX	
Remote Output Terminals with Relays	8 relay output points	SRT2-ROC08	
	16 relay output points	SRT2-ROC16	
	8 power MOSFET relay output points	SRT2-ROF08	
	16 power MOSFET relay output points	SRT2-ROF16	
Remote I/O Terminals with Transistors and Connectors	32 input points, NPN	SRT2-ID32ML	
	32 input points, PNP	SRT2-ID32ML-1	
	32 output points, NPN	SRT2-OD32ML	
	32 output points, PNP	SRT2-OD32ML-1	
	32 I/O points, NPN	SRT2-MD32ML	
	32 I/O points, PNP	SRT2-MD32ML-1	
	8 input points, NPN	SRT2-VID08S	
	8 input points, PNP	SRT2-VID08S-1	
	8 output points, NPN	SRT2-VOD08S	
	8 output points, PNP	SRT2-VOD08S-1	
	16 input points, NPN	SRT2-VID16ML	
	16 input points, PNP	SRT2-VID16ML-1	
	16 output points, NPN	SRT2-VOD16ML	
	16 output points, PNP	SRT2-VOD16ML-1	
	Mounting Bracket A	SRT2-ATT01	
	Mounting Bracket B	SRT2-ATT02	

(This table continues on the next page.)

CompoBus/S Modules

CompoBus/S Slaves (continued)

Product	Specifications	Model number
Waterproof Terminals (with Transistors)	4 input points, NPN	SRT2-ID04CL
	4 input points, PNP	SRT2-ID04CL-1
	4 output points, NPN	SRT2-OD04CL
	4 output points, PNP	SRT2-OD04CL-1
	8 input points, NPN	SRT2-ID08CL
	8 input points, PNP	SRT2-ID08CL-1
	8 output points, NPN	SRT2-OD08CL
	8 output points, PNP	SRT2-OD08CL-1
CompoBus/S Fiber Amplifier Sensor Communication Module	Connects to up to 14 E3X-DA Fiber Amplifier Units communications	E3X-SRT21
Sensor Terminals	8 Sensor inputs, NPN	SRT2-ID08S
	4 Remote-teaching sensor inputs, 4 outputs (NPN)	SRT2-ND08S
	8 Sensor outputs, NPN	SRT2-OD08S
Analog Input Terminal	1 to 4 inputs (set via DIP switch)	SRT2-AD04
Analog Output Terminal	1 or 2 outputs (set via DIP switch)	SRT2-DA02
Remote I/O Modules	16 input points, NPN	SRT2-ID16P
	16 output points, NPN	SRT2-OD16P

Supports Simple-to-Use Links with all Serial Devices, Operator Interface Terminals, and Host Computer

Serial Communications Modules

A Serial Communications Module can be used to increase the number of serial ports (RS-232C or RS-422A/485) two at a time. Specify Protocol Macros, Host Link Communications, or 1:N NT Links separately for each port. With the CJ1 Series, you can easily provide the right number of serial ports for your system.

Features

- Mount up to 16 Modules (including all other Communications Bus Modules) on CPU or Expansion Racks.
- Up to 32 additional serial port connections with protocol setting for each port.

Serial Communications Modules
CJ1W-SCU21
CJ1W-SCU41

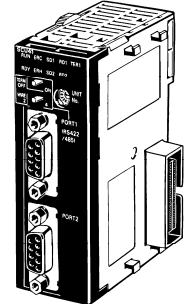

System Configuration

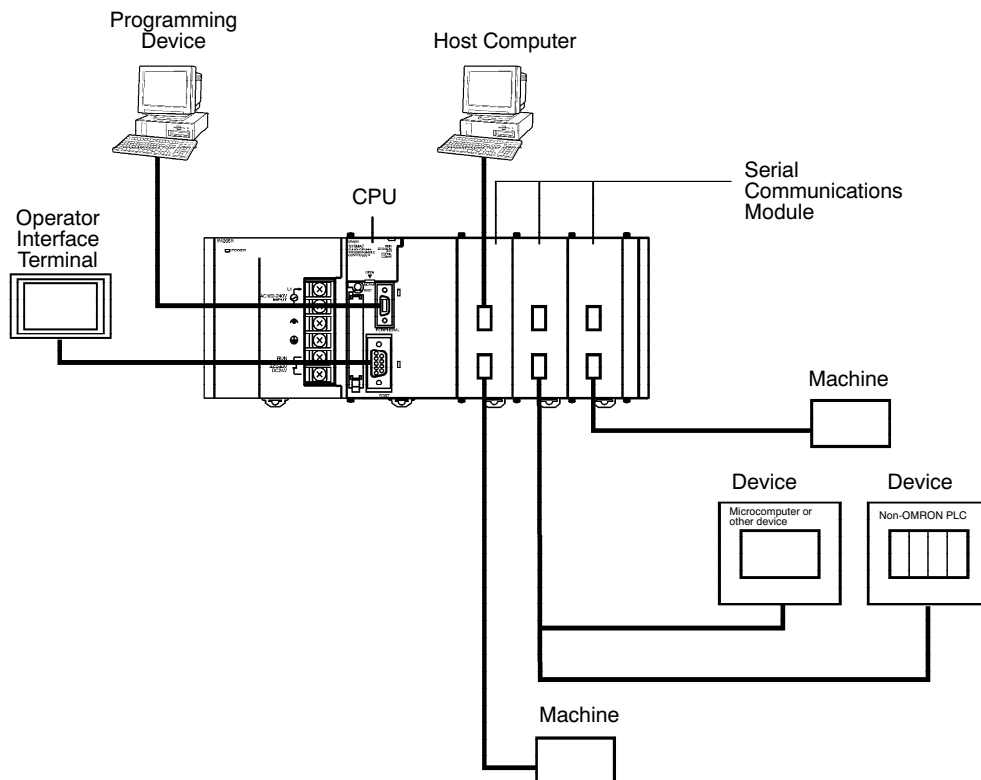

Specifications

Product	Classification	Serial communications modes	Serial ports	Unit numbers	Model number
Serial Communications Module	Communications Bus Module	Set separately for each port: Protocol Macro, Host Link, or 1:N NT Link	RS-232C x 2	0 to F	CJ1W-SCU21
			RS-232C x 1 RS-422A/485 x 1		CJ1W-SCU41

Additional Information: For more details and specifications, refer to manual No. W336.

Serial Communications Modules

■ Serial Communications Modules Capabilities

Unit or Module	Model	Ports	Serial communications mode						BASIC programming	Message communications
			Protocol macros	Host Link	NT Links	No-protocol	Peripheral bus	Programming Console bus		
			General-purpose external devices	Host computers	OMRON Operator Interface Terminals	General-purpose external devices	Programming Devices	Programming Console		
CPUs	All models	Port 1: Peripheral	No	Yes	Yes	No	Yes	Yes	No	No
		Port 2: RS-232C				Yes		No		
Serial Communications Modules	CJ1W-SCU21	Port 1: RS-232C	Yes	Yes	Yes	No	No	No	No	No
		Port 2: RS-232C								
Serial Communications Modules	CJ1W-SCU41	Port 1: RS-422/RS-485	Yes	Yes	Yes	No	No	No	No	No
		Port 2: RS-232C								
DeviceNet RS-232C Unit	DRT1-232C2	Port 1: RS-232C	No	No	No	No	No	No	No	Yes
		Port 2: RS-232C								

All the Capacity and Advanced Capabilities Needed for HMI, Communications or Data Processing

Other Protocols

OMRON provides all of the capabilities and capacity you need for the advanced programming required for Human-Machine Interfaces (HMI), communications, data processing, and other required applications.

Host Links

Host Link (C-mode) commands or FINS commands placed within host link headers and terminators can be sent to a host computer to read/write I/O memory, read/control the operating mode, and perform other operations for the PLC.

Unsolicited messages can also be sent from the PLC to the host computer by sending FINS commands from the ladder program using the SEND(090), RECV(098), and CMND(490) instructions.

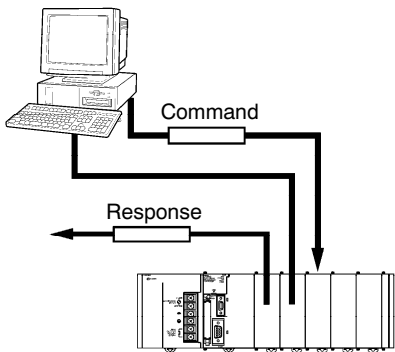

1:N NT Links

The PLC can be connected to an Omron Operator Interface Terminal via RS-232C or RS422A/485 ports; I/O memory in the PLC can be allocated to various Operator Interface Terminal functions, including status control areas, status notifications areas, touch switches, lamps, memory tables, and other objects.

Addition of High-Speed NT Links

High-speed NT Links (three times faster than conventional host link transmissions) are possible with the NS Series and version 2 of the NT631 and NT31 Series. This speed is particularly important when connecting to more than one Operator Interface Terminal.

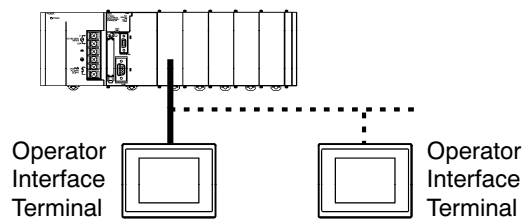

Note: Up to eight Operator Interface Terminals can be connected to a PLC using 1:N NT Links.

Serial Communications Protocols

Serial Communications instructions (TXD and RXD) for communications ports can be used for simple data transfers, such as to input data from bar code readers or output data to a printer. Start/end codes can be specified, and RS, CS, and other control signals can be handled. (Serial Communications instructions can only be used with the built-in RS-232C port.)

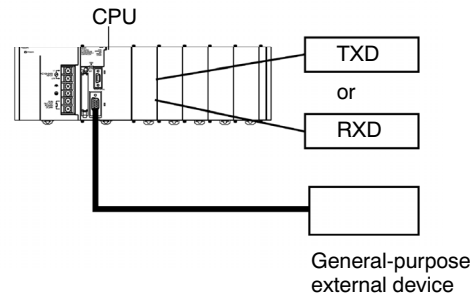

Protocol Macros

Easily Create Protocols for Data Exchange with External Devices and Execute with One Instruction

■ Features

- Communicates with almost any external device with an RS-232C or RS-422/485 port.
- Standard protocols included for Omron temperature controllers, panel meters, bar code readers and encoders.
- Use CX-Protocol Windows-based software to create protocols for any non-Omron device.

Omron's CJ1 offers serial communications in addition to what is standard on the CPU with additional Communication Bus Modules. These modules are necessary to expand on the CPU's Serial Port functionality. By incorporating a separate communication bus, all data exchanges and setting changes do not affect the cycle time of the control functions.

An exclusive time-saving setup feature built into Omron controllers, called Protocol Macro, contains the hand-shaking commands for many of Omron's controllers with serial communications. A Protocol Macro instruction in the PLC, called from the ladder diagram, designates the serial device and serial communications starts up automatically. To quickly develop a protocol macro for serial devices, use Omron's CX-Protocol software. It contains typical commands to quickly create the short hand-shaking program and register it for later use in the PLC's memory.

■ Types of Protocol

Protocols	External devices	Required products
Standard system protocols	OMRON components	Serial Communications Module
User-created protocols	General-purpose external device	Serial Communications Module + CX-Protocol (Windows-based protocol support software)

■ Application Examples

Standard System Protocols

Perform data transfers with OMRON components using standard system protocols. There is no need to develop your own protocols in the example shown here.

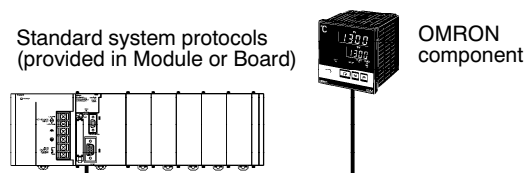

User-Created Protocols

To create data transfers with non-OMRON components, simply define parameters using the CX-Protocol Software.

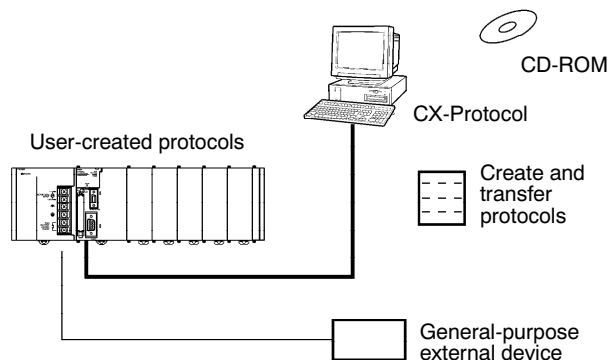

All the Hand-Shaking Commands for Many Omron Controllers with Serial Communications

The Two Main Functions of Protocol Macros

1. Creating Communications Frames

The communications frames can be easily created according to the specifications required by the connected device. Data from I/O memory in the CPU can be easily included as part of a communications frame to read from or write to I/O memory.

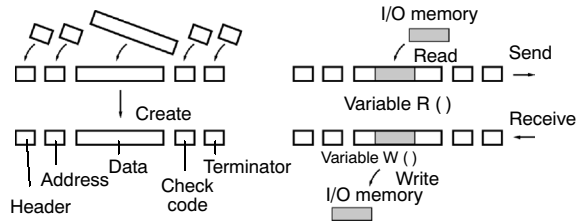

2. Creating Frame Send/Receive Procedures

The required processing, including sending and receiving communications frames, can be performed one step at a time based on the results of the previous step, and then CX-Protocol Software can be used to trace send and receive data.

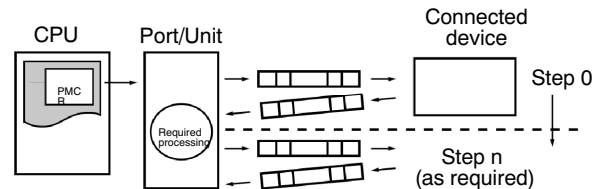

Standard System Protocols

Component	Model	Send/receive sequences
CompoWay/F-compatible components (Items below are: Digital Controllers and Temperature Controllers.)		
• Small Digital Controller with Communications (53 x 53 mm)	E5CK	Present value read, set point read, manipulated variable read, etc.
• Temperature Controllers with Digital Indications (96 x 96 mm or 48 x 96 mm)	E5□J-A2H0	Set point write, alarm write, PID parameter write, etc.
• Digital Controllers with Communications (96 x 96 mm)	ES100□	Uses CompoWay/F command send/response receive
• High-density Temperature Controller with communications (8 loops)	E5ZE	
Intelligent Signal Processors	K3MA-□	Display value read, comparison value read, write, etc.
Bar Code Readers	Laser Scanner type	V500
	CCD type	V520
Laser Micrometer	3Z4L	Measurement condition set, continuous measurement start, etc.
Machine Vision Systems	High speed, high precision, low cost	F200
	High-precision inspection/positioning	F300
	Character inspection software/positioning software	F350
ID Controllers	Electromagnetic coupling	V600
	Microwave	V620
Hayes Modem AT Command	—	Modem initialize, dial, send, etc.

Note: You will find Protocols for the F400 Vision System available to download from the Software Patches and Utilities area on Omron's website, www.omron.com/oei.

RS-232C to RS-422A Adapter Unit

Long-Distance Transmissions and No Separate Power Supply

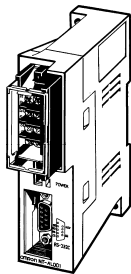

NT-AL001

The NT-AL001 is used to connect an Operator Interface Terminal or other device with an RS-232C terminal to a device with an RS-422A terminal.

■ Features

- Long-distance transmissions are possible through an RS-422A interface. By converting from RS-232C to RS-422A and then back to RS-232C, a transmission distance of up to 500 m can be achieved.
- No power supply is required. If the 5-V terminal (150 mA max.) is connected from the RS-232C device, a separate power supply is not required to drive the Adapter Unit.
- Duct wiring can be used. The removable terminal block enables wiring not possible with D-sub connectors. (The RS-232C interface is 9-pin D-sub.)

■ Communications Specifications

RS-232C Interface

Item	Specification
Baud rate	64 Kbps max.
Transmission distance	2 m max.
Connector	9-pin, D-sub connector (female)

RS-422A Interface

Item	Specification
Baud rate	64 Kbps max. (depends on RS-232C baud rate)
Transmission distance	500 m max.
Terminal block	8 terminals, M3.0; detachable

Provides Easy Interface between Omron PLCs and Temperature Controllers or Digital Panel Meters



CJ1W-CIF21

Data transmission between Omron Process and Temperature Controllers and Panel Meters is automatically handled via the DM area of the CPU. There is no need for communication commands to handle these CompoWay/F or SYSWAY communications.

Data read from the components is automatically stored in the designated area of the DM. Conversely, data from the designated area of the DM is automatically written to the components. This simplifies PLC changes in the set temperature (SP) and in monitoring the present value (PV) of Temperature Controllers and other components.

■ Features

- Interface with Omron Process and Temperature Controllers that implement either CompoWay/F or SYSWAY protocols (will support a combination of both types of components).
- Up to 18 units can be connected to one PLC
- Compatible with CS1, CJ1, CQM1H, and CPM2A PLCs.
- CIF21 unit is identical in size to CJ1 Series PLC Modules.

■ System Configuration

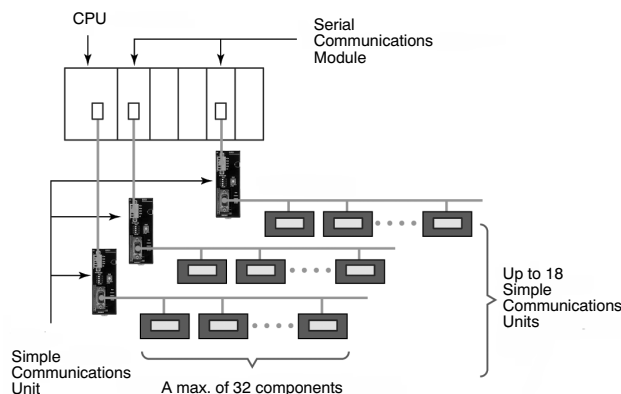

■ Specifications

Item	Description	
CJ1W-CIF21	Simple Communications Module	
Power supply	24 VDC (external power supply required)	
Allowable supply voltage	20.4 to 26.4 VDC (Recommend CPM2C-PA201)	
Current consumption	1.5 W	
RS-422/485 (upper port)	Function	Data can be sent to and received from Omron components via RS-422, RS-485 (terminal block) using SYSMAC or CompoWay/F protocol
	No. of connectable components	Up to 32
	Communication speeds with components	9.6 kbps, 19.2 kbps, 38.4 kbps, 57.6 kbps
RS-232C (lower port)	Function	The PLC and Host Link (SYSWAY) can be connected via RS-232C
	Applicable PLC models	CJ1 Series, CS1 Series, CQM1H Series, CPM2A Series
	PLC port	The RS-232C port, or the peripheral port of the CPU, or the RS232C port of the Serial Communication Board or Unit
	Communication speed with the PLC	9.6 kbps, 19.2 kbps, 38.4 kbps, 57.6 kbps
Weight	150 g max.	

Note: This product interfaces with the CJ1 only by RS-232C connection, not via the backplane.

■ Some of the Products Supported

- Temperature Controllers
- Modular Temperature Controller
- Digital Controller Board
- Digital Controllers (Standard Models)
- Digital Controllers (Valve Model)
- Digital Controllers (Programmable)
- Fuzzy Logic Temperature Controller
- Electronic Timer/Counter
- Digital Panel Meters
- Weighing Meter
- Frequency/Rate Meter
- Period Meter
- Up/Down Counting Meter
- Temperature Meter
- Linear Sensor Digital Panel Meter