

SJ100469  
(ON 0NIMARD) 台票理図

版数 REV.	年月日 DATE	DCN NO.	変更内容 DESCRIPTION	製図 DR.	担当 CHK.	査閲 APPD.	承認 APPD.
2	12.Apr.2004	054834	ADDED ITEMS etc.	M.YAMASHITA	T.KUDOU	—	Y. Ichiyama

TABLE 1

No. OF CONTACTS N	A	B	C
5	9.1	2.0	10.5
6	9.6	2.5	11.0
7	10.1	3.0	11.5
8	10.6	3.5	12.0
9	11.1	4.0	12.5
10	11.6	4.5	13.0
11	12.1	5.0	13.5
12	12.6	5.5	14.0
13	13.1	6.0	14.5
14	13.6	6.5	15.0
16	14.6	7.5	16.0
17	15.1	8.0	16.5
18	15.6	8.5	17.0
20	16.6	9.5	18.0
21	17.1	10.0	18.5
22	17.6	10.5	19.0
26	19.6	12.5	21.0
28	20.6	13.5	22.0
30	21.6	14.5	23.0
31	22.1	15.0	23.5
32	22.6	15.5	24.0
33	23.1	16.0	24.5
34	23.6	16.5	25.0
35	24.1	17.0	25.5
36	24.6	17.5	26.0
38	25.6	18.5	27.0
40	26.6	19.5	28.0
45	29.1	22.0	30.5
50	31.6	24.5	33.0

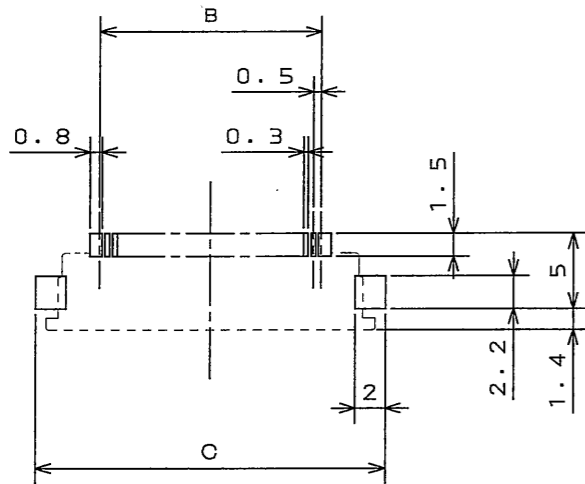
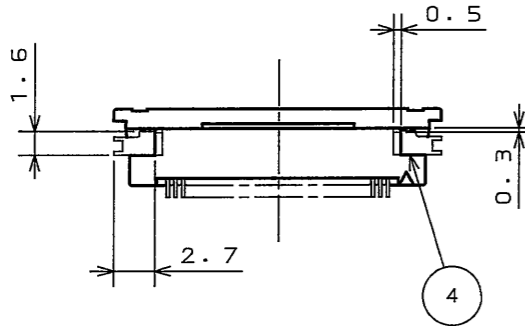
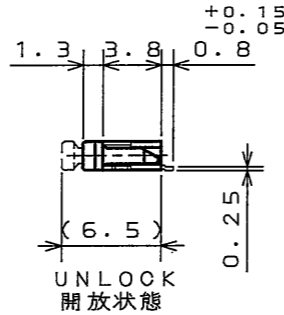
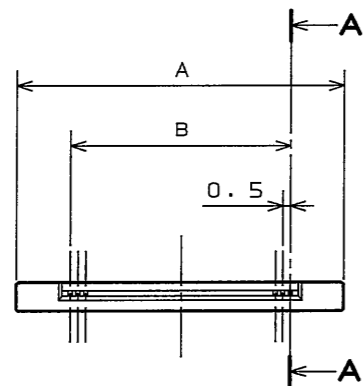
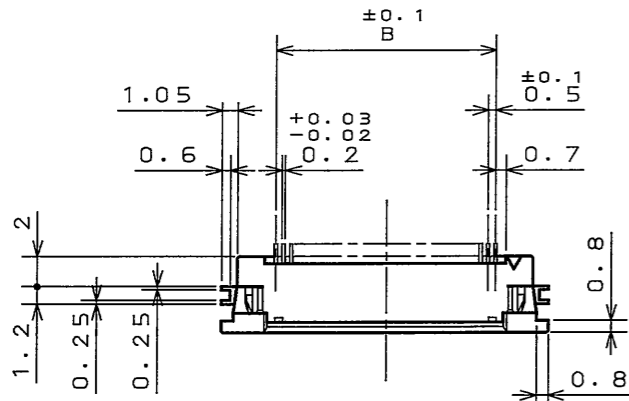

APPLICABLE P.C.B. DIMENSION (REF.)  
適合基板寸法 (参考)

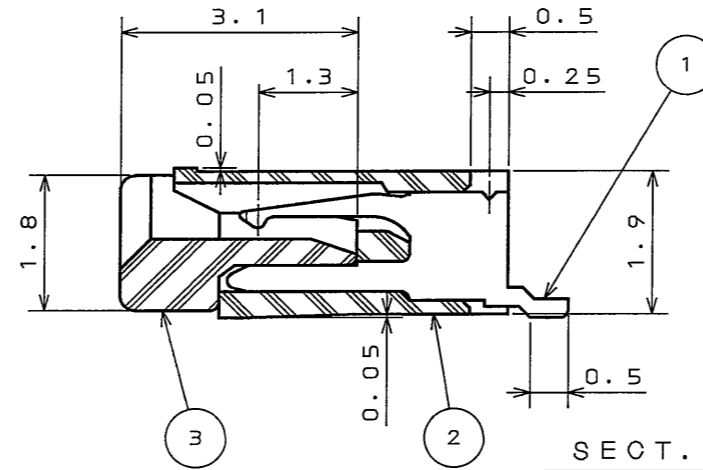

SECT. A-A  
(SCALE 10:1)

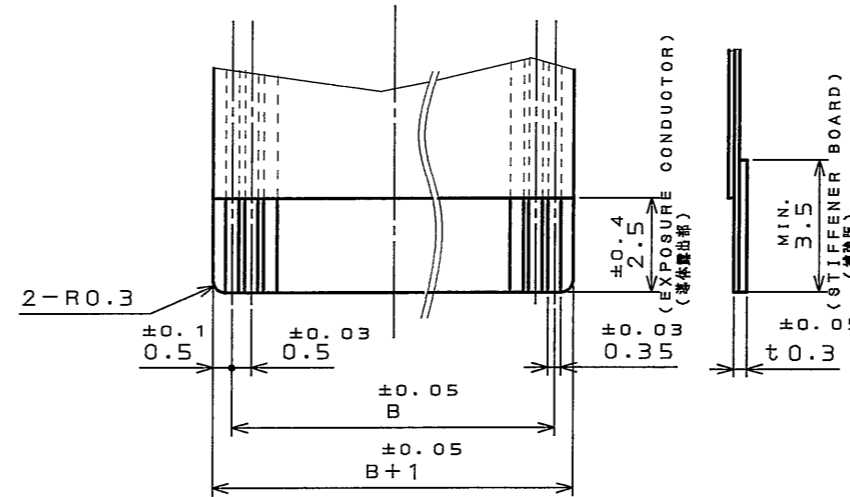

APPLICABLE F.P.C. DIMENSION (REF.)  
適合FPC寸法 (参考)

注1. F.P.Cの仕上げは金メッキのこと。  
NOTE1. EXPOSURE CONDUCTORS OF F.P.C SHOULD BE GIVEN GOLD PLATING.

符号 NO.	名称 DESCRIPTION	個数 QTY.	材料 MATERIAL	仕上 FINISH	備考 REMARKS
4	HOLD-DOWN	2	COPPER ALLOY	(LEAD-FREE) TIN/TIN ALLOY PLATING	
3	SLIDE INSULATOR	1	GLASS FILLED PPS		COLOR: WHITE UL94V-0
2	BASE INSULATOR	1	GLASS FILLED PPS		COLOR: BLACK UL94V-0
1	CONTACT	N	HIGH STRENGTH BRASS	SELECTIVE GOLD PLATING	

仕様書 (SPECIFICATION) JAOS-10135	第1版 (ORIGINAL DATE) 9.Jan.2004	尺度 (SCALE) 2:1	製図 DR. D.MACHIHARA	名称 (TITLE) IL-FPR-U**S -HF-N1	重量 (WEIGHT)
公差 (GENERAL TOLERANCE) 寸法 (DIMENSION) 角度 (ANGLES)	担当 CHK. T.KUDOU	製図 DR. D.MACHIHARA	製図 DR. D.MACHIHARA	製図 DR. D.MACHIHARA	製図 DR. D.MACHIHARA
. ±0.8 X° ± .X ±0.4 X°X' ± .XX ±0.1 .XXX ±	査閲 APPD. 承認 APPD. Y.ICHIYAMA	製図 DR. D.MACHIHARA	製図 DR. D.MACHIHARA	製図 DR. D.MACHIHARA	製図 DR. D.MACHIHARA

DOF-0-212E(03.08)



LEAD FREE この製品は鉛フリー品です

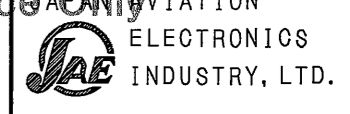

図面番号 (DRAWING NO.)  
SJ100469

版数 (REV.)  
2