

THIS DRAWING IS UNPUBLISHED. RELEASED FOR PUBLICATION, 19  
 © COPYRIGHT 19 BY AMP INCORPORATED. ALL INTERNATIONAL RIGHTS RESERVED.

LOC	DIST	P	F	REVISIONS				
				ZONE	LTR	DESCRIPTION	DATE	APPD
AF	50				D	REL PER 0710-0047-96	2/6/96	JR/JG

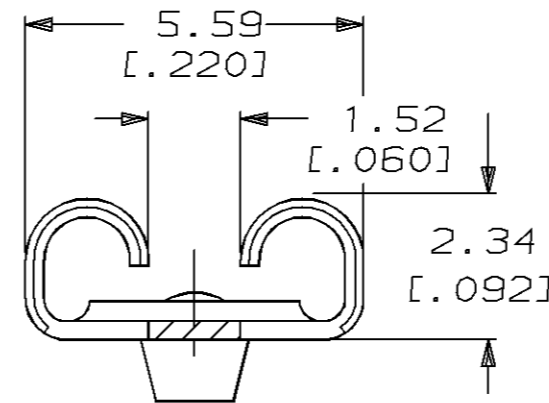
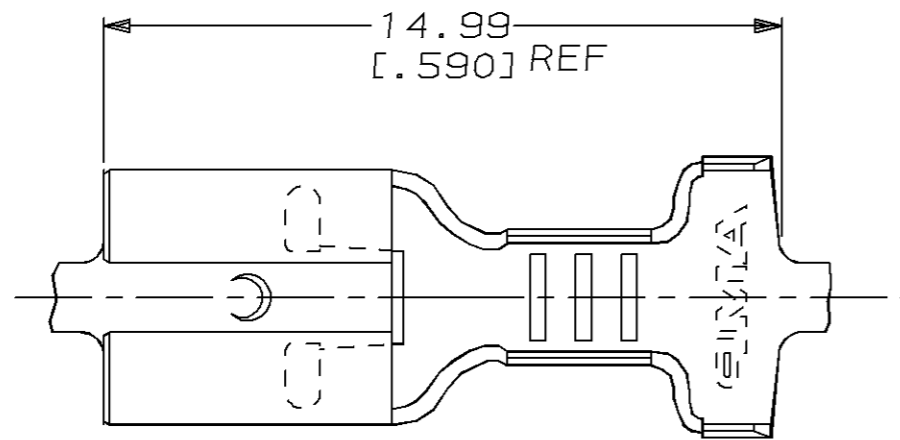

1 CONTINUOUS STRIP ON REELS

VIEW A-A  
SCALE 8:1

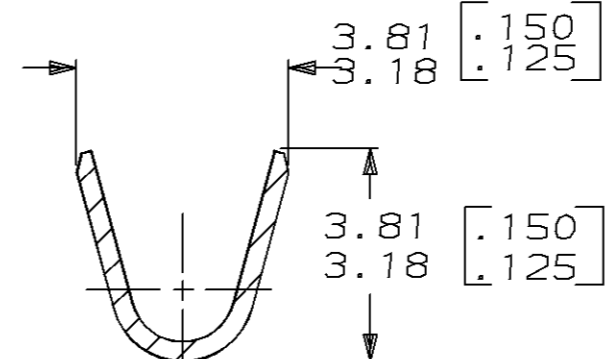

SECTION B-B  
SCALE 8:1

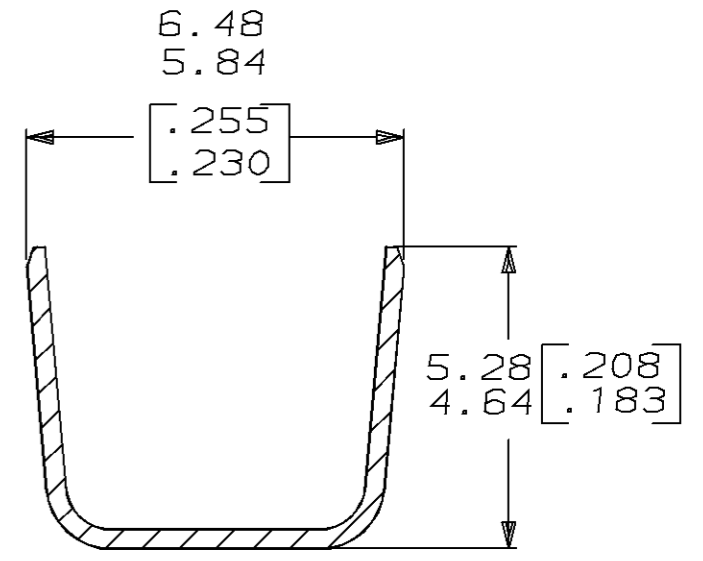

SECTION C-C  
SCALE 8:1

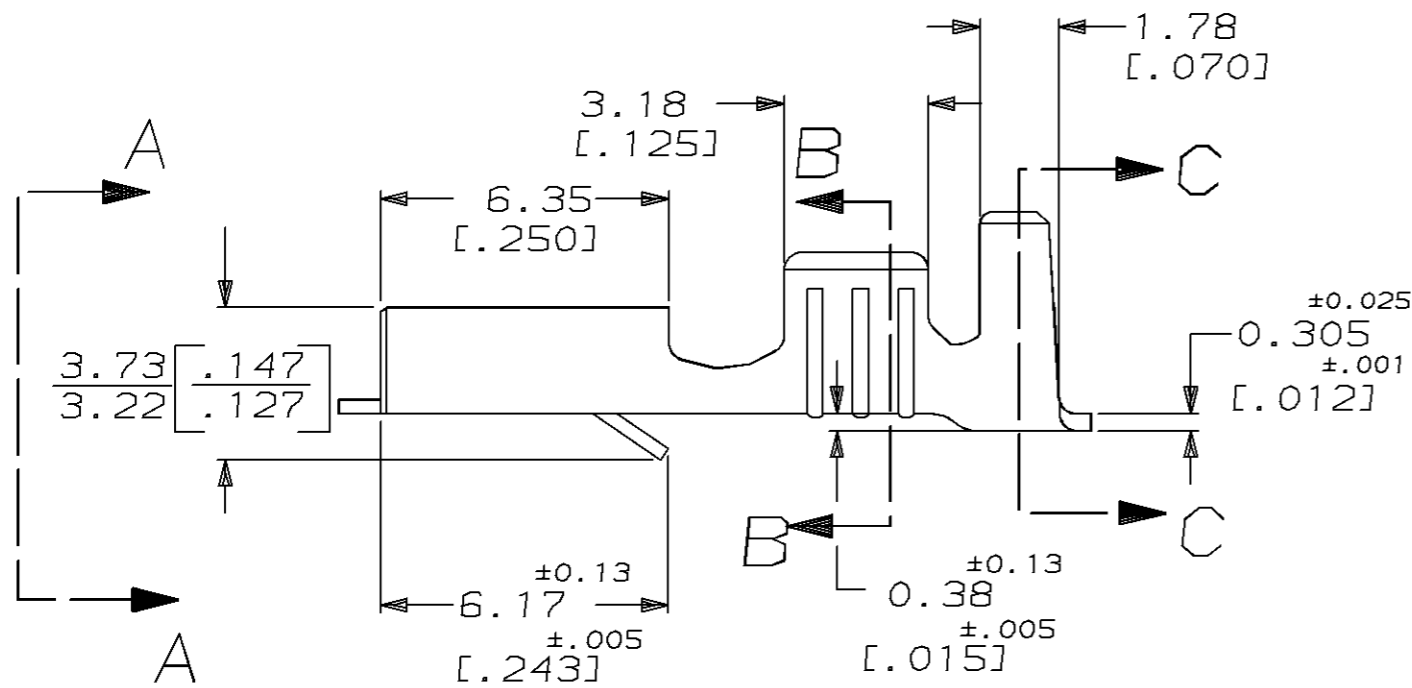

3.30-4.83 OR (2) 2.79 MAX [.130-.190 OR (2) .110 MAX]	[#18-#14] AWG OR (2) #18'S	0.813±0.025 [.032±.001]	63833-1
INSUL RANGE		WIRE SIZE	MATING TAB THICKNESS
DO NOT SCALE PRINT. UNLESS SPECIFIED DIMENSIONS IN mm [INCHES] TOLERANCES ON: 2 PLC DEC ± - 3 PLC DEC ± 0.25 [.010] ANGLES ± -		DR 3/3/95 JR RUTH CHK 3/3/95 MS FEHER APPD 3/3/95 J GILLESPIE APPD 3/3/95 R REINER PRODUCT SPEC -	<b>AMP</b> AMP INCORPORATED Harrisburg, Pa. 17105 NAME RECEPTACLE, FASTIN-FASTON,™ 4.75 [.187] SERIES
MATERIAL H04 BRASS		APPLICATION SPEC 114-2065 WEIGHT -	
FINISH -		SIZE <b>B</b>	CAGE CODE 00779
		DRAWING NO 63833	SHEET 1 OF 1
		SCALE 6:1	